

Shimadzu Journal

VOL.
04 **ISSUE 1**

New Energy and more...



Director's note

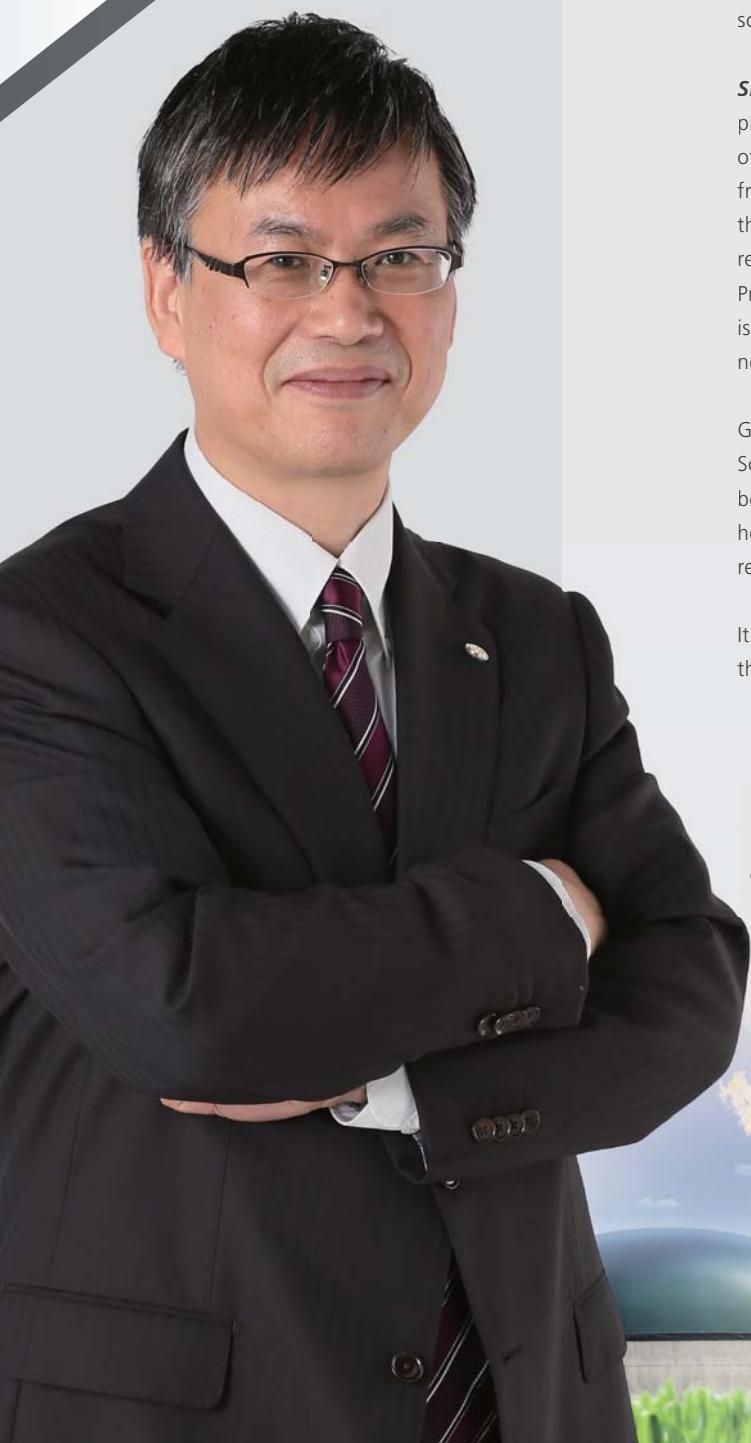

Dear Reader,

Welcome to the latest issue of **Shimadzu Journal**, focused on solutions for new energy. I am Shuzo Maruyama, General Manager of Analytical & Measuring Instruments Division, Shimadzu Corporation. I believe that only collaborative works with customers can advance new technologies and bring true solutions to the world. Last year, we established Innovation Centers in the U.S. and China to further promote collaborative research and development projects with leading academic and research institutions. We will be opening other innovation centers in Europe and Asia for the same purpose in the near future. Our goal is to diffuse the technologies acquired from each collaboration in the world and to contribute to the advancement of science and technology.

Shimadzu Journal has been highlighting various collaborative research projects in specific application fields. This issue focuses on new energy. One of the featured articles is about a collaboration with Professor Osamu Ishitani from Tokyo Institute of Technology, Japan, who is the leading researcher in the field of artificial photosynthesis. Another article discusses algal biomass research and hydrocarbon analysis, the data set of which was provided by Professor Keiichi Tomishige from Tohoku University, Japan. In addition, this issue contains information on other applicable topics, as well as the latest news and applications.

Guided by our corporate philosophy: "Contributing to Society through Science and Technology", we will strive to fulfill customers' wishes for a better society. Motivated by the depth of future opportunities, we earnestly hope to exceed customers' expectations and establish high-quality customer relationships.

It is our sincere desire that you and Shimadzu build a new era, and we hope that this journal will help you. We always welcome your feedback.

Yours Sincerely,

A handwritten signature in black ink, appearing to read 'Shuzo Maruyama', written in a cursive style.

Shuzo Maruyama

General Manager, Analytical & Measurement Instruments Division



CONTENTS

Featuring New Energy



Insight from Customer

Professor Osamu Ishitani of the Graduate School of Science and Engineering, Tokyo Institute of Technology, Japan 04

We interviewed Professor Osamu Ishitani of the Graduate School of Science and Engineering, Tokyo Institute of Technology (Tokyo, Japan). His research is focused mainly on artificial photosynthesis. He and Shimadzu started a collaborative relationship in 2012, which resulted in the QYM-01 photoreaction quantum yield evaluation system that permits accurate and simple quantitation measurements of absorbed photons.



New Energy

Cutting-Edge Development of Artificial Photosynthesis That Drives Reduction of Carbon Dioxide 07

To solve the three main problems of a shortage of energy resources, a shortage of raw materials for carbon compounds, and global warming, creation of an ideal artificial photosynthesis system using technology that uses solar energy to immobilize CO₂ as a resource is considered and discussed.

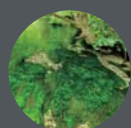

New Energy

Applications of GC-MS in Algal Biomass Research 11

Due to the growing awareness of global warming, algal biomass has received attention as a new renewable energy alternative to oil resources. This article introduces an example of the GC-MS measurement of squalane hydrogenation degradation products obtained by modifying squalene with a catalyst.



New Energy

Analysis of Hydrocarbons Using PCI-GC-MS 13

Interest in hydrocarbon-producing microalgae is growing in the field of renewable energy development. Research focused on obtaining petrochemical raw material from the hydrocarbons produced by microalgae is being conducted, and mass spectrometry is used in identification of these products.



Shimadzu Selection 15

These articles were selected by Shimadzu. Relating to new energy, they derive from application notes and technical reports, and feature a variety of instruments and cutting-edge technologies.



Natural Gas Analysis

Making Improvements to Today's Natural Gas Analysis Systems 17

In recent years, driven mainly by rising energy demand, many parts of the world have witnessed a resurgence in the production of petrochemicals. New technologies for mining the deep shale deposits for natural gas have been refined in the U.S. and made extraction of these deposits economically viable. We have the tools to build the systems that meet the demand of today's petrochemical industry. In this article, improved technologies in the NGA system will be introduced.



Topics

Shimadzu Establishes Innovation Centers in the U.S. and China to Promote Joint Research and Development 22

To further promote joint research and development projects with leading academic and research institutions, Shimadzu Corporation has established the SSI Innovation Center at its U.S. Subsidiary, Shimadzu Scientific Instruments, Inc. (SSI), Maryland, U.S. and the Shimadzu China Mass Spectrometry Center (hereinafter the China MS Center) at the Beijing Branch of its Chinese subsidiary, Shimadzu (China) Co., Ltd.



Topics

Shimadzu Teams with the University of Wisconsin-Milwaukee to Form Interdisciplinary Chemistry Lab 23

Shimadzu Scientific Instruments (SSI) announces the opening of the Shimadzu Laboratory for Advanced Applied and Analytical Chemistry at the University of Wisconsin-Milwaukee (UWM). The new 2,000-square-foot laboratory and office suite is a hub for research across the entire UWM campus, as well as a classroom for teaching the theory and practice of mass spectrometry.



Topics

Shimadzu Partners with Miyazaki Prefecture in Establishing an Incorporated Association to Analyze Food Safety 24

Shimadzu Corporation has established an incorporated association in partnership with Miyazaki Prefecture to analyze the safety of food. The association will undertake analyses of residual pesticides in agricultural and food products.



New Products

ICPMS-2030, EDX-7000/8000 (Energy Dispersive X-ray Fluorescence Spectrometers), GCMS-QP2020, GC/MS Off-Flavor Analyzer 25

Professor Osamu Ishitani of the Graduate School of Science and Engineering, Tokyo Institute of Technology, Japan

We interviewed Professor Osamu Ishitani of the Graduate School of Science and Engineering, Tokyo Institute of Technology (Tokyo, Japan). His research is focused mainly on artificial photosynthesis. He and Shimadzu started a collaborative relationship in 2012, which resulted in the QYM-01 photoreaction quantum yield evaluation system* that permits accurate and simple quantitation measurements of absorbed photons.

* The QYM-01 system is not available in Europe and may not be available in some other countries. Please contact your local Shimadzu representative for availability.

Dr. Ishitani, thank you very much for sparing time for this interview. First of all, could you explain the background to this collaborative research with Shimadzu? Why did you choose Shimadzu as your partner?

I have conducted research into the photochemistry of metal complexes, and in particular into the development of artificial photosynthesis systems, for many years, and in recent years the number of researchers participating in this field of research has increased drastically. However, it worries me that upon attending the presentations of these researchers, it is not uncommon that many of them will not calculate quantum yield, and will not pose their arguments based on quantum yield results.

While quantum yield is the most important and fundamental quantitative value for research into photoreactions, it is not simple, experimentally, for a researcher that is researching photochemistry to measure the quantum yield of a photoreaction. One of the first things taught to students in classes on photochemistry is the first law of photochemistry. Simply put, this law states that light absorbed by a molecule gives rise to a photoreaction. Consequently, a measurement of quantum yield requires not a calculation of the quantity of light emitted, but a calculation of the number of photons absorbed by a substrate. Calculating this number requires the preparation of various experimental conditions and execution of a complicated procedure. In our laboratory, we prepare hand-made equipment and have summarized the research procedure in manual form so that all students are able to, without fail, measure quantum yield. Nevertheless, I believe a fair number of students find this research difficult to conduct, despite these preparations. Also, our equipment and methods have not always been totally satisfactory. For example, the equipment we developed could be used to calculate the number of photons entering the reaction vessel, but calculating the number of photons that pass through the vessel has not been easy. Consequently, experiments had to be performed under the assumption that almost all incident light was absorbed by the solution inside the reaction vessel. Furthermore, when a light source is emitting light continuously for an extended period of time, the light source gradually degrades and the quantity of emitted light decreases. We were unable to estimate this change. We needed to work together with engineers skilled at systemization of equipment as well as experts in spectroscopy to make the improvements to our equipment required for resolution of these problems.

When approached by Shimadzu regarding the joint research into development of equipment for photoreactions, two areas of equipment development occurred to me that I thought could be realized. One was to enable people who conducted research into photochemical reactions but were not specialists in photochemistry to perform accurate yet simple measurements, and the other was to enable measurements of quantum yield with smaller errors than previously possible while under diverse experimental conditions.



Could you provide a summary of this research and tell us what discoveries and achievements have been made so far?

Basically, this research aims to enhance the functionality of, and improve the operability of equipment used in photoreactions, where the equipment in question is unique and was created by us. The three main topics of this research are as follows.

First is ease-of-operability of light quantity measurement and improvement of the precision. Two commonly used methods of measuring light quantity employ a chemical actinometer and a photoelectric transducer. Our equipment previously employed a method that used a chemical actinometer, but operation of this equipment was complex and required an experienced operator. This problem was resolved for us by Shimadzu. Second is measurement of the quantity of light transmitted through the reaction solution. Measuring the quantity of light transmitted through the reaction vessel requires an extremely complex procedure, a problem that was resolved by introducing a system that takes constant measurements of the quantity of illuminating light during the photoreaction. By utilizing this equipment, we can now change the substrate concentration (which affects the extent of absorbance by the reaction solution) at will and determine the quantum yield of the photoreaction. Third was the problem of canceling out error caused by degradation of the light source. This was resolved based on a proposal made by an engineer at Shimadzu. The mechanism devised introduces a beam splitter in front of the reaction vessel to take off part of the illuminating light, which is directed into another system that provides a constant measurement of the quantity of light. This allows us to perform measurements of quantum yield with good precision even during experiments using a light source for an extended period of time. A system that uses a photodiode detector to measure the absorption spectra of the solution was added to the light illumination system we developed, and placed at right angles to the illuminating light used for photoreactions. This system detects reaction intermediates that accumulate in solution during the actual photoreaction, and has been

found useful in tracing the degradation process of photocatalysts. This equipment was also integrated into Shimadzu's equipment. In this way, we can now use this equipment to perform accurate measurements of the quantum yield of photoreactions, while simultaneously tracing changes in the spectra of the reaction solution.

Why are you interested in artificial photosynthesis? What is the goal of your research?

My entry into this field was probably influenced by my experience of the 1973 oil crisis. The family business was as a wholesaler of cosmetic and sanitary products. When the first oil crisis hit, nearly all stocks of these products were sold out, and for days on end we had no products to sell. I can still remember the frantic atmosphere in the family shop at the time. I felt first-hand how a lack of oil would result in an extremely dangerous situation for humanity. After that, I studied industrial chemistry at Kobe University, where I found myself moving into research into artificial photosynthesis. I then moved away from Kobe University, which had no laboratories performing research into this field at the time, to become a postgraduate at the Graduate School of Engineering of Osaka University, which was a mecca for photochemistry research then and since. It is there I came under the tutelage of Chyongjin Pac (currently a professor at Korea University), a world authority in photochemistry, which was a very positive experience for me.

Since then, I have been pursuing research focusing on fundamental research into the chemistry required for conversion of light energy into chemical energy. I am particularly interested in the utilization of sunlight for recycling carbon dioxide. The overall objective is quite obvious: to utilize sunlight to convert carbon dioxide into a high-energy substance. A real-world practical application of this idea would provide a method of resolving in one blow the problems of energy, dwindling carbon-based energy sources, and of global warming, which are, problems faced by all humanity that are likely to become more grave as time goes on.

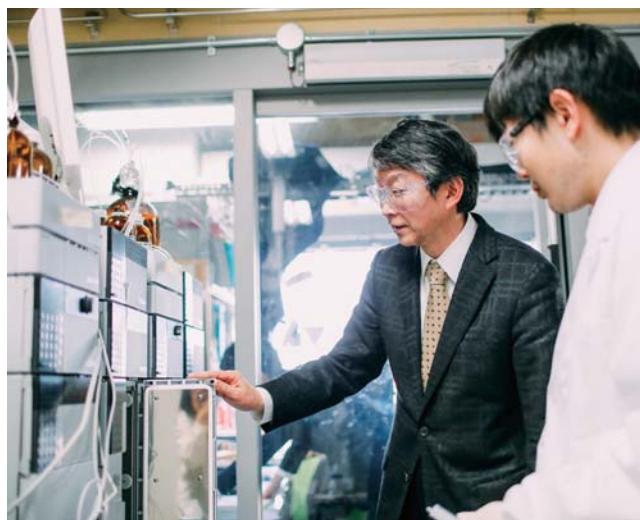

How are our instruments helping you?

It is essential to the advancement of photochemistry that the efficiency of photoreactions conducted by different research groups can be evaluated with high precision and without difficulty. I hope sincerely that Shimadzu instruments will be introduced in many other laboratories, allowing us to debate with them from the same standpoint. In that respect, I would like to see improvements made that reduce the price of these instruments so they can be introduced to all laboratories.

What are Shimadzu's strengths compared to other vendors (not limited to the instruments)?

Shimadzu's strength is its comprehensive reach. Even this project was realized thanks to the involvement of a Shimadzu specialist in spectroscopy and a Shimadzu engineer skilled at system design and system structure.

Finally, could you share any requests that you have with respect to analytical and measuring instrument vendors?

I am extremely grateful for the interest you have shown in the evaluation of photoreactions. Since research advances in parallel in all areas of the world, I would like you to make progress towards the launch of products on a worldwide scale.

It was significant to know what you think of us and our collaboration. We will strive to meet your request more than ever. Thank you very much.



Here are his recent publications:

1. H. Takeda, K. Ohashi, A. Sekine, O. Ishitani, Photocatalytic CO₂ Reduction Using Cu(I) Photosensitizers with a Fe(II) Catalyst, *J. Am. Chem. Soc.*, **2016** in press, DOI:10.1021/jacs.6b01970
2. R. Kuriki, H. Matsunaga, T. Nakashima, K. Wada, A. Yamakata, O. Ishitani, K. Maeda, A Nature-Inspired, Highly Durable CO₂ Reduction System Consisting of a Binuclear Ruthenium(II) Complex and an Organic Semiconductor Using Visible Light, *J. Am. Chem. Soc.*, **2016** in press, DOI:10.1021/jacs.6b01997
3. A. Nakada, T. Nakashima, K. Sekizawa, K. Maeda, O. Ishitani, Visible-light-driven CO₂ reduction on a hybrid photocatalyst consisting of a Ru(II) binuclear complex and a Ag-loaded TaON in aqueous solutions. *Chemical Science* **2016** in press, DOI: 10.1039/C6SC00586A.
4. G. Sahara, R. Abe, M. Higashi, T. Morikawa, K. Maeda, K. Ueda, O. Ishitani, Photoelectrochemical CO₂ reduction using a Ru(II)-Re(I) multinuclear metal complex on a p-type semiconducting NiO electrode *Chem. Commun.*, **2015**, accepted (DOI: 10.1039/C5CC02403J)
5. Y. Yamazaki, T. Morimoto, O. Ishitani, Synthesis of Novel Photofunctional Multinuclear Complexes Using a Coupling Reaction *Dalton Trans.* **2015**, accepted (DOI: 10.1039/C5DT01717C)
6. G. Sahara, O. Ishitani, Efficient Photocatalysts for CO₂ reduction *Inorg. Chem.* **2015**, 54, 5096-5104. (DOI: 10.1021/ic502675a)
7. E. Kato, H. Takeda, K. Koike, K. Ohkubo, O. Ishitani, Ru(II)-Re(I) Binuclear Photocatalysts Connected by -CH₂XCH₂- (X = O, S, CH₂) for CO₂ Reduction *Chem. Sci.* **2015**, 6, 3003-3012, OnlineOpen (DOI: 10.1039/C4SC03710C)
8. A. Nakada, K. Koike, T. Nakashima, T. Morimoto, O. Ishitani, Photocatalytic CO₂ Reduction to Formic Acid using a Ru(II)-Re(I) Supramolecular Complex in an Aqueous Solution *Inorg. Chem.* **2015**, 54, 1800-1807. (DOI: 10.1021/ic502707t)
9. K. Maeda, G. Sahara, M. Eguchi, O. Ishitani, Hybrids of a Ruthenium(II) Polypyridyl Complex and a Metal Oxide Nanosheet for Dye-Sensitized Hydrogen Evolution with Visible Light: Effects of the Energy Structure on Photocatalytic Activity *ACS Catal.* **2015**, 5, 1700-1707. (DOI: 10.1021/acscatal.5b00040)
10. Y. Ueda, H. Takeda, T. Yui, K. Koike, Y. Goto, S. Inagaki, O. Ishitani, A Visible-Light Harvesting System for Efficient CO₂ Reduction Using a Supramolecular Ru(II)-Re(I) Photocatalyst Adsorbed in Periodic Mesoporous Organosilica *ChemSusChem.* **2015**, 8, 439-442. OnlineOpen (DOI: 10.1002/cssc.201403194)

Cutting-Edge Development of Artificial Photosynthesis That Drives Reduction of Carbon Dioxide

Osamu Ishitani, PhD, Graduate School of Science and Engineering, Tokyo Institute of Technology

Significance of Researching Artificial Photosynthesis

The nuclear accident at the Fukushima Daiichi nuclear power station following the Great East Japan Earthquake has shaken the core of Japan's energy policy. Furthermore, increasing our dependence on fossil resources will only lead to accelerating the depletion of available fossil resources, which is also the most important raw material for the chemical industry. We cannot ignore the fact that, even now, over 20% of petroleum is consumed as a raw material for chemicals (Fig. 1). In other words, a depletion of our fossil resources will directly lead to a shortage in carbon resources.

Furthermore, the increasing concentration of CO₂ in the atmosphere has become a major cause of global warming. In response to global pressures to significantly reduce CO₂ emissions, Japan is actively involved in proposing countermeasures, but still has not found a fundamental solution.

Nevertheless, it is clear that the three main problems casting a dark shadow on the future of mankind, namely a shortage of energy resources, a shortage of raw materials for carbon compounds, and global warming, are all inevitably caused by the energy and chemical industries being totally dependent on fossil-based resources. Therefore, solutions for inhibiting CO₂ emissions, and developing new energy systems and new carbon sources must be proposed in a complementary manner.

As shown in Fig. 2, plant photosynthesis creates a carbon cycle that contributes to long-term stability of the Earth's atmospheric elements. However, humans have used large quantities of the fossil resources, formed from the accumulation of organic matter underground, as raw materials for chemicals and fuels. Most of the fossil resources used by humans are eventually burned, which has resulted in discharging CO₂ into the atmosphere so fast that it is dramatically changing its concentration in the atmosphere. Furthermore, we currently have no methods available for immobilizing the CO₂ and reusing it as a resource.

If it were possible to use CO₂ as a reservoir for solar energy and build a system that efficiently generates products that could be used as a carbon source, then all three of these grave problems could be solved at the same time. Consequently, it would be desirable to build a man-made system that essentially serves the same function as photosynthesis in green plants, which converts light energy into chemical energy. In environments unsuitable for growing plants, creating an artificial photosynthesis system using technology that uses solar energy to immobilize CO₂ as a resource would provide an ideal solution for the depletion of fossil-based resources and global warming.

Functions Required for Artificial Photosynthesis

Photosynthesis in plants involves a system combining complicated organs that is too difficult to recreate artificially. Therefore, a technique of isolating the essential functions and then developing a system able to perform those functions has been used. Fig. 3 shows a diagram that summarizes the functions necessary for artificial photosynthesis. The important functions are summarized as follows:

1. Capture light with high efficiency: Due to the low photon flux of sunlight, if a molecular photocatalyst is used, then a system to efficiently capture and intensify the light (light-harvesting antenna) is required.
2. To use visible light, which has relatively low energy, to drive chemical reactions that require high energy, a Z-scheme electron transport system must be used. In other words, a system that absorbs two photons successively and causes electron transfer is required.
3. An oxidative catalyst that captures four electrons from two water molecules is required.
4. A catalyst that causes efficient multi-electron reduction of carbon dioxide is required.

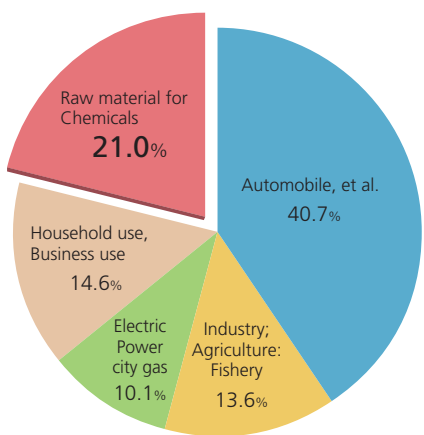

Fig. 1 Petroleum Classification by Intended Usage: Prepared from Japanese Oil Federation Data, Oil Industry Today, 2009

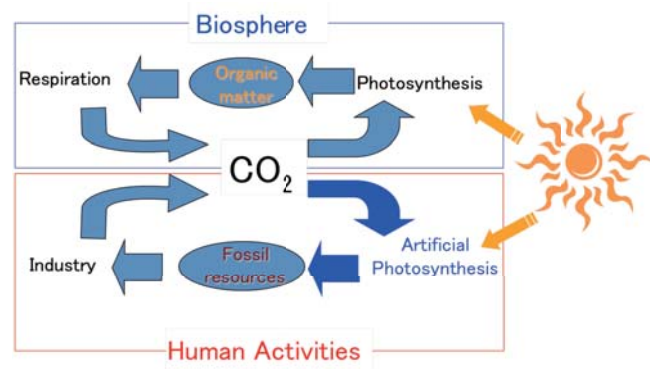

Fig. 2 Photosynthesis and Artificial Photosynthesis

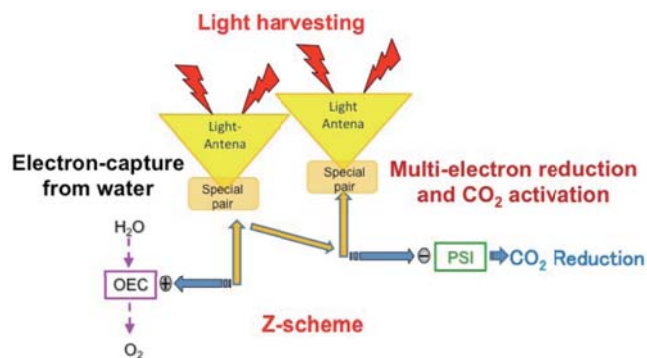

Fig. 3 Functions Required for Artificial Photosynthesis

CO₂ is the most oxidized form of carbon compound, so reduction is important for its activation. In the photoelectron-transfer reaction, which is an important step in artificial photosynthesis, absorption of one photon, in principle, drives transfer of only one electron. However, reducing CO₂ by one electron is not practical because it requires a high electric potential of -1.9 V vs. NHE and it also generates unstable CO₂^{•-} compounds. Therefore, there have been attempts to build photochemical multi-electron reduction systems. For example, the two-electron reduction of CO₂ can be used to form industrially useful CO and formic acid. The equilibrium potential of that reaction is about 1.3 V lower than one-electron reduction. Consequently, achieving practical photoreduction of CO₂ requires a system for causing multi-electron reduction.

One-electron reduction species of metal complexes, generated in an excited state achieved when a metal complex absorbs light, or by photoreaction in the presence of a reducing agent, have a strong reducibility. For example, in the typical case of a redox photosensitizer [Ru(bpy)₃]²⁺ (bpy = 2,2'-bipyridine) used to drive the electron transfer by photoexcitation, the electric potential of one-electron oxidation at the ground state is $E_{1/2} = 1.53$ V vs. NHE, but -0.59 V if photoexcited. Therefore, obtaining excitation energy significantly increases its reducing power. In addition to this redox photosensitizer for driving photoelectron transfer, immobilization of CO₂ by photoreduction also requires a catalyst that enables the multi-electron reduction of CO₂.

Photocatalytic Function of Re(I) Complex

J.M. Lehn et al. reported that CO was catalytically generated when a DMF/TEOA (5:1 v/v) solution containing *fac*-Re(bpy)-(CO)₃Cl (**Re-Cl**) was exposed to light in a CO₂ atmosphere⁽¹⁾. With a CO quantum yield of 0.14, it was the most efficient CO₂ reduction photocatalyst at the time. Furthermore, this photocatalyst system had the characteristic of generating only minimal hydrogen or formic acid, even in the presence of water. The photocatalytic activity of the rhenium complex *fac*-[Re(bpy)(CO)₃X]ⁿ⁺ is highly dependent on the type of monodentate ligand X⁽²⁾. For example, if the monodentate ligand X is an SCN⁻ (**Re-SCN**) complex, then the photocatalyst has an extremely efficient CO₂ photoreduction quantum yield of 0.3. However, if X is Cl⁻ (**Re-Cl**), then the photocatalyst efficiency is about half as much, as described above, and if X is CN⁻ (**Re-CN**), then it shows no catalytic activity at all. Almost all CO₂ photoreduction catalyst systems involve two coexisting species (a photosensitizer plus catalyst). In contrast, the rhenium complex is a unique photocatalyst that functions as both a photosensitizer and catalyst. Consequently, it has attracted considerable attention and generated many research projects (Fig. 4). The first step of the photocatalytic reaction has been clearly identified

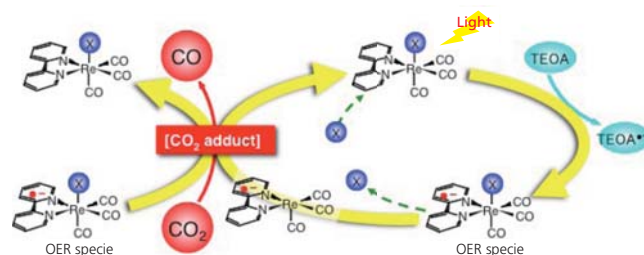

Fig. 4 Reaction Mechanism of Photocatalytic Reduction of Carbon Dioxide

by laser spectroscopy⁽³⁾. In other words, the excited state of the MLCT triplet from the rhenium complex generated by light absorption quenches the electron transfer by the reducing agent, so that the one-electron reduced (OER) specie of the rhenium complex [Re(bpy*)(CO)3X]⁻ is generated. Then the monodentate ligand X⁻ desorbs from that OER specie and is replaced by a CO₂ ligand. In the case of **Re-CN**, the OER specie is relatively stable, so that no desorption of CN⁻ occurs at all, which is what caused it to show no photocatalytic activity. As mentioned above, reducing CO₂ to CO requires two electrons, where the second electron is supplied by the OER specie from another molecule. After desorption of the CO, the photocatalyst is regenerated by the monodentate ligand X⁻, that was released into the solution, reattaching to the complex (Fig. 2). **Re-SCN** showed relatively high photocatalytic activity because both desorption and reattachment of the SCN⁻ ligand from/to the OER specie occur efficiently. In the case of **Re-Cl**, on the other hand, the efficiency of the Cl⁻ ligand reattachment is low, which resulted in a lower photocatalytic efficiency⁽²⁾.

Elucidating the photocatalytic reaction mechanism in detail often provides very valuable information for improving the photocatalyst function. These results provided the following indicators necessary for increasing the efficiency of the CO₂ reduction reaction using a rhenium complex photocatalyst.

- (1) The reducing agent must be able to reduce the excited photocatalyst and generate an OER specie with high efficiency.
- (2) The ligand must desorb from the OER specie and react with CO₂ very quickly. An OER specie from another molecule must be able to reduce the generated CO₂ adduct quickly.
- (3) After the CO is generated, the original complex must be regenerated highly efficiently by reattaching the desorbed ligand to the center of the rhenium.

Based on the above photocatalyst design indicators, we have been developing a photocatalyst system that reduces CO₂ with high efficiency. Several successful examples are described below.

Photocatalyst System Combining Two Re(I) Species

To satisfy condition (2) indicated above, the OER specie must be unstable. However, the OER specie must be stable enough to satisfy condition (3). Therefore, to solve this apparent contradiction, we proposed a photocatalyst system that separates the two functions of the OER specie, specifically by mixing two rhenium complexes. The

OER specie of $fac-[Re(bpy)(CO)_3(MeCN)]^+$ desorbs monodentate ligands readily. In contrast, the OER specie of $fac-[Re(4,4'-(MeO)_2bpy)(CO)_3 - \{P(OEt)_3\}]^+$ is stable and has a strong reducing power due to the electron-releasing methoxy group attached to the 4,4' position of the bpy ligand. Using a reaction system with a mixture of these complexes at a mole ratio of 1:24 achieved a quantum yield of 0.59 for the CO_2 reduction (Φ_{CO}) photocatalyst⁽²⁾. To further strengthen the system's function, we developed a system using a ring-shaped Re(I) polynuclear complex as the photosensitizer, which shows strong absorption of visible light and offers high quantum yield for OER specie generation. This resulted in a Φ_{CO} of 0.81, which is the highest efficiency for a photocatalyst system reported thus far⁽⁴⁾.

Ru(II)-Re(I) Supramolecular Complex Photocatalyst

Using a tris(diimine)ruthenium(II) complex with strong absorption in the visible region as a photosensitizer and linking it to an Re(I) complex catalyst by means of a bridging ligand, we developed a highly efficient CO_2 reduction photocatalyst driven by visible light⁽⁵⁾. In particular, when a Ru(II)-Re(I) binuclear complex linked by two alkyl chains was exposed to visible light in the presence of a sacrificial reducing agent BIH, it efficiently and nearly selectively generated CO (according to the equation below)⁽⁵⁾. This resulted in very good photocatalytic properties, with a quantum yield of CO generated by irradiation of visible light of 59 %, over 3000 CO molecules (TN) generated per photocatalyst molecule, and over 35 catalytic turnovers per minute (TF).

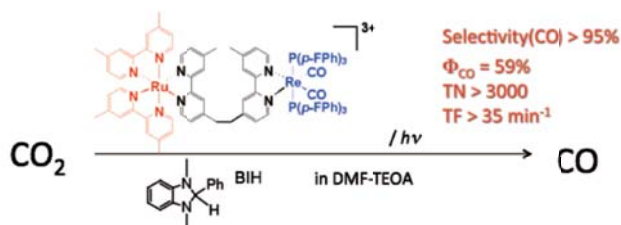

This type of polynuclear complex used to serve multiple functions with a single molecule is referred to as a supramolecular photocatalyst.

Supramolecular photocatalysts with the Re(I) catalyst portion swapped with a Ru(II) carbonyl complex are able to selectively reduce CO_2 to formic acid with high efficiency and high endurance⁽⁶⁾.

Metal Complex - Semiconductor Composite Photocatalysts

We succeeded in developing an artificial Z-scheme composite photocatalyst that combines a supramolecular photocatalyst with a semiconductor catalyst (Fig. 5)⁽⁷⁾. On the surface of a TaON semiconductor substrate supporting silver microparticles, the Ru(II)-Ru(II) supramolecular photocatalyst was secured to methylphosphonate groups introduced as anchors. When the semiconductor catalyst and the supramolecular complex photocatalyst photosensitizer successively absorbed visible light, reduction of CO_2 to formic acid at the catalyst portion of the supramolecular catalyst and oxidation of methanol on the TaON substrate occurred simultaneously.

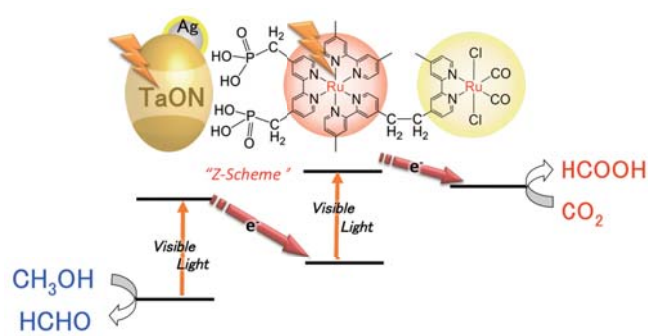
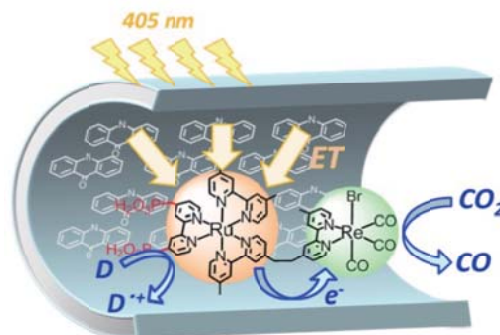

Fig. 5 Hybrid Semiconductor Photocatalyst

Photocatalyst with a Light Capturing Function

Periodic mesoporous silica (PMO) is a group of substances with a highly ordered mesoporous structure with pores on the order of a few nm in diameter. They exhibit unique optical functions depending on the skeleton organic groups that form the mesopore walls. **Acd-PMO** (Fig. 1), which contains the acridone group (**Acd**), has been reported to absorb visible light and efficiently transfer its excitation energy to organic pigments immobilized inside the mesopores⁽⁹⁾. Therefore, we decided to perform a detailed study of the CO_2 reduction function of a new composite material produced by introducing a Ru(II)-Re(I) supramolecular photocatalyst into the **Acd-PMO** mesopores⁽¹⁰⁾. We synthesized a polynuclear Ru(II)-Re(I) complex with phosphonate groups ($-PO_3H_2$) attached to ligand terminals as anchors (**RuRe**, Fig. 1). When the substance was added to acetonitrile, together with **Acd-PMO** and stirred, a composite material was formed with **RuRe** immobilized in the **Acd-PMO** mesopores. Then using the 400 nm excitation light, which is the primary wavelength absorbed by the **Acd-PMO** material, the light emission characteristics of the composite were studied in detail. The result indicated that introducing **RuRe** efficiently quenched light emission from the **Acd** group and a new light emission was observed from the Ru photosensitizer. This result shows that excitation energy from the photoexcited **Acd** group was transferred to the Ru photosensitizer.

This composite was suspended in a DMF-triethanolamine solution containing benzimidazole derivatives (BIH) as a reducing agent. When it was exposed to 405 nm monochromatic light in a CO_2 atmosphere, the CO_2 was efficiently reduced to selectively generate CO. This achieved 590 CO turnovers during 36 hours of light exposure (using the introduced **RuRe** as a reference). Compared to a composite material (**RuRe/MCM41**) created by introducing **RuRe** to mesoporous silica (MCM41) that does not absorb 405 nm light or have other light-capturing functions, using the **RuRe/Acd-PMO** composite generated about 2.4 times more CO. These results clearly show that the light-capturing effect of **Acd-PMO** can enhance photocatalyst properties by efficiently collecting light in **RuRe**.



References

- (1) J. Hawecker, J.-M. Lehn, R. Ziessel, Photochemical and electrochemical reduction of carbon dioxide to carbon monoxide mediated by (2,2'-bipyridine) tricarbonylchlororhenium(I) and related complexes as homogeneous catalysts *Helv. Chim. Acta*, 69 (1986) 1990.
- (2) H. Takeda, K. Koike, H. Inoue, O. Ishitani, Development of an efficient photocatalytic system for CO₂ reduction using rhenium(I) complexes based on mechanistic studies, *J. Am. Chem. Soc.*, 130 (2008) 2023-2031.
- (3) C. Kotal, A.J. Corbin, G. Ferraudi, Further studies of the photoinduced reduction of carbon dioxide mediated by tricarbonyl-bromo(2,2'-bipyridine)ruthenium(I), *Organometallics*, 6 (1987) 553.
- (4) T. Morimoto, C. Nishiura, M. Tanaka, J. Rohacova, Y. Nakagawa, Y. Funada, K. Koike, Y. Yamamoto, S. Shishido, T. Kojima, T. Saeki, T. Ozeki, O. Ishitani, Ring-Shaped Re(I) Multinuclear Complexes with Unique Photofunctional Properties, *J. Am. Chem. Soc.*, 135 (2013) 13266-13269.
- (5) Y. Tamaki, K. Koike, T. Morimoto, O. Ishitani, Substantial improvement in the efficiency and durability of a photocatalyst for carbon dioxide reduction using a benzimidazole derivative as an electron donor, *J. Catal.*, 304 (2013) 22-28.
- (6) Y. Tamaki, T. Morimoto, K. Koike, O. Ishitani, Photocatalytic CO₂ reduction with high turnover frequency and selectivity of formic acid formation using Ru(II) multinuclear complexes, *Proc. Natl. Acad. Sci. USA*, 109 (2012) 15673-15678.
- (7) K. Sekizawa, K. Maeda, K. Domen, K. Koike, O. Ishitani, Artificial Z-Scheme Constructed with a Supramolecular Metal Complex and Semiconductor for the Photocatalytic Reduction of CO₂, *J. Am. Chem. Soc.*, 135 (2013) 4596-4599.
- (8) T. Yui, A. Kan, C. Saitoh, K. Koike, T. Ibusuki, O. Ishitani, Photochemical Reduction of CO₂ Using TiO₂: Effects of Organic Adsorbates on TiO₂ and Deposition of Pd onto TiO₂, *ACS Appl. Mater. Interfaces*, 3 (2011) 2594-2600.
- (9) H. Takeda, Y. Goto, Y. Maegawa, T. Ohsuna, T. Tani, K. Matsumoto, T. Shimada, S. Inagaki, Visible-light-harvesting periodic mesoporous organosilica, *Chem. Commun.*, (2009) 6032-6034.
- (10) Y. Ueda, H. Takeda, T. Yui, K. Koike, Y. Goto, S. Inagaki, O. Ishitani, A Visible-Light Harvesting System for CO₂ Reduction Using a Ru(II)-Rel Photocatalyst Adsorbed in Mesoporous Organosilica, *ChemSusChem*, 8 (2015) 439-442.

Applications of GC-MS in Algal Biomass Research

Yoshiyuki Okamura, Shimadzu Corporation

Due to the growing awareness of global warming, algal biomass has received attention as a new renewable energy alternative to oil resources. Algal production efficiency per unit area is higher than for corn and sugarcane. In addition, CO₂ and organic drainage are used during algal cultivation, so benefits are also anticipated in terms of air and water purification. Moreover, policies have been raised in the U.S. and Europe that specify an increase in jet fuel bio ratios; as a result, increases in the demand for biofuel equivalents to jet fuel are anticipated. At present, there are issues with the high cost of algal biofuel production in comparison to crude oil. However, the algal biofuel market is expected to grow to the scale of 800 billion yen by 2020 in Japan (JETRO, 2013). Squalene (C₃₀H₅₀) is one of the oils obtained from algae. Since it is a hydrocarbon equivalent to heavy oil, it must be modified for use as a jet fuel.

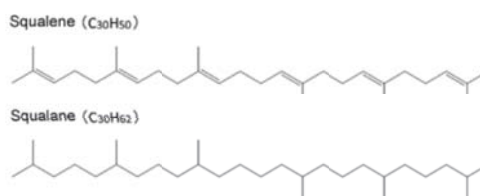

Fig. 1 Molecule Structures of Squalene and Squalane

This article introduces an example of the GC-MS measurement of squalane hydrogenation degradation products obtained by modifying squalene with a catalyst.

Squalane (C₃₀H₆₂) is a saturated hydrocarbon with a branched structure, obtained by hydrogenating squalene (Fig. 1). As shown in Fig. 2, hydrogenation degradation products are generated by cleaving C-C bonds in the squalene molecule using a catalyst.

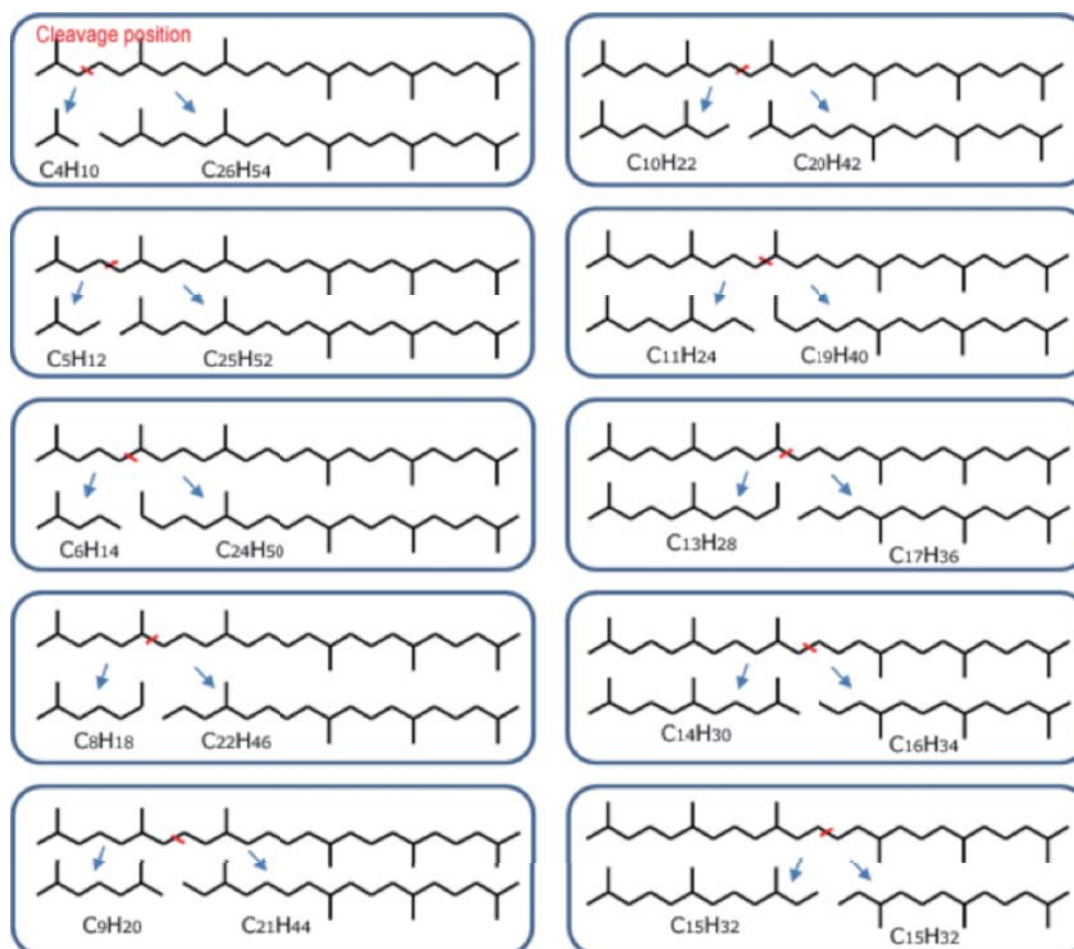

Fig. 2 Hydrogenation degradation products are generated by cleaving C-C bonds in the squalane molecule using a catalyst

In the TIC chromatogram for the squalene hydrogenation degradation products (Fig. 3), it is evident that degradation products have been generated by the catalyst, since hydrocarbon peaks C_{12} to C_{29} can be observed in addition to the peak for the main component, squalane (C_{30}). The intensities of peaks C_{12} , C_{18} , C_{23} , and C_{28} , which are shown in red circles, are less than for the other peaks, so it is believed that they are hard to generate in this catalytic reaction process. This means that an intermediate position between branches in the squalane molecule is selectively cleaved due to the action of this catalyst to generate degradation products retaining a branched structure.

It is possible to calculate the carbon number for these degradation products based on the molecular weight calculated using the chemical ionization (CI) method. For details on this analysis, refer to "Analysis of Hydrocarbons Using PCI-GC-MS (from next page, reproduction of Application News M270)". The samples in this investigation were kindly provided by Professor Tomishige of Hydrocarbon Chemistry, Resources and Environment Labs, Department of Applied Chemistry, Tohoku University.

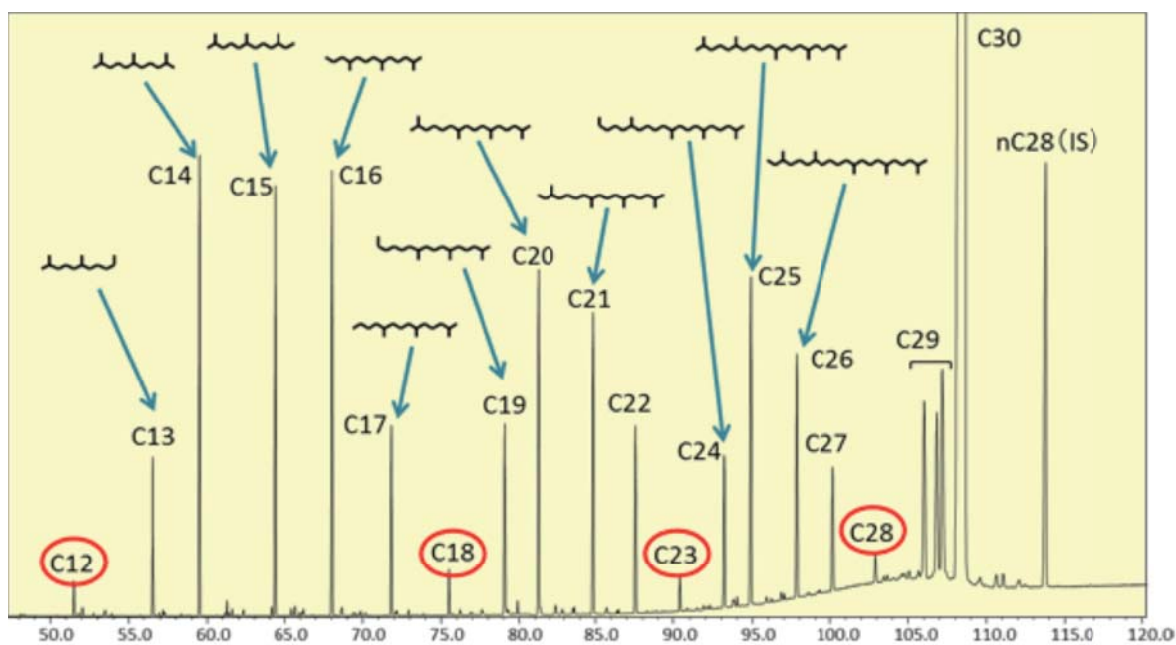
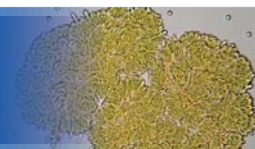

Fig. 3 TIC Chromatogram for Squalene Hydrogenation Degradation Products

Analysis of Hydrocarbons Using PCI-GC-MS



Kyoko Yamada, Shimadzu Techno-research Inc., Jun Nagata, Shimadzu Corporation

Interest in hydrocarbon-producing microalgae is growing in the field of renewable energy development. Since the hydrocarbons produced by microalgae contain no oxygen and are similar in properties to heavy oil, they can be a convenient substitution for existing liquid fuels, and it is advantageous that an energy resource do not compete with food production. Research is being performed into obtaining petrochemical raw material from the hydrocarbons produced by microalgae, and mass spectrometry is used in identification of these products. Gas chromatography-mass spectrometry (GC-MS) normally uses electron ionization (EI) to produce ions for analysis, but when using this EI method for hydrocarbon analysis, the larger the carbon number the more difficult it becomes to confirm the molecular ions on a mass spectrum. The ion-molecule reactions that occur with positive chemical ionization (PCI), however, tend to produce protonated molecules and dehydride molecules, from which information about molecular mass is easier to obtain compared to the EI method. In this article, we describe a case example of using PCI-GC-MS to measure hydrocarbons obtained from the catalytic decomposition of squalane, a compound obtained from microalgae.

Sample

Squalane was decomposed using a catalyst, the products of decomposition were diluted in mesitylene solvent, and this sample was analyzed using GC-MS.

The sample was provided by Prof. Keiichi Tomishige, Department of Applied Chemistry, Graduate School of Engineering, Tohoku University.

Analytical Conditions

Analysis was performed using both the EI method and the PCI method of ionization. For analysis by the PCI method, a specialized PCI ion source was used with methane as the reagent gas. For both the PCI method and the EI method, process conditions were optimized automatically by autotuning before performing analysis. Analytical conditions are shown in detail in Table 1.

Table 1 Analytical Conditions

Shimadzu Gas Chromatograph Mass Spectrometer	: GCMS-QP2010 Ultra
GC	
Column	: Rtx®-1 PONA (Shimadzu GLC Ltd.: P/N 314-100) 100 m × 0.25 mm I.D., 0.5 μm
Carrier Gas	: He
Control Mode	: Linear Velocity (21.2 cm/sec)
Injection Mode	: Split
Split Ratio	: 26.8
Oven Temperature	: 40 °C (10 min) → 3 °C/min → 300 °C (45 min)
Sample Injection Volume	: 1.0 μL (2.0 μL for the PCI method)
MS (EI Method)	
Ion Source Temperature	: 200 °C
Interface Temperature	: 300 °C
Tuning Mode	: High concentration
Measurement Mode	: Scan (<i>m/z</i> 10 to 500)
Event Time	: 0.3 sec
Ionization Voltage	: 70 V
MS (PCI Method)	
Reagent Gas	: Methane
Ion Source Temperature	: 170 °C
Interface Temperature	: 300 °C
Tuning Mode	: Standard
Measurement Mode	: Scan (<i>m/z</i> 45 to 500)
Event Time	: 0.3 sec
Ionization Voltage	: 70 V

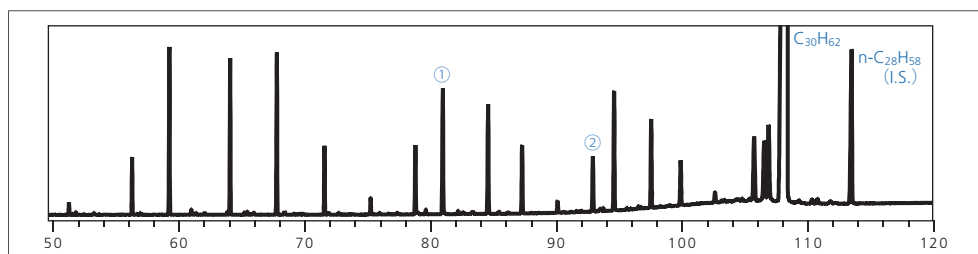

Fig. 1 Total Ion Current Chromatogram (EI)

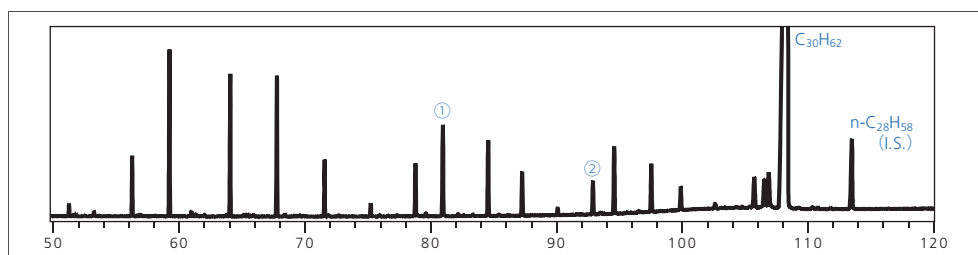

Fig. 2 Total Ion Current Chromatogram (PCI)

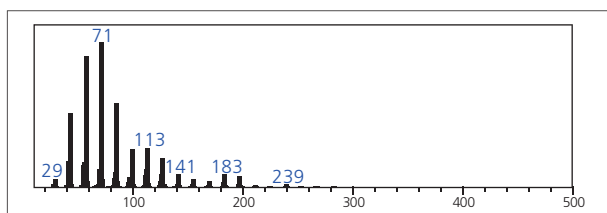

Fig. 3 Mass Spectrum (peak (1), EI)

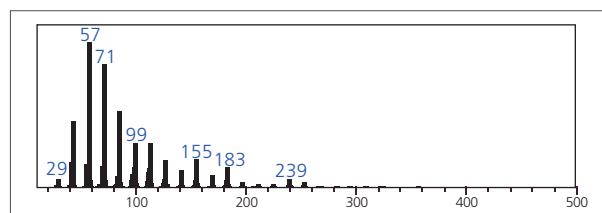

Fig. 5 Mass Spectrum (peak (2), EI)

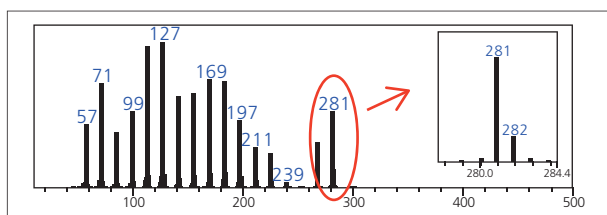

Fig. 4 Mass Spectrum (peak (1), PCI)

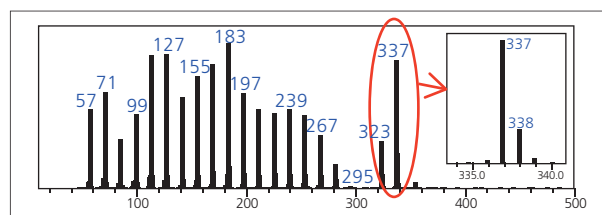

Fig. 6 Mass Spectrum (peak (2), PCI)

Results

Total ion current chromatograms (TICC) by the EI method and the PCI method are shown in Fig. 1 and 2, respectively. Mass spectra of peaks (1) and (2) (fractions corrected for hydrogen containing compounds) are shown in Fig. 3 to 6. The peak at 108 on the chromatograms is squalane ($C_{30}H_{62}$). Determining the maximum m/z on the EI mass spectra is difficult (Fig. 3 and 5), while peaks at m/z 281 and 337 can be observed on the PCI mass spectra (Fig. 4 and 6). Analyzing hydrocarbons using the PCI method also normally results in dehydride molecules. Assuming 282 and 338 were molecular masses, we checked the difference to the second largest m/z and found there was difference of 15 in both cases (cleavage of a methyl group), showing the results were appropriate. Finally, the carbon number was estimated based on the ratio of the maximum m/z and the peaks plus one (282/281 and 338/337) and the isotopic ratio of carbon, where peak (1) was assumed to be $C_{20}H_{42}$ (molecular mass: 282) and peak (2) was assumed to be $C_{24}H_{50}$ (molecular mass: 338).

Conclusion

We were able to obtain information on the molecular mass of hydrocarbons using PCI-GC-MS. PCI analysis was made easy using the GCMS-QP2010 Ultra due to the use of a special PCI ion source and process condition optimization by autotuning.

References

S. Oya, D. Kanno, H. Watanabe, M. Tamura, Y. Nakagawa, K. Tomishige Catalytic Production of Branched Small Alkanes from Biohydrocarbons, Article first published online: 11 JUN 2015, DOI: 10. 1002/cssc. 201500375

Posters from Recent Conferences

These articles were selected by Shimadzu. Relating to new energy, they derive from application notes and technical reports. They feature a variety of instruments and cutting-edge technologies. Please obtain the articles of your interest through the links on the titles.



Selection 1 Artificial Photosynthesis

QYM-01 Photoreaction Quantum Yield Evaluation System

The QYM-01 photoreaction quantum yield evaluation system permits accurate and easy quantitation measurements of absorbed photons when excitation light is irradiated onto a sample. The QYM-01 is the ideal system for in situ measurement of photochemical reactions and internal quantum yield evaluation of homogeneous photocatalysts.



Selection 2 Artificial Photosynthesis

High-Sensitivity Analysis of Formic Acid Using GC-BID in Artificial Photosynthesis Research

Artificial photosynthesis refers to a technique of creating high-energy materials using photocatalysis and solar energy, and is expected to play a role in the development of next-generation renewable energy. This Application News introduces an example in which the GC-BID is used for analysis of formic acid in an actual sample consisting of the solvent N,N-dimethylacetamide, used in the research of artificial photosynthesis.



Selection 3 Biomass

Analysis of Biomass Using Organic Acid Analysis System

Industrial production of bioethanol from biomass resources involves a process in which cellulose and hemicellulose in the biomass are decomposed using diastatic enzymes to be converted to monosaccharides such as glucose or xylose, which are then converted to ethanol by the action of yeast. Here, we introduce an example of the simultaneous analysis of acetic acid, formic acid, furfural, and 5-hydroxymethyl furfural, typically present in the biomass, using a combination of an organic acid analysis system together with an ultraviolet-visible spectrophotometric detector.



Selection 4 Biomass

Analysis of Organic Acids in Culture Medium Using Post-Column pH Buffering Organic Acid Analysis System

The shift from an emphasis on fossil fuels in recent years has been emphasized with increasingly active research into the bioproduction and manufacture of new energy sources and chemical products. Here, we introduce an example of analysis of organic acids in a culture medium using post-column pH buffered electrical conductivity detection in combination with a dual column oven, a system that provides both improved separation and high-selectivity detection.



Selection 5 Biomass

Simple Quantitative Measurement of Nannochloropsis Micro Algae in Water Using Shimadzu UV Micro Algae Analysis System

In studying micro algae, measurement of the daily growth (concentration) is important. Currently, this measurement is conducted by the dry weight method, in which the sample is filtered using filter paper, and then dried prior to weighing. Here, we introduce Shimadzu's newly developed UV micro algae analysis system which permits simple measurement of the micro algae concentration using a spectrophotometer.



Selection 6 Biomass

Monitoring of Algae Growth by TOC Measurement

This presents an example of a unique application in which the TOC-LCPH total organic carbon analyzer is used to track the growth process of microalgae by directly measuring, without conducting any pretreatment, the TOC content in a suspended culture of microalgae cells.

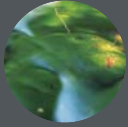

Selection 7 Biomass

Characterization of Algae by TOC Measurement

Microalgae can be used for the production of oil without competing with food production, and to a greater extent than other biofuels, its productivity per unit time and area is high, while arable land selection possibilities are great. Here, we introduce an example of a unique application in which the TOC-LCPH total organic carbon analyzer is used to characterize microalgae by directly measuring, without conducting any pretreatment, the TOC content in a suspended culture of microalgae cells.



Selection 8 Biomass

Measurement of TOC and TN in Marine Water Algae Culture Solution

The culturing of microalgae in various types of non-edible biomass has received considerable attention in recent years. Here, we introduce an example of the simultaneous measurement of TOC and TN in seawater using the TOC and TN measurement system consisting of the TOC-LCPH total organic carbon analyzer for microalgal biomass measurement and the TNM-L unit for total nitrogen measurement.



Selection 9 Energy

Tracera (GC-BID) Solution

The Tracera GC System utilizes Barrier Discharge Ionization Detector technology coupled with a GC-2010 Plus capillary gas chromatograph to create a GC system that makes it possible to reveal trace components that are difficult to see by other GC detectors. Shown here are 12 examples of applications using Tracera in a variety of fields such as artificial photosynthesis, coal-based chemical synthesis, etc.



Selection 10 Fuel Cell

Trace Impurity Analysis of Hydrogen Fuel in Fuel Cell Vehicle-Related Fields

With the development of fuel cell technology for electricity generation using hydrogen as fuel, attention is turning to household fuel cell systems and fuel cell vehicles. Here we introduce an example of high-sensitivity analysis of carbon monoxide in hydrogen and simultaneous analysis of impurities in hydrogen using the Tracera high-sensitivity gas chromatograph equipped with a BID detector.



Selection 11 Fuel Cell

X-Ray CT Observation of Fuel Cell MEA

Fuel cells are devices that convert the energy obtained from an electrochemical reaction of hydrogen fuel directly into electrical energy. Because they are highly efficient and emit only water, fuel cells have attracted great interest due to their potential for contributing significantly to providing a solution for both energy and environmental concerns. This Application News bulletin provides an example of using an X-ray CT system for fuel cell observation.



Selection 12 Lithium-ion battery

X-Ray CT Observation of Lithium-Ion Battery Electrodes

Today, rechargeable lithium-ion batteries are widely used in a variety of fields and are available in a wide range of shapes, capacities, and applications. X-ray CT systems are able to non-destructively observe the internal structure of items, and can therefore be used to analyze defective batteries, evaluate changes in the internal structure of batteries during cycle testing, etc. This application demonstrates how the inspeXio SMX-100CT can be used for detailed observation of the electrode structure in rechargeable lithium-ion batteries.



Selection 13 Solar Cell

Measurement of Transmittance of Solar Battery Glass -Measurement of Transmittance of a Light Scattering Solid Sample-

When measuring a solid sample with strong light scattering properties, using a 60 mm diameter integrating sphere can result in a change in photometric values at wavelengths where the detector is changed. We introduce an example measurement of the transmittance of solar battery glass that is strongly light scattering, where the change in photometric values is prone to occur.



Selection 14 Chemiluminescence

Measuring Peroxyoxalate Chemiluminescence Using a Spectrofluorophotometer

Chemiluminescence based on using oxalate esters features high-emission efficiency and long emission time and provides illumination for long periods without any electricity. Consequently, it is used for recreational, fishing, and many other applications where it is commonly called glow sticks. The following describes the luminescent process of peroxyoxalate chemiluminescence and gives an example of using an RF-6000 spectrofluorophotometer to measure the emission spectra of glow sticks.

Making Improvements to Today's Natural Gas Analysis Systems



Hiroyuki Aikawa, Ryosuke Kamae, Yuki Hashi, PhD, Shimadzu (China) Co., Ltd.

1. Introduction

In recent years, driven mainly by rising energy demand, many regions of the world have witnessed a resurgence in the production of petrochemicals. New technologies for mining the deep shale deposits for natural gas have been refined in the U.S. and made extraction of these deposits economically viable. In China, new technologies for turning coal into olefins by way of methanol (CTO: Methanol to Olefin) has fueled its economy and provided feedstocks for the chemical and polymer industries.

In every petrochemical process, measurement and quality control are essential. Processing plants must characterize the incoming raw materials. Finished products must be evaluated to ensure specifications are met. Every time natural gas changes hands, an analysis is done to determine its energy content and thus its value. There is a need for scientific instrument manufacturers to match the innovation shown by the petrochemical industry by producing high-precision, accurate equipment that this industry can rely on. Shimadzu Corporation is ready to meet this challenge with a lineup of NGA systems (Natural gas analyzers).

Our NGA system can include permanent gases such as H_2 , N_2 and light hydrocarbons from C_1 to C_6^+ . Samples may take the form of a gas or high-pressure liquid state. Our systems can combine standard analyses with extended analysis of condensates. We have the tools to build the systems that meet the demand of today's petrochemical industry. In this article, improved technologies in these NGA systems will be introduced.

2. Typical Natural Gas Analyzers (NGA)

2-1. Requirements of typical NGA Systems

Natural gas processing occurs in a number of steps. It begins with the extraction of the raw gas at the well head. Analyses occur at this stage to determine the water content, hydrogen sulfide and aromatic hydrocarbon content. These parameters are important in determining the best processing options and are closely monitored by the EPA if there is a flare associated with the well. From the source, the gas is transported to the processing plant by truck, train or pipeline, where again it is analyzed to determine its chemical composition. Finally, as the processing plant sells the finished, dry, sulfur-free natural gas to the distributor or end user, another analysis is done to determine the price based on the energy content of that particular lot. This is done by taking the percent composition of that lot of gas and calculating its BTU content. For each of these steps, Shimadzu offers a variety of NGA systems to comply with industry-standard methods such as those developed by ASTM, GPA, ISO and UOP. In many cases, multiple methods can be combined in a single GC to save on bench space and optimize a lab's budget.

2-2. Shimadzu NGA system

Table 1 shows two typical Shimadzu NGA systems. While "GC-2014NGA1" is a packed columns-based system and all components are detected by two TCDs, "GC-2014FNGA1" is a PLOT columns-based system (except for H_2 , H_2 detection) and all components are detected by two TCDs and one FID.

"GC-2014FNGA1" is called a Fast NGA system since the analysis time is only 10 minutes, enabling high productivity. The detection range of components with this system is shown in Table 2. This system consists of four sample loops and eight columns. O_2 , N_2 , CH_4 and CO are separated by an Rt-MS-5A plot column (0.53 mmI.D., 50 μm , 30 m) and CO_2 , C_2H_6 and H_2S are separated by an Rt-Q plot column (0.53 mmI.D., 20 μm , 30 m). These components are detected by TCD1. In order to avoid an overlapping of eluted peaks from two columns, the Rt-Q plot column analysis is started after the Rt-MS-5A plot column analysis has finished. This is referred to as a "Delay injection technique". C_3 or higher hydrocarbons are separated by the Rtx-1 column (0.32 mmI.D., 3.0 μm , 30 m) and detected by FID. C_6^+ components are back-flushed as a single peak. H_2 and He are separated by an MS-13X packed column (60/80 mesh, 2.1 mmI.D., 1.0 m) and detected by TCD2. (Fig. 2, 3)

One of the outstanding characteristics of this system is its short analysis time. This results from adapting a 0.32 mmI.D. capillary column for C_3 or higher hydrocarbons separation. Furthermore, a split line is placed in front of the capillary column in order to maintain good peak shape.



Fig. 1 NGA System based on GC-2014

Table 1 NGA system configuration, target compounds and analysis time

Model Name	GC-2014NGA1	GC-2014FNGA1
Standard Method	ASTM-D1945	ASTM-D1945
	ASTM-D3588	ASTM-D3588
	GPA-2261	GPA-2261
Flow Controller	Dual AFC	Dual AFC
	AUX-APC	AUX-APC
Valve Numbers	3	4
Column Numbers	6	8
Type of Detector	Dual TCD	Dual TCD, FID
Target Compounds	He, H ₂ , O ₂ , N ₂ , CH ₄ , CO, CO ₂ , C ₂ -C ₅ , H ₂ S, C ₆ ⁺	He, H ₂ , O ₂ , N ₂ , CH ₄ , CO, CO ₂ , C ₂ -C ₅ , H ₂ S, C ₆ ⁺
Analysis Time	17 min	10 min

Table 2 Detection range of components of the Fast NGA system

No.	Name of Compound	Concentration Range		Detector
		Low Conc.	High Conc.	
1	He	0.01%	10.0%	TCD-2
2	H ₂	0.01%	10.0%	TCD-2
3	O ₂	0.01%	20.0%	TCD-1
4	N ₂	0.01%	50.0%	TCD-1
5	CO	0.01%	5.0%	TCD-1
6	CO ₂	0.01%	20.0%	TCD-1
7	C ₂ H ₆	0.01%	10.0%	TCD-1
8	H ₂ S	0.10%	30.0%	TCD-1
9	CH ₄	20.0%	100.0%	TCD-1
10	C ₃ H ₈	0.001%	10.0%	FID
11	i-C ₄ H ₁₀	0.001%	10.0%	FID
12	n-C ₄ H ₁₀	0.001%	10.0%	FID
13	i-C ₅ H ₁₂	0.001%	2.0%	FID
14	n-C ₅ H ₁₂	0.001%	2.0%	FID
15	C ₆ ⁺	0.001%	0.5%	FID

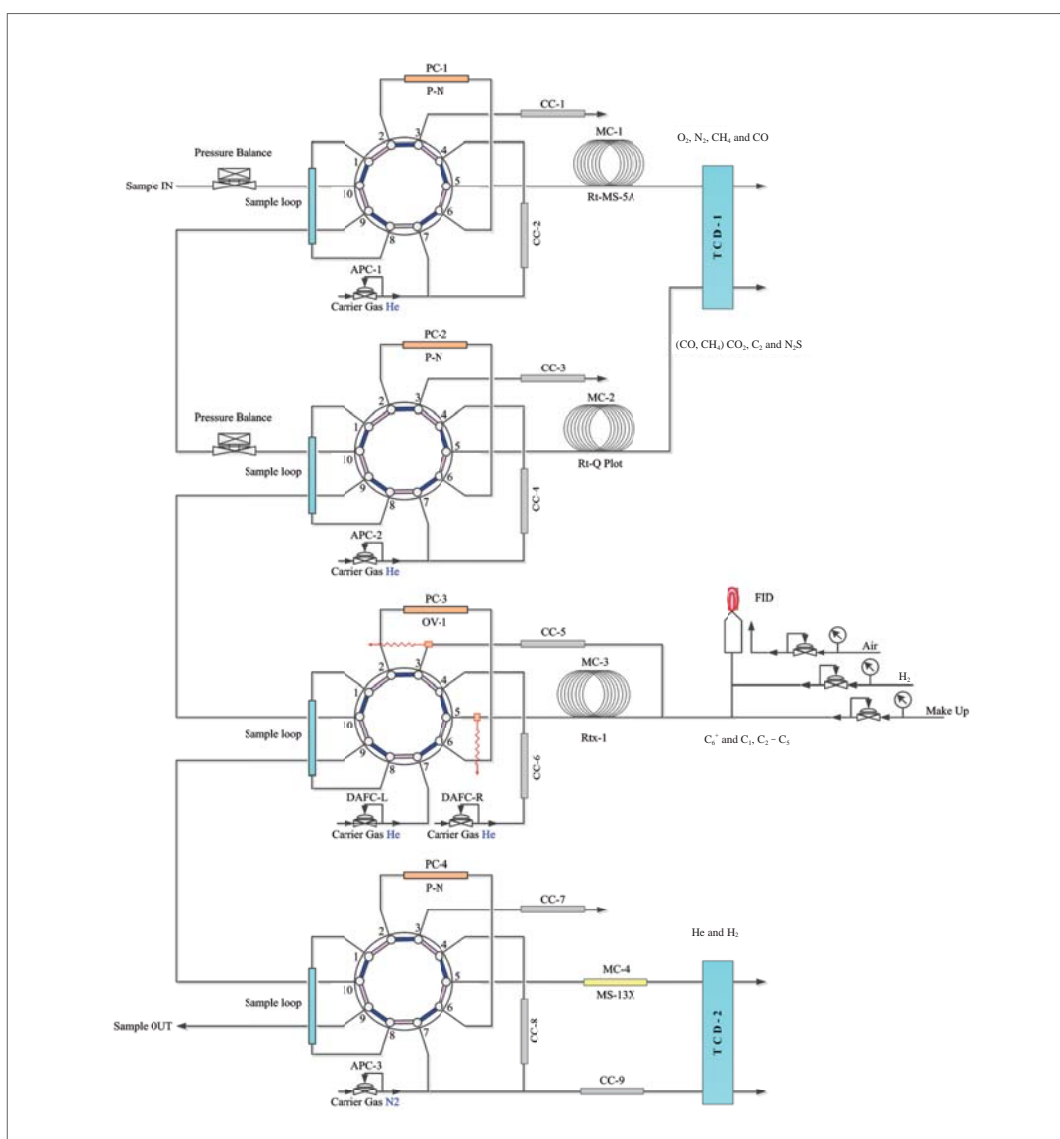

Fig. 2 Flow diagram of the Fast NGA system

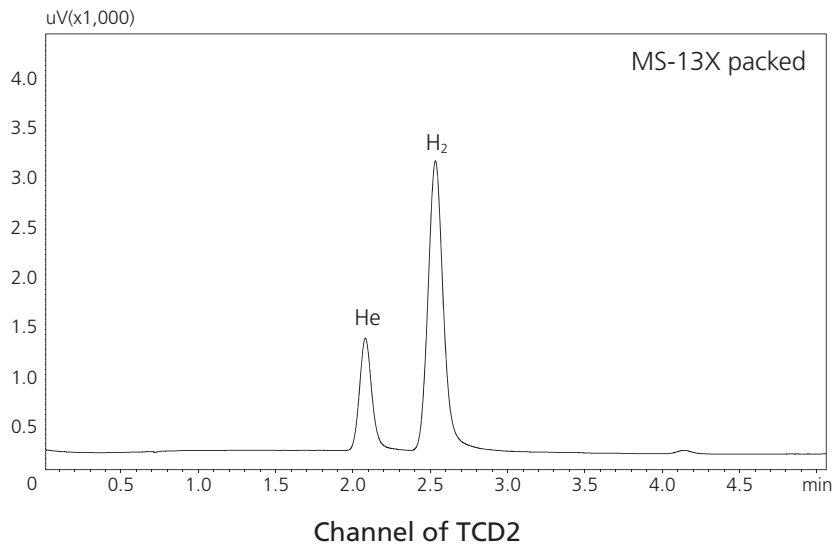
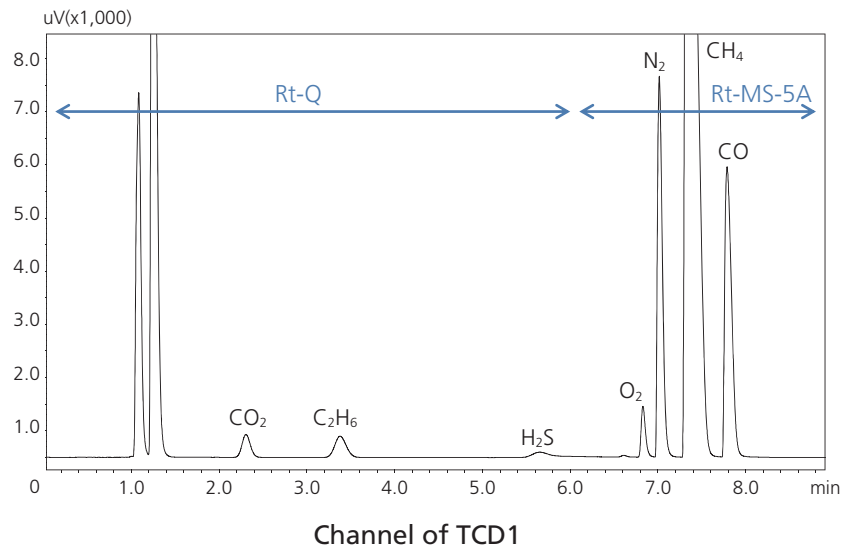
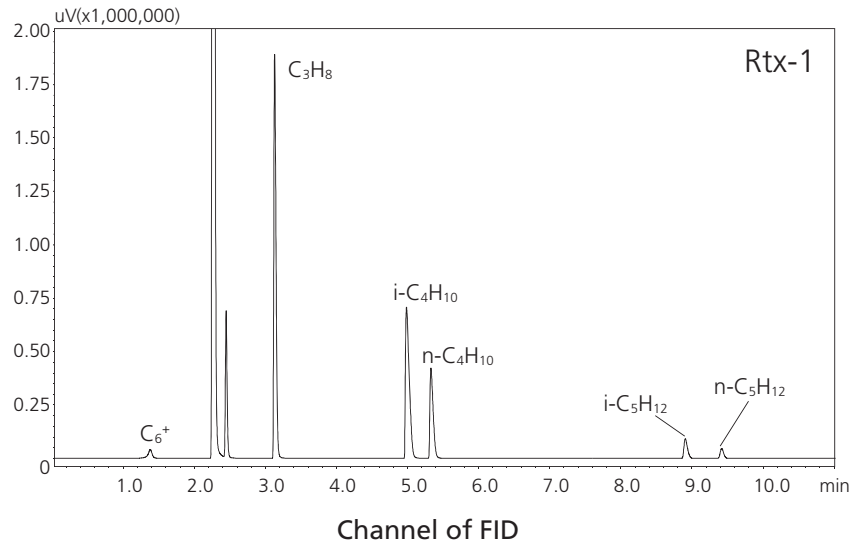

Fig. 3 Chromatogram of the Fast NGA system

3. NGA System using the Barrier Discharge Ionization Detector (BID)

3-1. The barrier discharge ionization detector (BID)

The BID is a highly sensitive detector that creates ionization from dielectric barrier discharge plasma. It offers highly sensitive detection of all compounds except helium and neon. Plasma is generated by applying a high voltage to a quartz dielectric chamber in the presence of helium. Compounds that elute from the GC column are ionized by this He plasma, then captured with collection electrodes and described as peaks (Fig. 4). The BID has the advantage of providing high-sensitivity detection of both inorganic and organic compounds at the sub ppm level. This advantage may potentially simplify gas analysis systems like the NGA system.

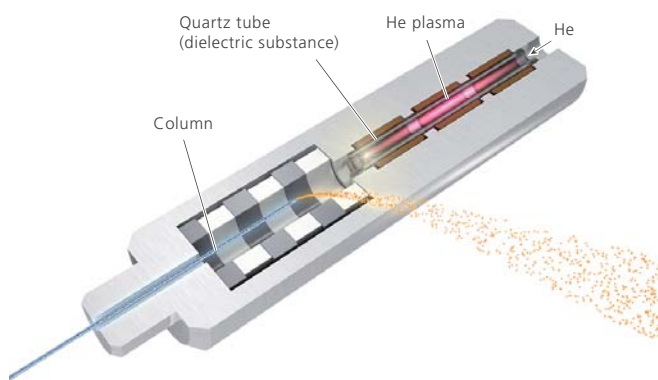

Fig. 4 Barrier discharge ionization detector (BID)

3-2. Ultrafast NGA system with BID

The ultrafast NGA system's configuration consists of three sample loops, six columns and two detectors: BID and FID. The detection range of components is shown in Table 3. H₂, O₂, N₂ and CO are separated by an Rt-MS-5A plot column (0.53 mmI.D., 50 μm, 30 m) whereas CO₂, C₂H₄, C₂H₆, C₂H₂, H₂S are separated by an Rt-Q plot column (0.53 mmI.D., 20 μm, 30 m). The ends of the two columns are joined together and the components are detected by the BID (Figs. 5, 6). CH₄ and C₃ or higher hydrocarbons are separated by an Rtx-1 column (0.53 mmI.D., 5.0 μm, 60 m) and detected by FID.

Table 3 Detection range of components of the Ultra-Fast NGA system

No.	Name of Compound	Concentration Range		Detector
		Low Conc.	High Conc.	
1	H ₂	0.001%	10.0%	BID
2	O ₂	0.001%	20.0%	BID
3	N ₂	0.001%	50.0%	BID
4	CO	0.001%	5.0%	BID
5	CO ₂	0.001%	20.0%	BID
6	C ₂ H ₄	0.001%	10.0%	BID
7	C ₂ H ₆	0.001%	10.0%	BID
8	C ₂ H ₂	0.001%	10.0%	BID
9	H ₂ S	0.01%	30.0%	BID
10	CH ₄	20.0%	100.0%	BID
11	C ₃ H ₈	0.001%	10.0%	FID
12	i-C ₄ H ₁₀	0.001%	10.0%	FID
13	n-C ₄ H ₁₀	0.001%	10.0%	FID
14	i-C ₅ H ₁₂	0.001%	2.0%	FID
15	n-C ₅ H ₁₂	0.001%	2.0%	FID
16	C ₆ ⁺	0.001%	0.5%	FID

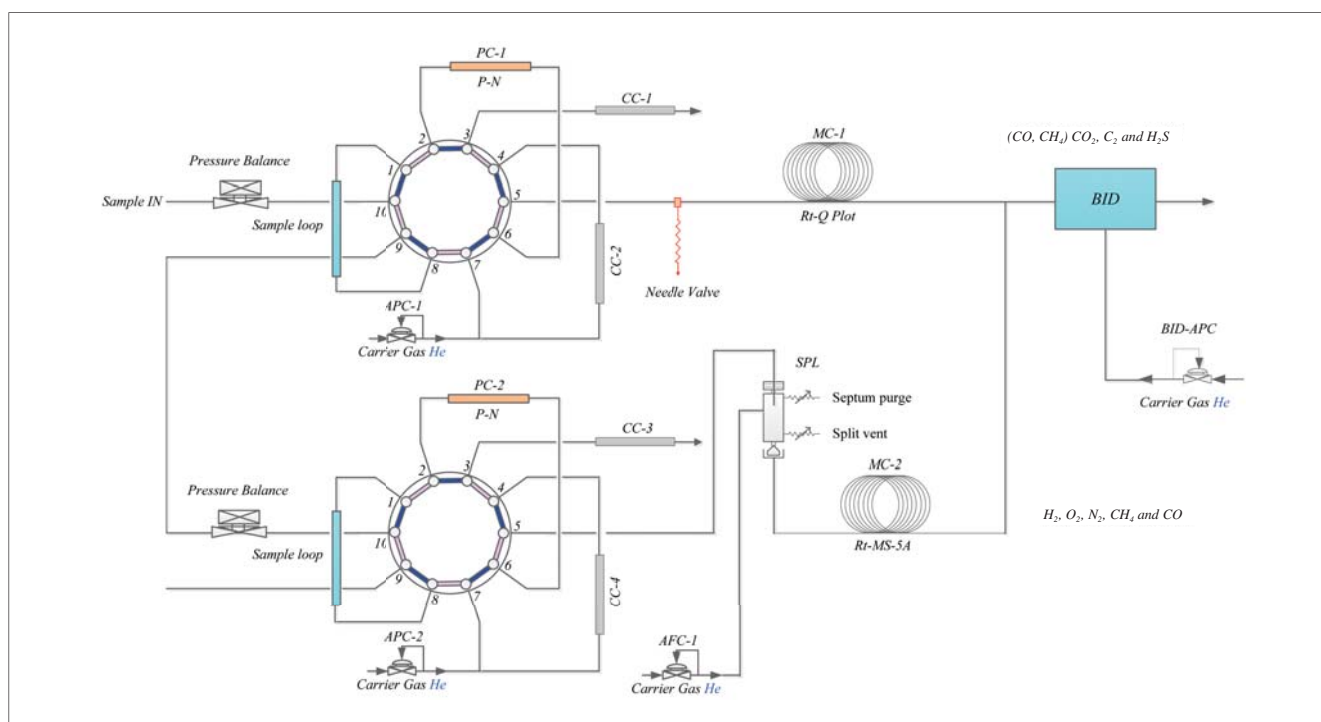

Fig. 5 Part of flow diagram of the Ultrafast NGA system (Channel of BID)

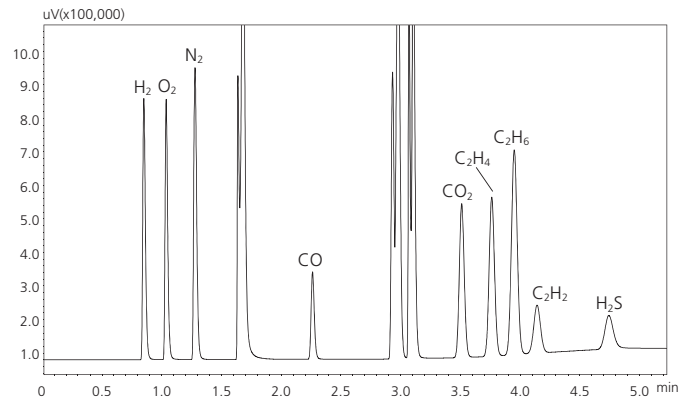

Fig. 6 Chromatogram using the Ultrafast NGA system (Channel of BID)

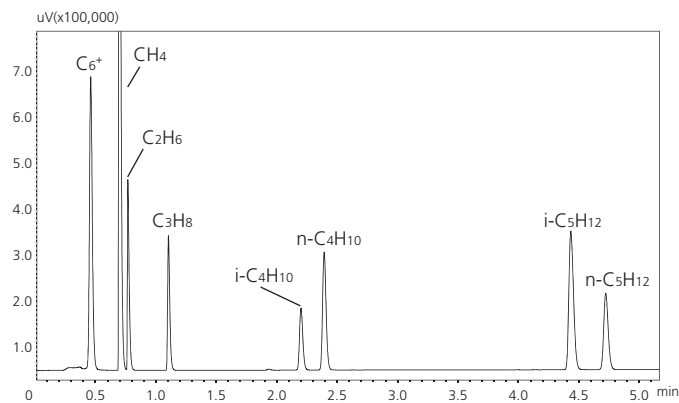

Fig. 7 Ultrafast NGA system Chromatogram (Channel of FID)

Table 4 Repeatability of peak areas of the Ultrafast NGA system (Channel of BID)

ID	Compound Name	1	2	3	4	5	6	Mean Area	RSD%
1	H ₂ (16.02%)	1,221,080	1,217,638	1,220,585	1,221,434	1,219,877	1,221,352	1,220,328	0.12
2	O ₂ (4.82%)	1,201,943	1,201,078	1,203,779	1,201,378	1,199,380	1,203,229	1,201,798	0.13
3	N ₂ (9.98%)	1,514,715	1,511,981	1,517,955	1,514,142	1,514,211	1,518,090	1,515,182	0.16
4	CO (1.02%)	486,535	487,959	489,768	487,103	487,895	488,835	488,016	0.24
5	CO ₂ (1.96%)	1,334,791	1,337,904	1,338,552	1,336,785	1,331,065	1,326,637	1,334,289	0.35
6	C ₂ H ₄ (0.998%)	1,510,314	1,513,120	1,514,393	1,512,294	1,504,769	1,499,412	1,509,050	0.38
7	C ₂ H ₆ (1.000%)	2,109,195	2,114,540	2,115,465	2,112,086	2,102,367	2,095,589	2,108,207	0.37
8	C ₂ H ₂ (0.510%)	576,087	576,805	576,730	576,121	573,434	571,868	575,174	0.35
9	H ₂ S (0.525%)	512,847	508,727	510,989	511,634	508,666	511,887	510,792	0.34

A key aspect of this system is the use of one BID instead of two TCDs for detecting inorganic components. This stems from the ability of the BID to provide high-sensitivity detection of all components. In addition, reducing the number of detectors simultaneously reduces the number of columns required. In other words, the BID simplifies analysis. In addition, because the BID is very sensitive and shows a saturated response to highly-concentrated components, unlike TCD, a small volume of sample loops (20 or 50 μ L) is used in the stream, and introduced samples are split at the front of columns. Finally, the main component CH₄ is detected by another stream in an FID. In parallel with CH₄ detection by FID, shortening the analysis time of the BID stream resulted in an analysis time of less than 5 minutes.

As Table 4 shows, the Ultrafast NGA system provides good repeatability of peak areas with the BID channel. The Ultrafast NGA system combines the best properties of high productivity and reliability, allowing operators to optimize their workflow.

4. Conclusion

Shimadzu has offered various sorts of NGA systems for decades. Current systems, such as the Fast NGA system and Ultrafast NGA system, enable high productivity and reliability. These systems' features are based on innovative ideas, such as taking advantage of capillary columns and adapting new detector technology. We will continue to develop and refine systems to meet the demands of the energy sector.

Shimadzu Establishes Innovation Centers in the U.S. and China to Promote Joint Research and Development



The SSI Innovation Center, Columbia, Maryland, U.S. (left), and the China MS Center, Beijing, China (right)

To further promote joint research and development projects with leading academic and research institutions, Shimadzu Corporation has established the SSI Innovation Center at its U.S. subsidiary, Shimadzu Scientific Instruments, Inc. (SSI), Maryland, U.S., and the Shimadzu China Mass Spectrometry Center (hereinafter the China MS Center) at the Beijing branch of its Chinese subsidiary, Shimadzu (China) Co., Ltd.

In North America, Shimadzu Corporation has been participating in joint research projects in such areas as clinical medicine, food safety, and environment testing involving the use of Shimadzu's main products, such as chromatographs and mass spectrometers. To foster more joint research and collaborative projects with customers, SSI was reorganized to establish the SSI Innovation Center for the purpose of providing feedback to product development operations as quickly as possible.

The SSI Innovation Center comprises three groups with a current total of 26 employees. These groups include Strategic Collaboration Development, Research and Development, and Application Development. R&D investment of 20 million dollars is planned over the next five years.

In the United States, the state of Maryland is home to Johns Hopkins University, the National Institutes of Health (NIH), National Cancer Institute (NCI), and many other leading academic and research institutions and companies. It is a particularly ideal environment for developing deeper partnerships in the field of clinical medicine.

The China MS Center was established for the purpose of joint research and development with researchers in China to advance mass spectrometry (MS) technology. The laboratories are equipped with high-end Shimadzu MS systems including liquid chromatograph mass spectrometers and gas chromatograph mass spectrometers. The Center will participate in the formulation of official analytical methods through new application development, and develop and improve high-end mass spectrometry systems. By providing solutions better matched to the Chinese market, Shimadzu aims to expand the market

share of its core products, centered on mass spectrometers, and to further improve the Shimadzu brand image.

As of fiscal 2015, the China MS Center has a staff of ten, a number that will be expanded as the need arises. By the end of 2016, the Center plans to invest a total of more than 460 million yen in research and development.

Due to increasing research investment in cutting-edge fields, as well as demands for speedy solutions to food safety and environmental issues, the mass spectrometry market in China is expected to expand. In 2016 Shimadzu expects the scale of the mass spectrometry market in China to increase by approximately 1.3 times the value in 2013. Therefore, the goal is to succeed in the market through the activities of the China MS Center and improve our business performance. In addition, results obtained at the China MS Center will be fed back to Shimadzu in Japan and deployed to other regions, thereby leveraging the results in product and application development at various sites around the world.

The general manager of the Analytical & Measuring Instruments Division, Shuzo Maruyama, said: "Due to the concentration of clinical medicine and healthcare research institutions like the NIH in North America, and particularly in the Northeast United States, it is an ideal location for developing applications for our analytical and measuring instruments in those fields. As for the China MS Center, research activities in mass spectrometry in China have impacts internationally, contributing significantly to its development. Under such circumstances, Shimadzu will work to contribute further to mass spectrometry technology in China and globally, through the activities at this Center. To take maximum advantage of Shimadzu's strengths and advantages in markets around the world, we plan to establish similar facilities based on a global innovation center concept in other regions as well. We expect these facilities will serve as a driver of new product development for the Analytical & Measuring Instruments Division."

Shimadzu Teams with the University of Wisconsin-Milwaukee to Form Interdisciplinary Chemistry Lab



Shimadzu Scientific Instruments (SSI) announces the opening of the Shimadzu Laboratory for Advanced Applied and Analytical Chemistry at the University of Wisconsin-Milwaukee (UWM). The new 2,000-square-foot laboratory and office suite is a hub for research across the entire UWM campus, as well as a classroom for teaching the theory and practice of mass spectrometry. The new lab, located inside of UWM's Kenwood Interdisciplinary Research Complex, was made possible by a \$1.13 million grant from Shimadzu Scientific Instruments.

Equipped with an array of Shimadzu's analytical instruments, the lab is able to support diverse programs in drug discovery, freshwater science, food and beverage, environmental science, and other basic life science and chemistry studies. The facility features six state-of-the-art mass spectrometers, sample preparation tools, UV-visible and FTIR spectrometers, liquid and gas chromatography systems, and a fully equipped tissue culture suite to enable discovery and toxicology research.

The Milwaukee Institute for Drug Discovery (MIDD), part of UWM's Department of Chemistry and Biochemistry, is the primary user of the lab. The institute uses the lab to conduct NIH-funded research on new drugs for pain, schizophrenia, and asthma, as well as anti-infective and anti-cancer drugs. MIDD frequently uses the instrumentation for

structural analysis of newly synthesized drug compounds, assessment of drug metabolism and stability, and pharmacokinetics and bio-distribution. Neuroscientists at the university have adopted the MALDI-TOF MS for studies on central nervous system development, pain processes, and learning.

"Our relationship with Shimadzu allows us ready access to the market's latest analytical innovations," said Dr. Douglas Stafford, Director of MIDD. "In the future, we hope that this lab will be used to host user workshops on new applications and instruments. This will help to keep our scientists ahead of the curve by staying connected to the wide network of MS users."

"The University of Wisconsin-Milwaukee, in conjunction with MIDD, is a vibrant, growing research community, supporting interdisciplinary applications in numerous scientific programs," said Terry Adams, VP Marketing at Shimadzu Scientific Instruments. "Shimadzu is proud to have our name associated with such an outstanding institution and we are eager to work with the many researchers and students utilizing this impressive laboratory."

For more information on the Shimadzu Laboratory for Advanced and Applied Analytical Chemistry, go to <http://www4.uwm.edu/drugdiscovery/>

Shimadzu Partners with Miyazaki Prefecture in Establishing an Incorporated Association to Analyze Food Safety



The Miyazaki Agricultural Research Institute which holds the new incorporated association

Shimadzu Corporation has established an incorporated association in partnership with Miyazaki Prefecture to analyze the safety of food. The association will undertake analyses of residual pesticides in agricultural and food products. The opening ceremony was held on November 5 at the Miyazaki Agricultural Research Institute, and was attended by the Governor of Miyazaki Prefecture, Shunji Kouno, and by Kozo Miseki, Deputy General Manager of the Analytical & Measuring Instruments Division, Shimadzu Corporation. About 30 people participated in the event.

Miyazaki Prefecture is one of Japan's major food supply areas, and already has in place a top-level inspection system called the "Miyazaki Method," which utilizes a unique technology for analyzing residual pesticides. The prefecture has been successful in branding several of its agricultural products. The incorporated association was established with the goal of applying the analysis technology widely within the agricultural and food industries, both inside and outside Miyazaki Prefecture, in order to contribute to the improvement of food safety and to the development of industry.

The incorporated association has installed the first unit of the Nexera UC supercritical fluid extraction/chromatography system, which was developed by Shimadzu Corporation with the assistance of the Japan Science and Technology Agency (JST) and in collaboration with Osaka University, Kobe University and Miyazaki Prefecture. The Nexera UC features technology patented by Miyazaki Prefecture, and offers not only complete automation of the analysis processes, including sample

preparation, but also extremely high sensitivity. The system has significantly shortened the turn-around-time from test acceptance through to production of the report.

At the opening ceremony, Governor Kouno greeted attendees saying "I hope that we will be able to continue our joint research into residual pesticide analysis and functional ingredients, allowing Miyazaki to contribute to the availability of safer food products and to consumers' greater peace of mind." Deputy General Manager Miseki said "It is truly an honor for Shimadzu that the Nexera UC is able to play such a role in ensuring food safety based on science and technology."



The first unit of the Nexera UC supercritical fluid extraction/chromatography system

New Products

ICPMS-2030

(Inductively Coupled Plasma Mass Spectrometer)

Offering Outstanding Reliability, Exceptional Ease of Use, and The Industry's Lowest Operating Costs



[Click here>>](#)

Featuring unique analysis assistant functions and incorporating proprietary cost-reducing capabilities, the ICPMS-2030 provides efficient, sensitive trace element analysis for environmental testing, food and agriculture studies, and pharmaceutical work.

Features

- Designed for high sensitivity and easy maintenance
- Simplified analysis and higher data reliability using assistant functions and LabSolutions software
- Reduced Argon gas consumption and lower running costs with a mini-torch and eco mode

EDX-7000/8000

(Energy Dispersive X-ray Fluorescence Spectrometers)

Now Compliant with US FDA 21 CFR Part 11 Electronic Records; Electronic Signatures



[Click here>>](#)

The EDX-7000/8000 energy dispersive X-ray fluorescence spectrometers are now compliant with the 21 CFR Part 11 Electronic Records; Electronic Signatures guideline, which is designated by the U.S. Food and Drug Administration (FDA).

Features

- Four easy steps
- Enables FDA 21 CFR Part 11 compliance needed in pharmaceutical industry
- LabSolutions DB/CS data management offers higher efficiency
- Drug impurities analysis using X-ray fluorescence

GCMS-QP2020

(Gas Chromatograph Mass Spectrometer)

Offering Excellent Qualitative and Quantitative Performance for a Diverse Range of Applications



[Click here>>](#)

The GCMS-QP2020 achieves the highest sensitivity in its class and enables high-speed performance for an array of applications. In addition, it adopts a new turbomolecular pump with improved exhaust efficiency. This provides higher accuracy in analysis, even when hydrogen or nitrogen is used as the carrier gas instead of helium.

Features

- High performance mass spectrometer supports various analytical conditions
- GCMS insight package for more efficient multicomponent simultaneous analyses
- Diversified application systems using retention indices

GC/MS Off-Flavor Analyzer

Analytical System for Reliably Identifying Odor-Causing Substances



[Click here>>](#)

This system combines a database of the major odor-causing substances and associated sensory information (odor characteristics and threshold levels for sensing odors) with a gas chromatograph mass spectrometer (GC-MS).

Features

- Database of expert information for odor analysis
- Analytical system for reliably identifying odor-causing substances
- Application solution-based system



Find us on 



Linked 



Shimadzu Corporation
www.shimadzu.com/an/

For Research Use Only. Not for use in diagnostic procedures.
The content of this publication shall not be reproduced, altered or sold for any commercial purpose without the written approval of Shimadzu.
The information contained herein is provided to you "as is" without warranty of any kind including without limitation warranties as to its accuracy or completeness. Shimadzu does not assume any responsibility or liability for any damage, whether direct or indirect, relating to the use of this publication. This publication is based upon the information available to Shimadzu on or before the date of publication, and subject to change without notice.

© Shimadzu Corporation, 2016
Printed in Japan, April, 2016