

Application News

Monitoring of Sulfur Components by Simultaneous Analysis Using GC-MS and GC-SCD

Y. Takemori

User Benefits

- ◆ Use of a detector splitting system makes it possible to transport components to multiple detectors and obtain multiple chromatograms in a single analysis.
- ◆ This system enables simultaneous analysis using a GC-MS (comprehensive analysis) and GC-SCD (analysis limited to sulfur compounds).

Introduction

Fossil fuels contain varying concentrations of sulfur compounds, and lax control of the concentration in final products can cause environmental pollution and reduced catalyst performance in automotive exhaust gas purification systems¹⁾. Sulfur compounds can also cause catalyst poisoning, resulting in deterioration of various catalysts. Based on this background, monitoring and identification of sulfur compounds in samples is important. In this article, samples were transported simultaneously to an MS and an SCD (sulfur chemiluminescence detector) in the same analysis by using a combination of a LabSolutions™ GCMS and a detector splitting system, enabling quick confirmation and identification of the contents of sulfur components.

LabSolutions and Detector Splitting System

LabSolutions GCMS and a Shimadzu detector splitting system were used to enable simultaneous analysis by the GC-MS and GC-SCD. Fig. 1 shows an outline of the system.

- LabSolutions GCMS DB and CS systems are comprehensive software for management of the data in databases for LC, GC, LCMS, and GCMS, and enable GC and GCMS analysis with one program.
- The detector splitting system branches downstream of the analysis column and makes it possible to acquire multiple chromatograms in one analysis by transporting the separated components to multiple detectors. The dedicated detector splitting device has a low dead volume and is treated with an inert coating parts to ensure low sample adsorption.

Performance Validation of System

For the performance validation of this system, a sample was prepared by adding 5 sulfur compounds to isooctane to a concentration of 0.1 ppm, and carrying out an analysis under the conditions in Table 1.

Table 1 Instrument Configuration and Analysis Conditions of Performance Validation

Model	: GCMS-QP2020 NX
GC	
Injection Volume	: 1 µL (using AOC™-30i)
Injection	: SPL
Injection Temp.	: 330 °C
Injection Mode	: Split
Split Ratio	: 1 : 15
Carrier Gas	: He
Carrier Gas Control	: Linear velocity (45 cm/s)
Column	: SH-I-1MS (30 m × 0.32 mm I.D., 4.00 µm) ^{*1}
Column Temp.	: 50 °C - 15 °C/min - 330 °C (2 min)
Detector	: Nexis™ SCD-2030
Interface Temp.	: 280 °C
Electric Furnace Temp.	: 850 °C
Detector Gas	: H ₂ 80.0 mL/min, N ₂ 40.0 mL/min O ₂ 10.0 mL/min, O ₃ 25.0 mL/min
Detector splitting system ^{*2}	: Micro Channel 4-Port Splitter
Resistance tube	: 0.5 m × 0.15 mm I.D. (*for both MS and SCD lines)
Detector branch ratio	: SCD : MS = 1 : 1.03
AUX-APC	: 20 kPa
MS (EI method)	
Ion Source Temp.	: 230 °C
Interface Temp.	: 300 °C
Ionization Mode	: EI
Measurement Mode	: Scan
Event Time	: 0.3 s

*1 P/N: 227-36011-01

*2 Detector splitting package (Splitter device + APC)
SMI FLOW DEVICE 2-Way Splitter with APC : 221-88100-41

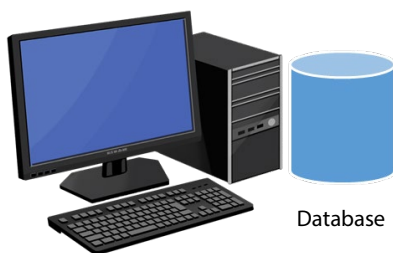

The LabSolutions GCMS DB and CS systems enable analysis by either GCMS or GC.

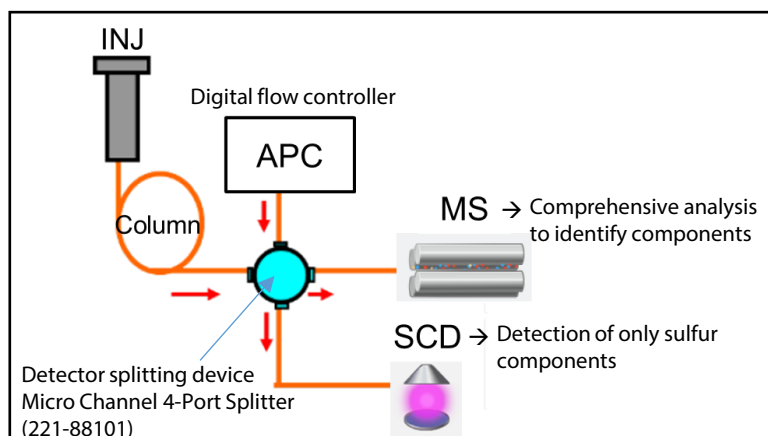

Fig. 1 LabSolutions GCMS and Detector Splitting System

■ Results of System Performance Validation

Fig. 2 shows the GC-SCD chromatogram when a sample with a 0.1 ppm concentration of each of the sulfur compounds was analyzed with this system. The results confirmed that analysis is possible even at a low concentration of 0.1 ppm. In particular, satisfactory analysis results were obtained even with 2,2'-Dithiodipyridine, which is an amine with high adsorption.

*High boiling components that elute later than these constituents may cause reduced recovery compared with a direct connection to the column.

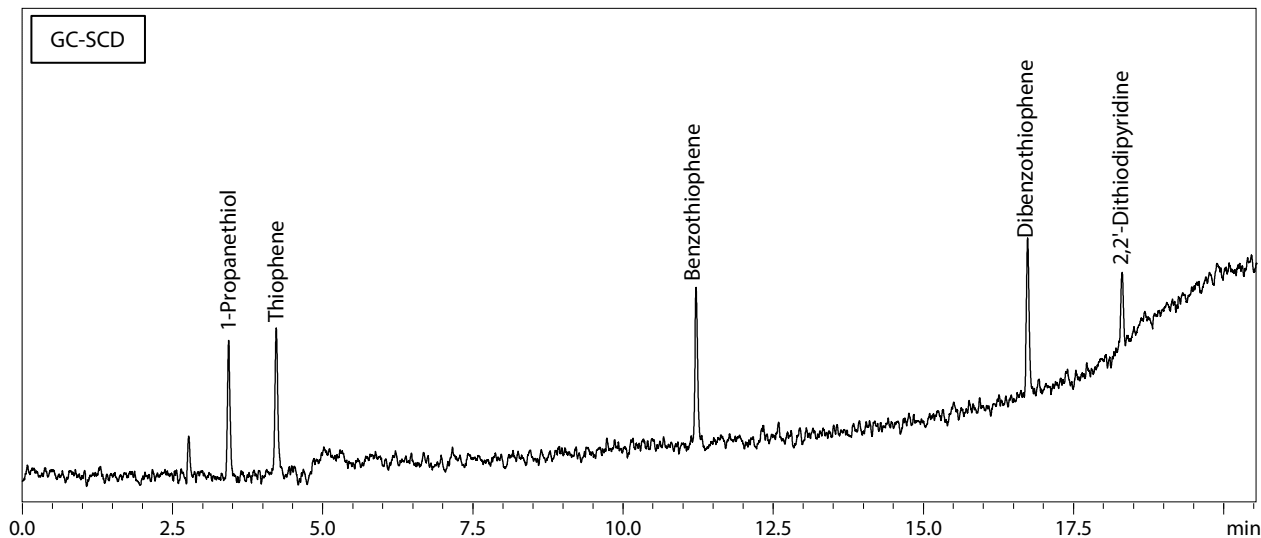

Fig. 2 GC-SCD Chromatogram of Analysis of Sample with Sulfur Compound Concentrations of 0.1 ppm

■ Analysis of Light Oil Sample by System

As a real sample, light oil (diesel fuel) with a sulfur content of 300 mass ppm level (The Japan Petroleum Institute: P/N: S0711) was analyzed under the conditions in Table 2.

Table 2 Instrument Configuration and Analysis Conditions of Light Oil Sample

Model	: GCMS-QP2020 NX
<u>GC</u>	
Injection Volume	: 1 μ L (using AOC-30i)
Injection	: SPL
Injection Temp.	: 330 °C
Injection Mode	: Split
Split Ratio	: 1 : 50
Carrier Gas	: He
Carrier Gas Control	: Linear velocity (35 cm/s)
Column	: SH-I-1MS (P/N 227-36011-01) (30 m \times 0.32 mm I.D., 4.00 μ m)
Column Temp.	: 120 °C - 15 °C/min - 330 °C (10 min)
Detector	: Nexis SCD-2030
Interface Temp.	: 280 °C
Electric Furnace Temp.	: 850 °C
Detector Gas	: H ₂ 80.0 mL/min, N ₂ 40.0 mL/min O ₂ 10.0 mL/min, O ₃ 25.0 mL/min
Detector splitting system	: Micro Channel 4-Port Splitter
Resistance tube	: 0.5 m \times 0.15 mm I.D. (*for both MS and SCD lines)
Detector branch ratio	: SCD : MS = 1 : 1.03
AUX-APC	: 20 kPa
<u>MS (EI method)</u>	
Ion Source Temp.	: 230 °C
Interface Temp.	: 300 °C
Ionization Mode	: EI
Measurement Mode	: Scan
Event Time	: 0.3 s



System Used in Experiment
GCMS-QP 2020 NX + Nexis™ SCD-2030 + AOC-30i

■ Results of Analysis of Light Oil Sample

Fig. 3 shows the total ion chromatogram (TIC) obtained with the GC-MS when the light oil sample was analyzed with this system, and Figs. 4 and 5 show the GC-SCD chromatogram. The TIC and GC-SCD chromatograms were acquired simultaneously. From TIC result, numerous peaks, such as carbon hydrides of main components and others, were detected.

On the other hand, only sulfur components were detected in the GC-SCD chromatogram. These components had been missed in the TIC analysis because they overlapped with other compounds in the TIC. As sulfur components in the light oil sample, a sulfur compound with a comparatively high concentration was detected in the vicinity of R_t : 6.7 min, and the existence of multiple other sulfur compounds was also confirmed.

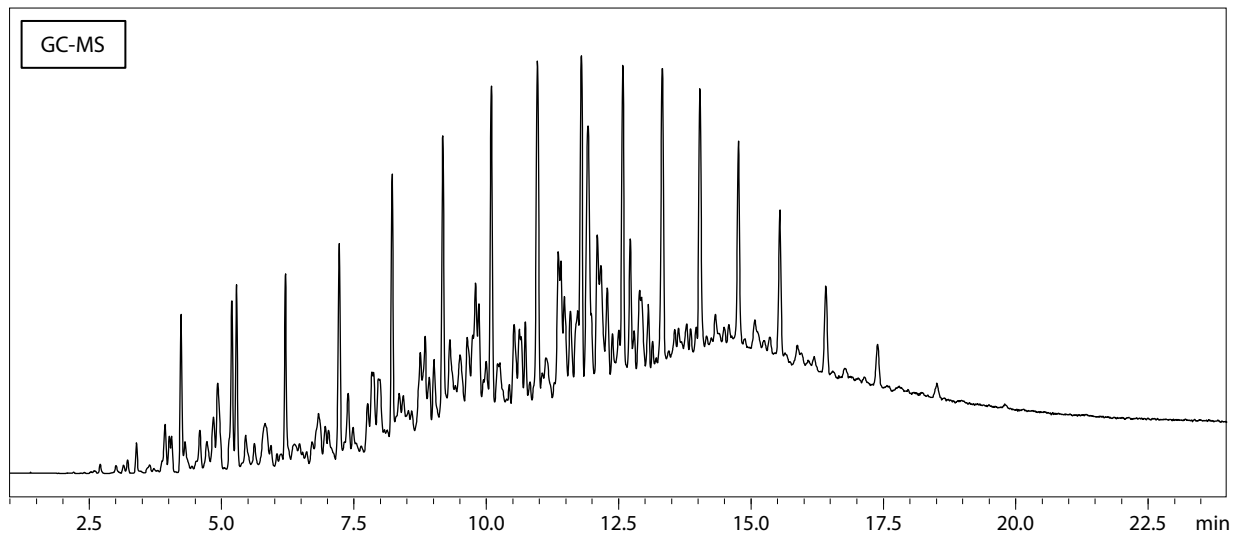

Fig. 3 GC-MS Total Ion Chromatogram of Simultaneous Analysis of Standard Sample of Light Oil with a Sulfur Content of 300 mass ppm level

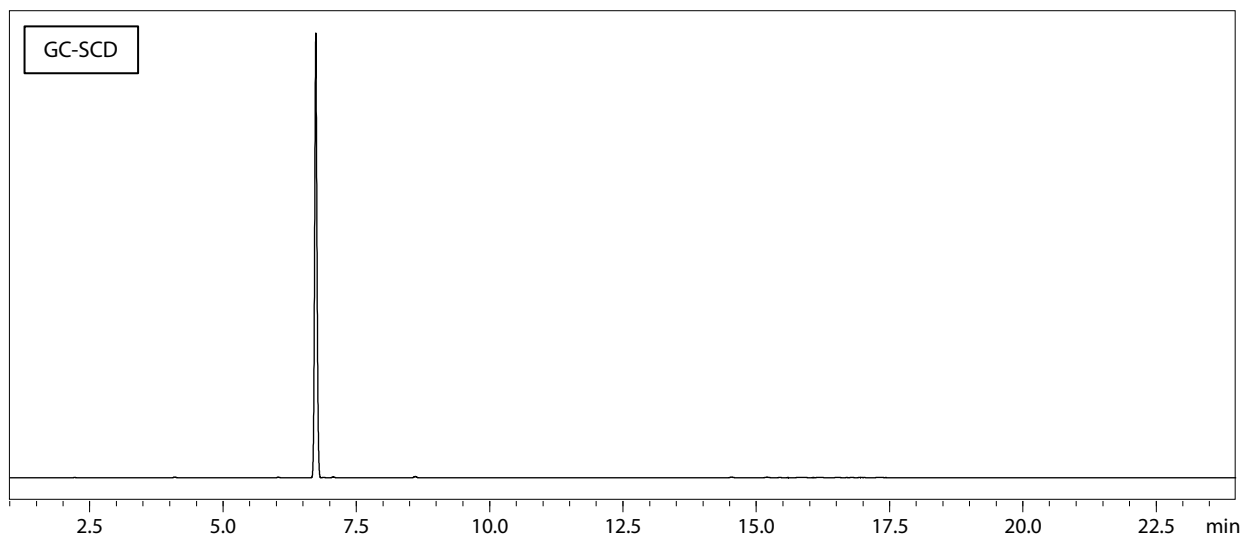

Fig. 4 GC-SCD Chromatogram of Simultaneous Analysis of Standard Sample of Light Oil with a Sulfur Content of 300 mass ppm level (Total Chromatogram)

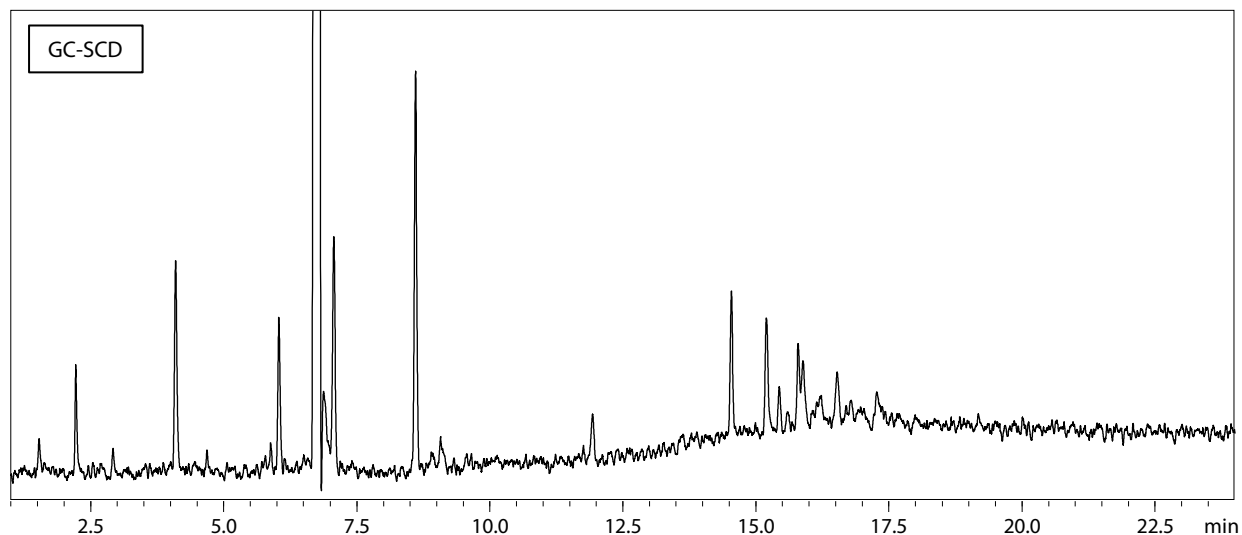

Fig. 5 GC-SCD Chromatogram of Simultaneous Analysis of Standard Sample of Light Oil with a Sulfur Content of 300 mass ppm level (Enlargement)

■ Identification of Sulfur Components

In order to identify the above-mentioned sulfur components, we focused on the vicinity of the sulfur component detected by GC-SCD at around Rt : 6.7 min. As a result of a library search in the area of this time in TIC of GC-MS, this peak could be identified as Di-tert-butyl disulfide (Fig. 6). Thus, it was possible to detect and identify sulfur compounds that had been missed by conducting a simultaneous analysis using GC-SCD and GC-MS.

■ Conclusion

An analysis was conducted by simultaneously transporting the sample to an MS and SCD in a single analysis using a combination of LabSolutions GCMS and a detector splitting system. Simultaneous analysis by GC-MS and GC-SCD made it possible to identify sulfur compounds that had been overlooked in the GC-MS analysis due to overlapping with other components.

(a) Total ion chromatogram

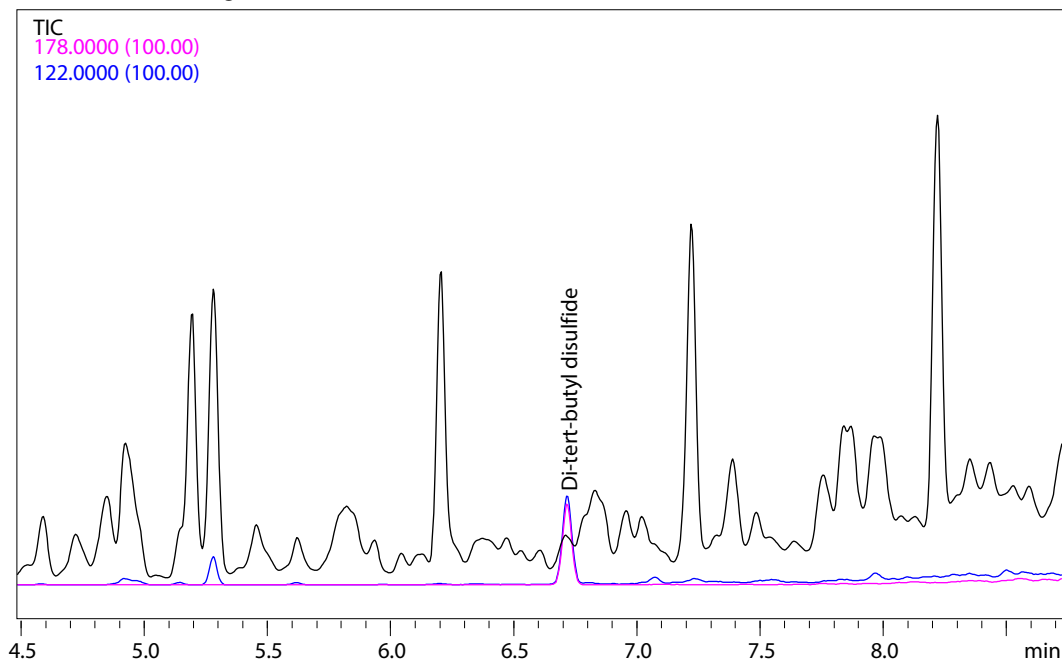

(b) Result of library search

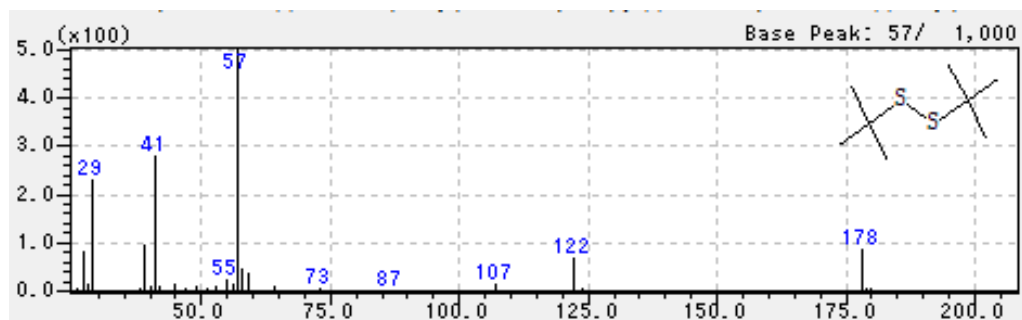

Fig. 6 (a) GC-MS Total Ion Chromatogram in Vicinity of Elution Time Where Sulfur Compound was Detected by GC-SCD and (b) Result of Library Search

<Reference>

- 1) Yuko Kitamaki, A Study on Sulfur Standard Materials, AIST Bulletin of Metrology, Vol. 4, No. 3 (2006)

LabSolutions, Nexis, and AOC are trademarks of Shimadzu Corporation or its affiliated companies in Japan and/or other countries.



Shimadzu Corporation

www.shimadzu.com/an/

For Research Use Only. Not for use in diagnostic procedures.

This publication may contain references to products that are not available in your country. Please contact us to check the availability of these products in your country.

The content of this publication shall not be reproduced, altered or sold for any commercial purpose without the written approval of Shimadzu. See <https://www.shimadzu.com/about/trademarks/index.html> for details.

Third party trademarks and trade names may be used in this publication to refer to either the entities or their products/services, whether or not they are used with trademark symbol "TM" or "®".

Shimadzu disclaims any proprietary interest in trademarks and trade names other than its own.

The information contained herein is provided to you "as is" without warranty of any kind including without limitation warranties as to its accuracy or completeness. Shimadzu does not assume any responsibility or liability for any damage, whether direct or indirect, relating to the use of this publication. This publication is based upon the information available to Shimadzu on or before the date of publication, and subject to change without notice.

01-00206C-EN

First Edition: Sep. 2021
Revision B: Mar. 2023
Revision C: Jan. 2026

➤ Please fill out the survey

Related Products

Some products may be updated to newer models.



➤ **LabSolutions™**
GCMS
Analytical Data System for GCMS



➤ **Nexis™ GC-2030**
Gas Chromatograph



➤ **GCMS-QP2020 NX**
Gas Chromatograph Mass Spectrometer



➤ **Nexis™ SCD-2030**
Sulfur Chemiluminescence Detection
Gas Chromatograph



SH Series
➤ **SH-I-1MS**

Related Solutions

Hydrocarbon
➤ Processing Industry
(Petrochemical, Chemical)

➤ Clean Energy

➤ Automotive

➤ Food and Beverages

➤ Price Inquiry

➤ Product Inquiry

➤ Technical Service /
Support Inquiry

➤ Other Inquiry