

Evaluation of Press Work on Sheet Metal

— Obtaining Accurate Design Data Usable for Simulation —

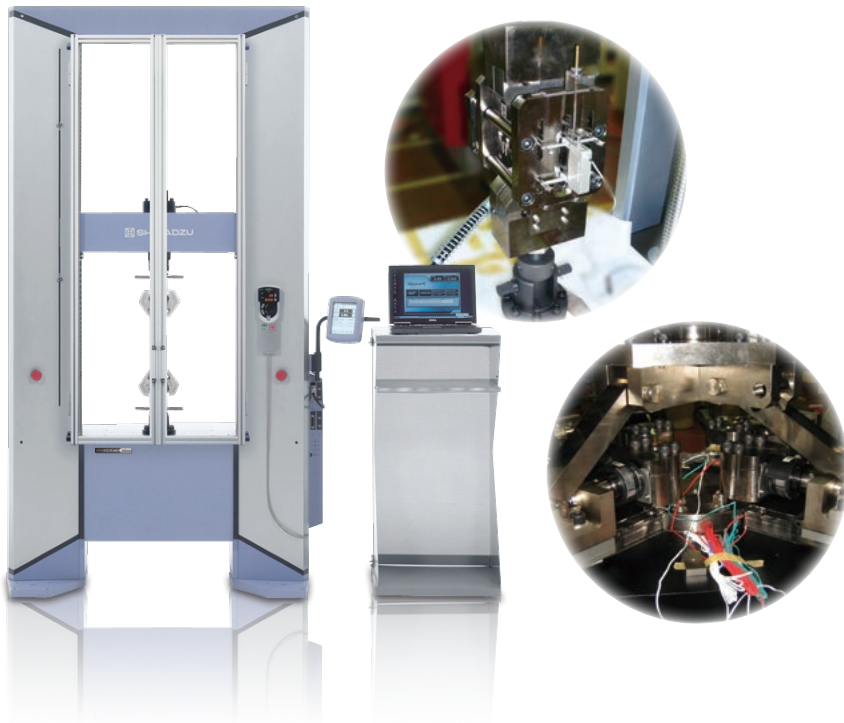

Evaluation of Press Work on Sheet Metal

Pressed parts made of lightweight materials with poor workability, such as high tensile steel, aluminum alloys, and magnesium alloys, are essential for reducing the weight of transportation equipment. Repeatedly modifying the die to achieve a target shape not only increases costs, but also lengthens the development period. One solution currently being tried is to reduce the number of actual samples evaluated by using simulation to predict forming problems in advance. As simulation technology continues to evolve, the use of methods such as the Yoshida-Uemori Model¹⁾, which considers a greater number of factors than previous methods, including plastic strain dependence of elasticity based on the r-value and the Bauschinger effect, has increased. Due to improvements in simulation techniques, this catalog describes various testing and evaluation methods, including new evaluation methods, considered necessary for improving simulation accuracy.

1) Vol.54 (2013) No.4 SOKEIZAI 16-19



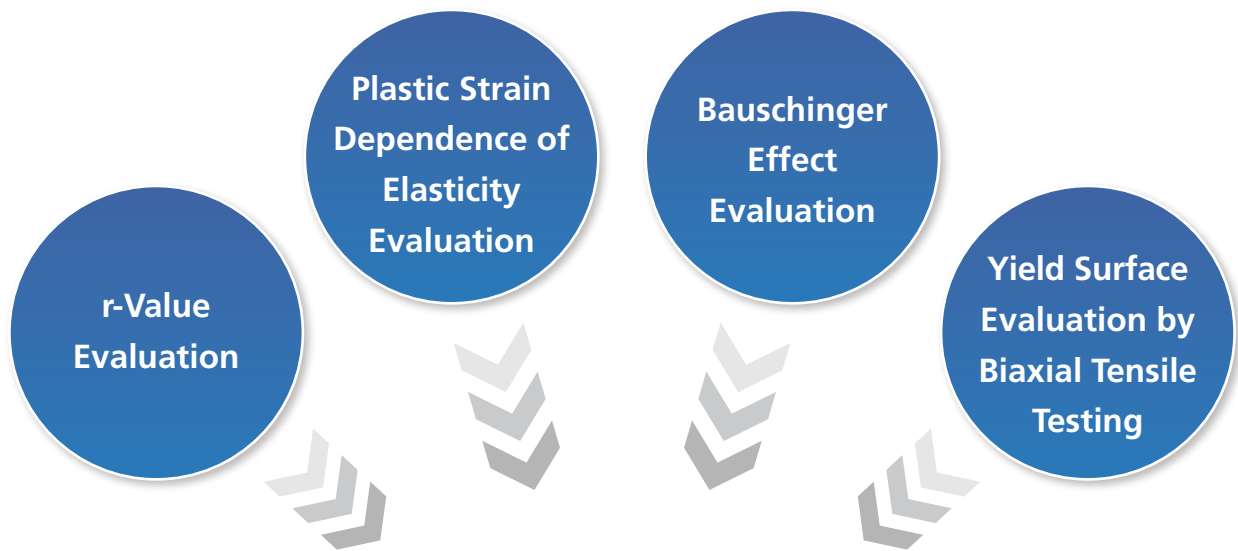

Using an Autograph Machine Allows You to Comprehensively Evaluate Properties with Respect to Press Forming.



Autograph AG-X plus Series

This provides evaluations that result in more accurate simulations.

Process Flow for Evaluating Press Workability

— Obtaining Accurate Design Data Usable for Simulation —

r-Value Evaluation

The r-value is used to evaluate press workability. It is expressed as a logarithmic strain ratio of deformation in the width and thickness directions.

A material with a high r-value, for example, does not deform much in the thickness direction, but deforms readily in the width direction. That means the material is easy to press form into a three-dimensional shape with minimal change in thickness.

Testing precision can vary significantly depending on how strain gauges are affixed or extensometers are attached.

Autograph AG-X plus machines feature an automatic extensometer that automates the extensometer attachment process and a digital non-contact extensometer, which enable highly reproducible test results.

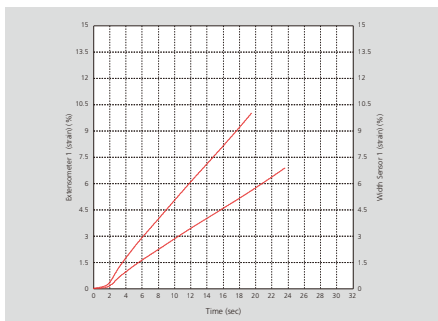
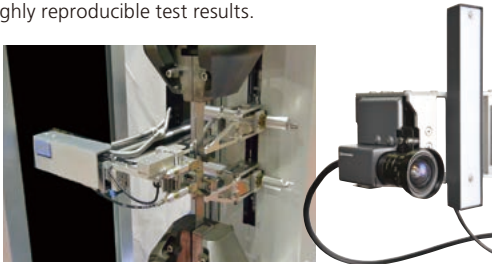

TRViewX allows non-contact measurement of elongation by simply marking gauge lines.

For specifications, see page 6.

Plastic Strain Dependence of Elasticity Evaluation

Springback is inversely proportional to the elastic modulus. The elastic modulus of sheet materials varies due to the tensile bending-unbending process during press forming. Therefore, more accurate results can be obtained by incorporating these elastic modulus variations in simulations.

TRAPEZIUM X control software allows specifying complicated cyclic loading parameters and changing the elastic modulus calculation range with ease. As a result, data can be obtained in a timely manner based on parameters required for simulation.

	Axis1	Axis2	Axis3	Axis4	Axis5	Axis6	Axis7	Axis8
Unit	mm	mm	mm	mm	mm	mm	mm	mm
Stroke	100	100	100	100	100	100	100	100
Stroke	1000	1000	1000	1000	1000	1000	1000	1000
Stroke	mm/min	mm/min	mm/min	mm/min	mm/min	mm/min	mm/min	mm/min
Details	Details	Details	Details	Details	Details	Details	Details	Details
Channel	Face	Face	Ext 1	Face	Face	Face	Ext 1	Face
Change point	100	1500	0.08	0.1	100	1500	0.09	0.1
Unit	mm	mm	mm	mm	mm	mm	mm	mm
Set	Set	Set	Set	Set	Set	Set	Set	Set
GetData	Force Ext 1	Force Ext 1	None	None	Force Ext 1	Force Ext 1	None	None
SetData	Stroke	Same as prev. area Same as prev. area	Same as prev. area	Stroke	Same as prev. area Same as prev. area	Stroke	Same as prev. area Same as prev. area	Stroke
Load	None	None	None	None	None	None	None	None

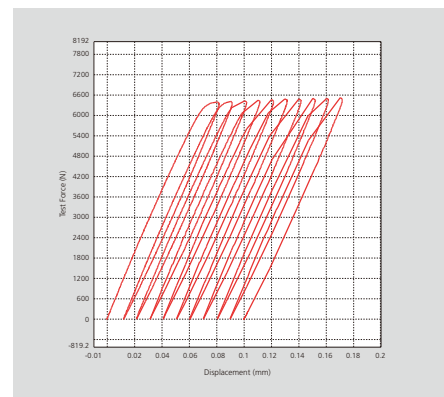

For specifications, refer to the Trapezium X product catalog.

See page 7 for details.

Bauschinger Effect Evaluation

Press forming generates a Bauschinger effect, a situation in which yield stress decreases in sheet materials due to the bending-unbending process.

Conventional press forming simulations did not account for the Bauschinger effect, which prevented fully reproducing the material behavior. Evaluating Bauschinger effects in a material allows identifying input parameters and results in more accurate simulations.

Determining the press forming workability requires evaluating the Bauschinger effect in that material. However, compression testing of a sheet material to large deformation levels without buckling the material is quite difficult, so it is rarely done.

By installing a special jig, though, this difficult evaluation can be performed using an Autograph machine.

A comb-shaped guide is included to prevent buckling. This allows performing tests involving large-deformation tensile-compression in-plane reversing loads within a range not previously possible.

Due to the difficulty of tensile-compression in-plane reversing load testing of micro specimens, Shimadzu also offers a jig that allows evaluating the Bauschinger effects using cantilever bending tests.

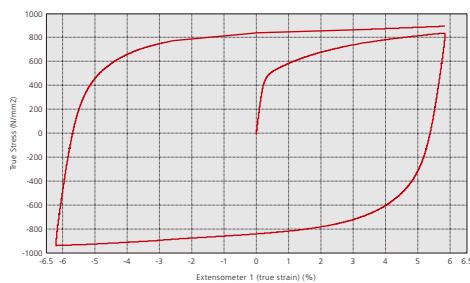
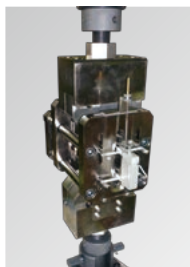

See page 8 for details.

Yield Surface Evaluation by Biaxial Tensile Testing

During actual press forming, materials are exposed to forces other than from uniaxial deformation behavior. Therefore, due to the different loading status, uniaxial evaluations alone can result in predicted behavior that does not match reality.

Evaluations can be performed with the actual loading status more closely approximated by measuring samples with loads applied in two axis directions, which should improve the accuracy of simulations.

Efforts to perform biaxial tensile testing are often abandoned due to the complicated equipment and sample setup required, high cost, and difficulty determining an appropriate specimen shape.

To address these issues, Shimadzu developed a special jig that allows biaxial tensile testing by simply attaching it to an Autograph testing machine. This means biaxial testing equipment can be obtained for a minimal cost.

The jig is also compliant with ISO 16842 standards, so it can be used to test small cruciform specimens much more easily than in the past.

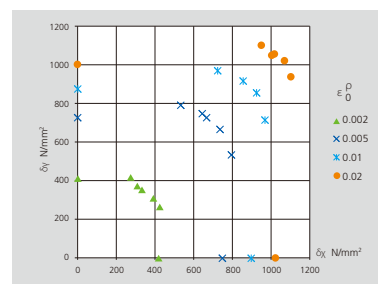
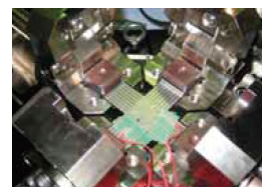

See page 10 for details.

Automatic Extensometers Capable of Measuring r-Value

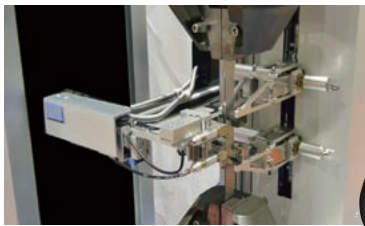

SIE-560/560S Automatic Extensometer



TRViewX Non-Contact Automatic Extensometer

Changes in both elongation and width over time can be evaluated.

Select the optimal system from a wide variety of available models, such as contact, non-contact, and manual models.

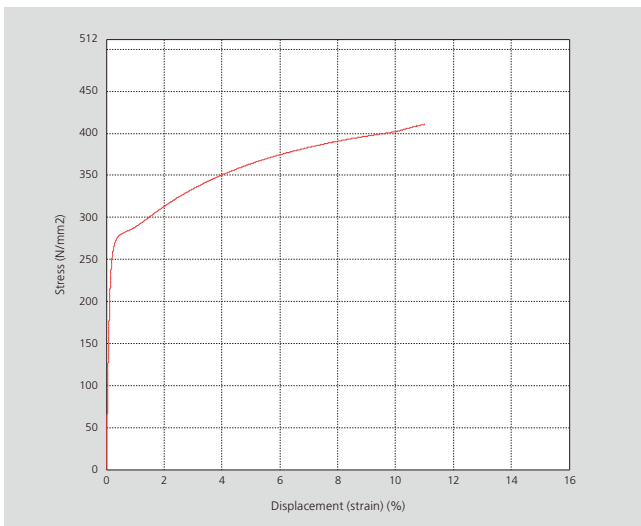

Stress vs. Strain Curve

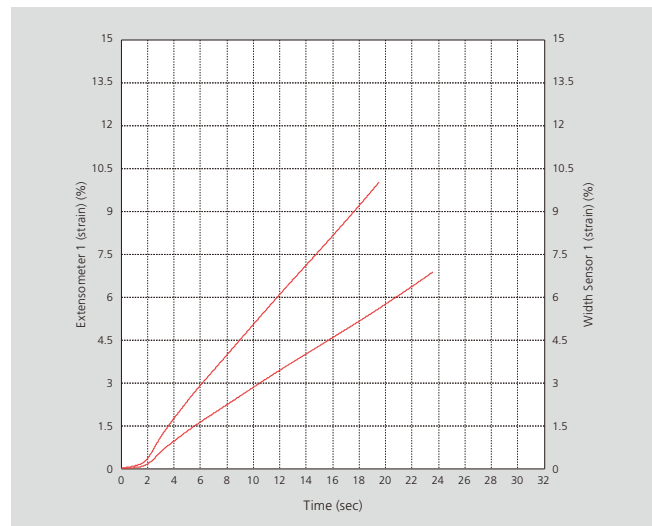

Extensometer Strain and Width Sensor Strain vs. Time Curve

Automatic Extensometer Specifications

Applicable Test Standards	JIS Z 2241 (ISO 6892) Metallic materials – Tensile testing – Method of test at room temperature JIS Z 2253 (ISO 10275) Metallic materials – Sheet and strip – Determination of tensile strain hardening exponent JIS Z 2254 (ISO 10113) Metallic materials – Sheet and strip – Determination of plastic strain ratio		
Applicable Testing Machine	Autograph series		
Elongation Measurement			
	Contact Type		Non-Contact Type
Measurement Precision	ISO 9513 class 1 (JIS B 7741 class 1) Either ± 0.5 % of indicated value or ± 2.5 μm , whichever is larger	Measurement Precision	ISO 9513 class 0.5 (JIS B 7741 class 0.5) Either ± 0.5 % of indicated value or ± 1.5 μm , whichever is larger
Measurement Range	(560 - initial gauge length) mm	Field-of-View	240 mm
Applicable Gauge Length	10 to 550 mm	Applicable Gauge Length	Min. 10 mm
Width Measurement			
	Contact Type		Non-Contact Type
Measurement Precision	ISO 9513 class 0.2 (JIS B 7741 class 0.2) Either ± 0.2 % of indicated value or ± 0.6 μm , whichever is larger	Measurement Precision	ISO 9513 class 1 (JIS B 7741 class 1) Either ± 0.5 % of indicated value or ± 2 μm , whichever is larger
Measurement Range	4 mm	Field of View Range	120 mm
Applicable Gauge Length	0.2 to 10 mm thick by 12.5, 20, 25, or 30 mm wide	Applicable Specimens	Within field-of-view range

TRAPEZIUM X: Capable of Evaluating Plastic Strain Dependence of Elasticity

In addition to stress-strain curves, test force and displacement as a function of time can be displayed in real time.

TRAPEZIUM X supports evaluating the plastic strain dependence of elasticity via user-friendly graphs.

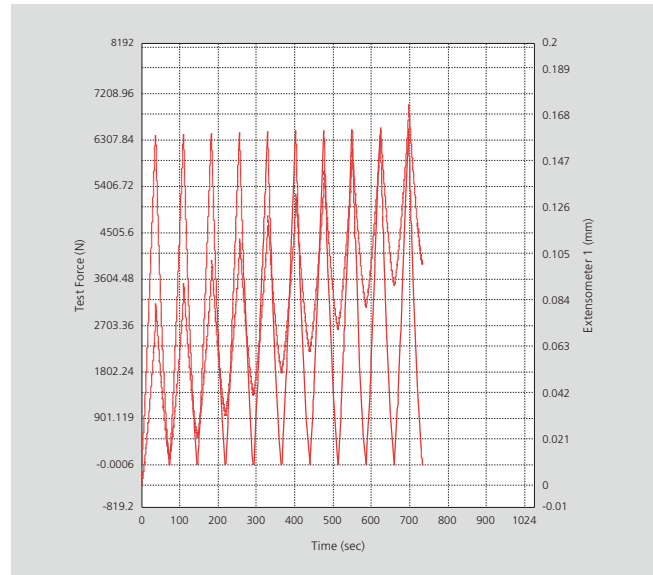
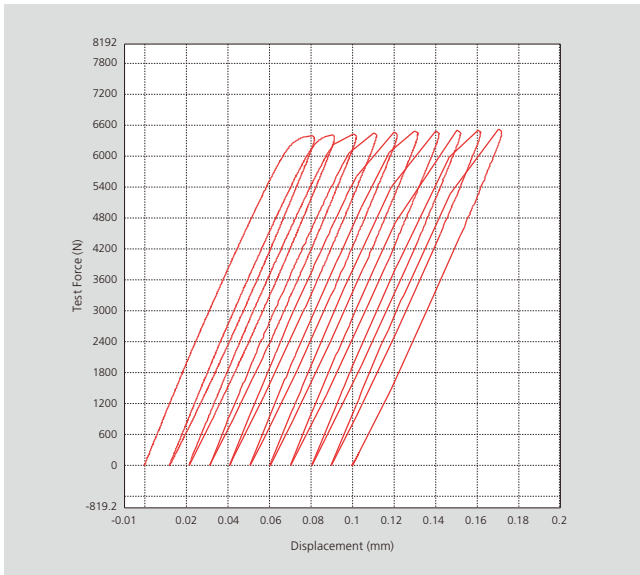

The control software allows you to specify even complicated test parameters in an easy-to-understand manner for more efficient testing.

	Area1	Area2	Area3	Area4	Area5	Area6	Area7	Area8
Act.	Up	Up	Up	Down	Up	Up	Up	Down
	Stroke	Stroke	Stroke	Stroke	Stroke	Stroke	Stroke	Stroke
	1.000	1.000	1.000	1.000	1.000	1.000	1.000	1.000
	mm/min	mm/min	mm/min	mm/min	mm/min	mm/min	mm/min	mm/min
Change point	Details	Details	Details	Details	Details	Details	Details	Details
	Channel	Channel	Channel	Channel	Channel	Channel	Channel	Channel
	Force	Force	Ext.1	Force	Force	Force	Ext.1	Force
	100	1500	0.08	0.1	100	1500	0.09	0.1
	N	N	mm	N	N	N	mm	N
Set	Set	Set	Set	Set	Set	Set	Set	
GetData	Force Ext.1	Force Ext.1	None	None	Force Ext.1	Force Ext.1	None	None
Samplings	10msec	Same as prev. area	Same as prev. area	Same as prev. area	10msec	Same as prev. area	Same as prev. area	Same as prev. area
Loop	None	None	None	None	None	None	None	None

Bauschinger Effect Measurement Jig

Measuring the Bauschinger effect is extremely useful in simulations for evaluating press workability.

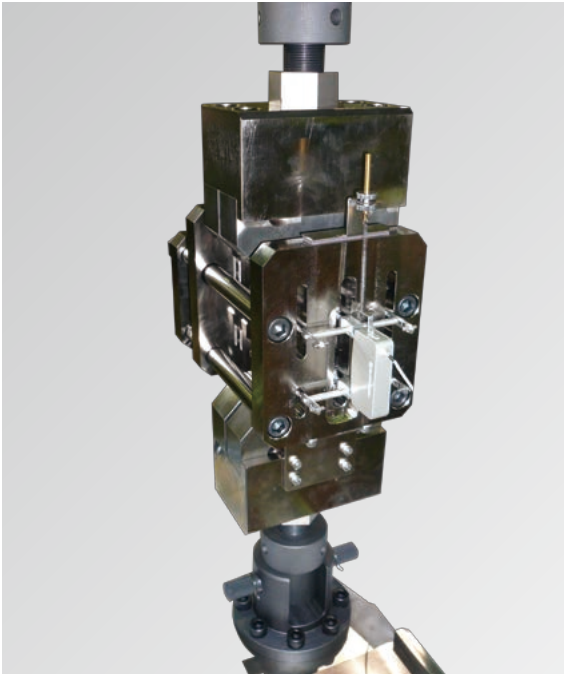

Simply attach the jig to an Autograph machine to measure Bauschinger effects.

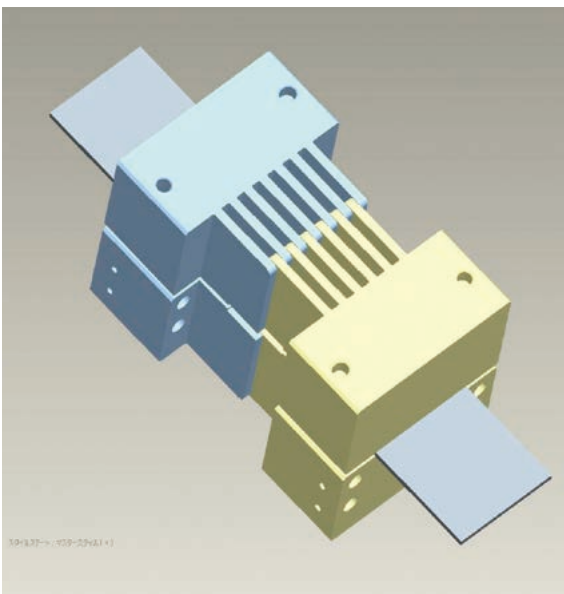

The anti-buckling guide uses comb-type teeth to allow applying large-deformation tensile-compression in-plane reversing loads.

The features of this testing jig, which includes a mechanism to prevent buckling, are listed below.

Using the Bauschinger Effect Measurement Jig

- Reduces press die development cost and time by reducing the number of required die modifications.
- Allows acquiring basic data used for simulations.
- Improves accuracy of press die simulations.
- Allows evaluating unknown materials.
- Allows performing tensile-compression reversing load tests with the actual sheet material to be used.
- Allows providing actual material characteristics as feedback to simulation.

Key Points of Shimadzu Jig

- Allow performing tests not previously possible at a reasonable cost.
- Easy to maintain
- Enable more efficient testing by removing the jig from the Autograph machine and laying it on its side for assembly.
- Grips with no slippage allow performing large-deformation reversing load tests.

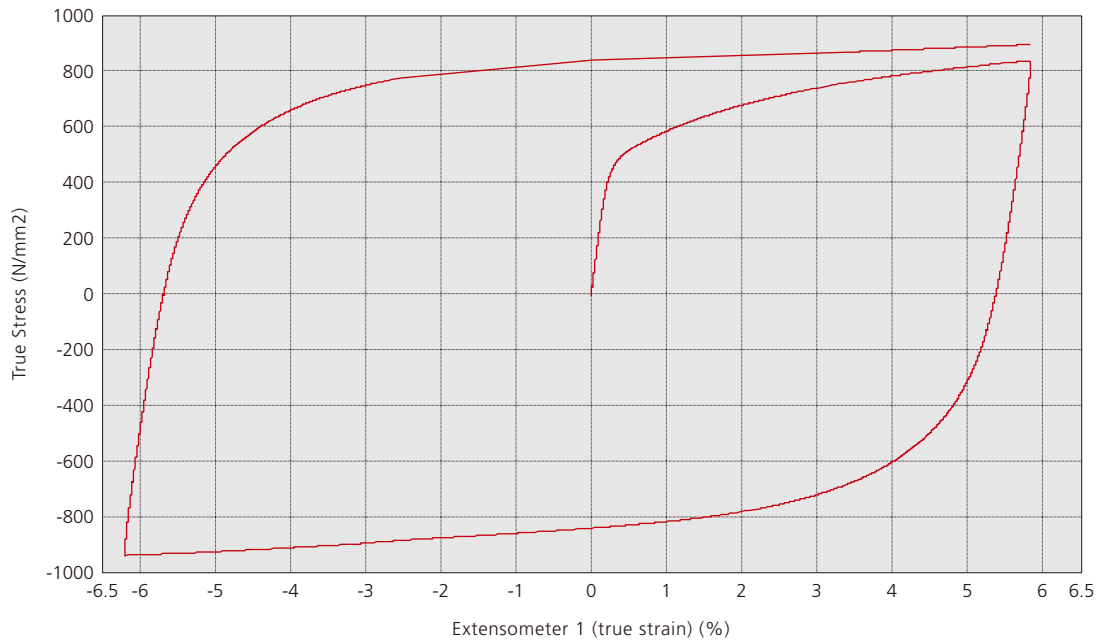

Specifications

Applicable Model		AG-100kN
Loading Capacity		100 kN tensile and 100 kN compression
Anti-Buckling Unit	Hydraulic Source	Manual hydraulic pump
	Straightening Pressure	Max. 40 kN
Elongation Measurement Device	Type	Strain gauge type
	Gauge Length	50 mm
	Measurement Range	+50 % / -10 %
	Measurement Precision	JIS B 7741 Class 1
Applicable Test Specimens	JIS No. 5	200 mm total length by 40 mm wide
		60 mm long and 25 mm wide area with parallel sides
		1 mm to 3 mm thick
	JIS Special No. 5 (wider specimen width)	200 mm total length by 45 mm wide
		60 mm long and 35 mm wide area with parallel sides
		1 mm to 3 mm thick
Operating Temperature Range		Room temperature

Biaxial Tensile Test Jig

Biaxial tensile testing helps improve the accuracy of press forming simulations by more closely approximating actual loading conditions. Previously, there was no unified standard and no commonly used evaluation method. However, with the release of ISO 16842, biaxial tensile testing methods have now been standardized globally. Standardization has provided reliable testing methods by taking into consideration the use of sample shapes that are less likely to cause interference with other axes and by specifying the location to affix strain gauges so that they reliably measure biaxial strain. The testing jig is compliant with ISO 16842 standards, enabling tests to be performed easily by simply attaching the jig to the Autograph machine.

1 Includes various convenient features.

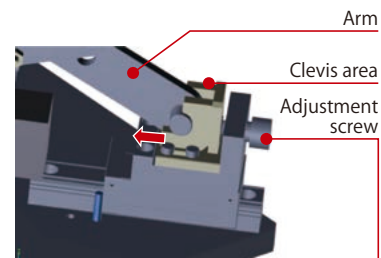
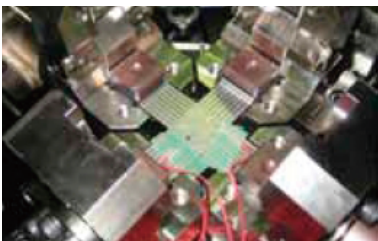
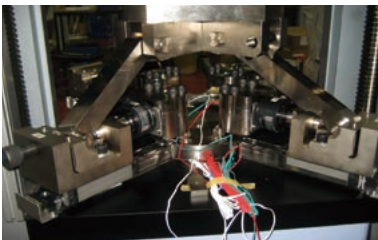

Pre-tension can be adjusted using the adjustment screw.

- The pre-tension adjustment screw allows applying an initial load with good reproducibility and simplifies the setup process.

- Enables axial tensile testing by simply setting up the jig on the Autograph machine.
- A detachable arm allows changing the tensile ratio to 1:1, 1:1.5, or 1:2.

- Tensile, compression, and bending jigs can be attached with the biaxial tensile test jig installed.

2 Compliant with ISO 16842 test standard

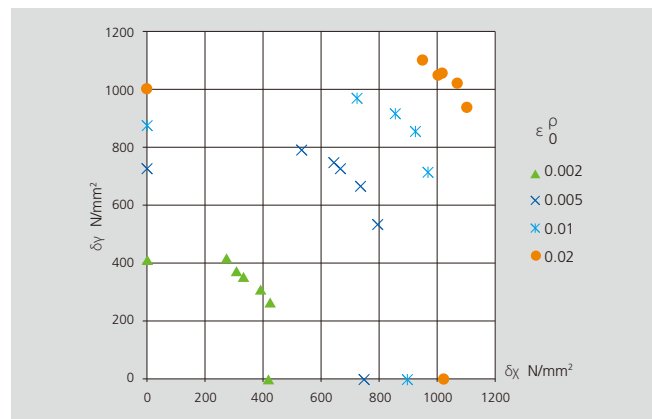
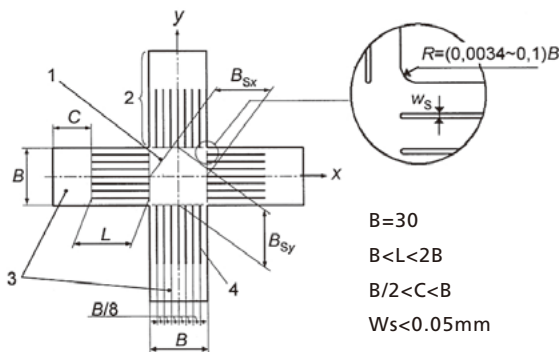

3 Benefits compared to a dedicated machine

- Machine can be acquired for a reasonable cost.
- Lack of hydraulics provides easy maintenance.
- Other tests can be performed on the same machine.

The following example shows results from using different tensile stress ratios to test high tensile steel. It shows how results change as the tensile stress ratio changes.

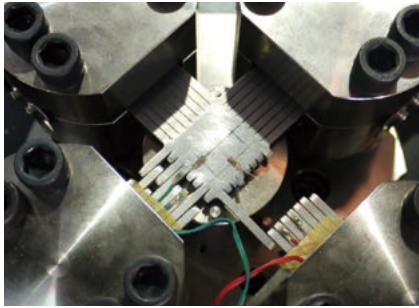

During Measurement

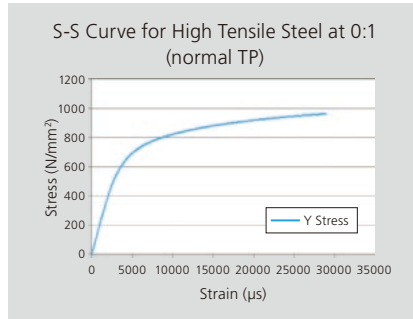

0:1 Tensile Ratio (uniaxial)

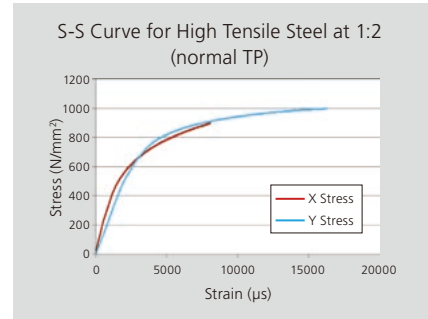

1:2 Tensile Ratio

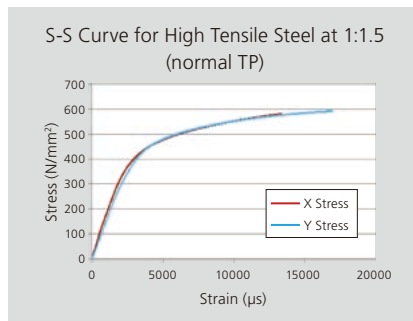

1:1.5 Tensile Ratio

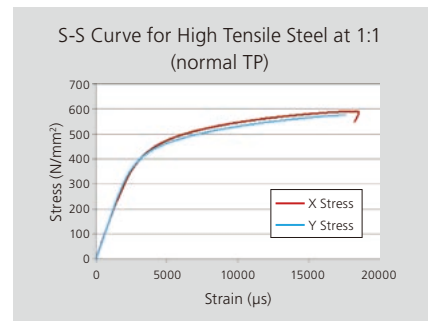

1:1 Tensile Ratio

Note: The drop in test force at the end of the X-axis for 1:1 is due to sample failure.

Biaxial Tensile Test Jig Specifications

	For AG-250/300kN	For AG-100kN
Max. Test Force	50 kN	20 kN
Test Force Precision	Class 1	
Test Force Measurement Range	1/1 to 1/50	
Applicable Test Standards	Compliant with ISO 16842 Metallic materials - Sheet and strip - Biaxial tensile testing method using a cruciform test piece	
Applicable Specimen Shapes	30 mm wide cruciform with 150, 180, or 210 mm sides (180 and 210 mm sizes are optional)	
Applicable Specimen Thicknesses	0.6 to 3.2 mm	
Biaxial Tensile Stress Ratio	1:1, 1:1.5, or 1:2	
Stroke (pulsating)	7.5 mm	
Weight	30 kg upper and 160 kg lower	

Evaluation of Die Slipperiness

Drawbead Testing System

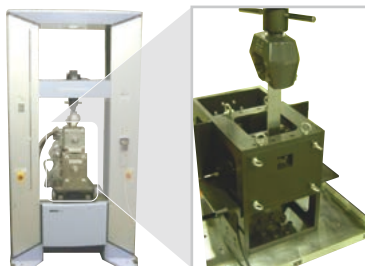

Evaluation of Drawability

Plane Deep Drawability Test

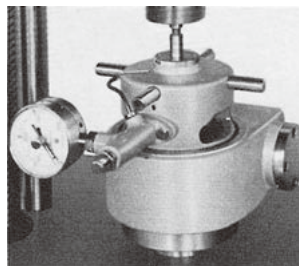

Evaluation of Work Hardening

HMV-G
Micro Vickers Hardness Tester



Related Testing and Evaluation Instruments

Autograph Precision
Universal Testing Machine
AG-X plus Series



Material Testing Operation Software
TRAPEZIUM X

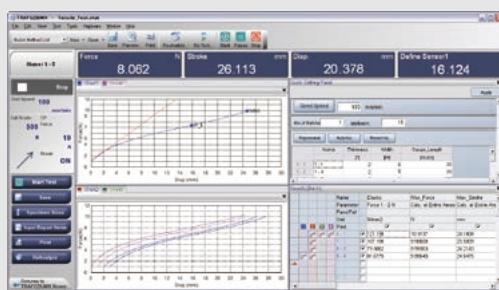

Automatic Extensometer
SIE-560/560S

