

SGP300 Series

Cast-iron body



C621-E022A

◆ Model number

SGP300 A 17 A 2 H 1 - L XXX

① ② ③ ④ ⑤ ⑥ ⑦ ⑧ ⑨

- | | | | |
|---|---|---|---|
| <p>① Series number
SGP300 series</p> <p>② Mounting spigot diameter
- : $\phi 82_{-0.090}^{+0.036}$
A : $\phi 82.55_{-0.06}^{+0.03}$</p> <p>③ Size</p> | <p>④ Position of ports
A : side ports
D : rear ports</p> <p>⑤ Port configuration
1 : flange port
2 : G screw thread</p> | <p>⑥ Mounting
H : horizontal 2 bolts</p> <p>⑦ Shaft end
1 : SAE Spline 10 teeth</p> | <p>⑧ Rotation viewing from shaft end
L = counterclockwise
R = clockwise</p> <p>⑨ Code number in 3 figures</p> |
|---|---|---|---|

◆ Specifications

Size	Displacement		Rated pressure			Max. peak pressure			Speed min ⁻¹		Inlet pressure	Mass	
	cm ³	in ³	MPa	bar	psi	MPa	bar	psi	MIN.	MAX.		kg	lb
10.5	10.4	0.634	25.0	250	3625	30.0	300	4350	500	3500	bar -0.20~ 1.0 MPa -0.02~ 0.1 psi -2.9 ~14.5	3.8	8.36
12	12.2	0.744										3.9	8.58
15	14.8	0.903										4.0	8.80
17	16.7	1.019										4.2	9.24
19	19.2	1.171										4.2	9.24
21	21.0	1.281										4.3	9.46
23	22.9	1.397	23.0	230	3335	26.4	264	3828			4.4	9.68	
24	23.6	1.440	22.0	220	3190	25.0	250	3625			4.5	9.90	

◆ Typical assembly

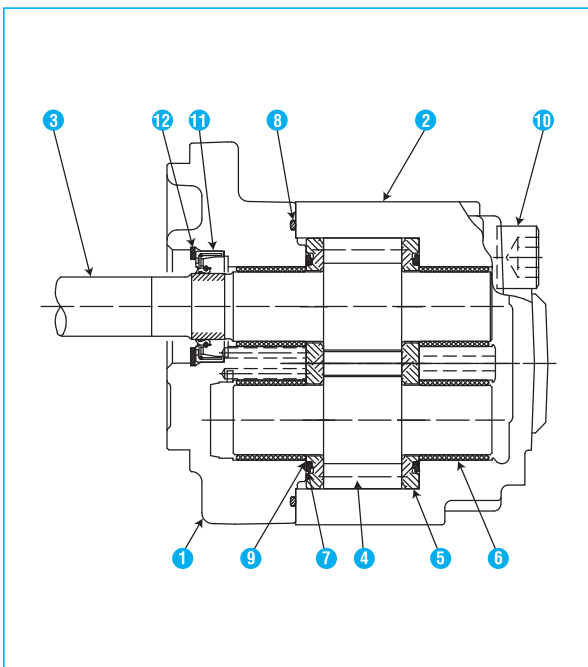

Item No.	Name	QTY	Material
①	Front cover	1	Aluminum alloy
②	Body	1	Cast iron
③	Drive gear	1	Alloy steel
④	Driven gear	1	Alloy steel
⑤	Side plate	2	Special alloy steel
⑥	Bush	4	Special alloy steel
⑦	Gasket	2	Nitrile rubber
⑧	O-ring	1	Nitrile rubber
⑨	Back-up	2	Synthetic resin
⑩	Bolt	4	Alloy steel
⑪	Oil seal	1	Nitrile rubber
⑫	Retainer ring	1	Carbon steel

NOTES : "QTY" shows the amount per one

SGP300 Series Cast-iron body

◆ Outline dimensions

dimensions in mm

SGP300- \square \square \square A2H \square -LXXX (Side ports)

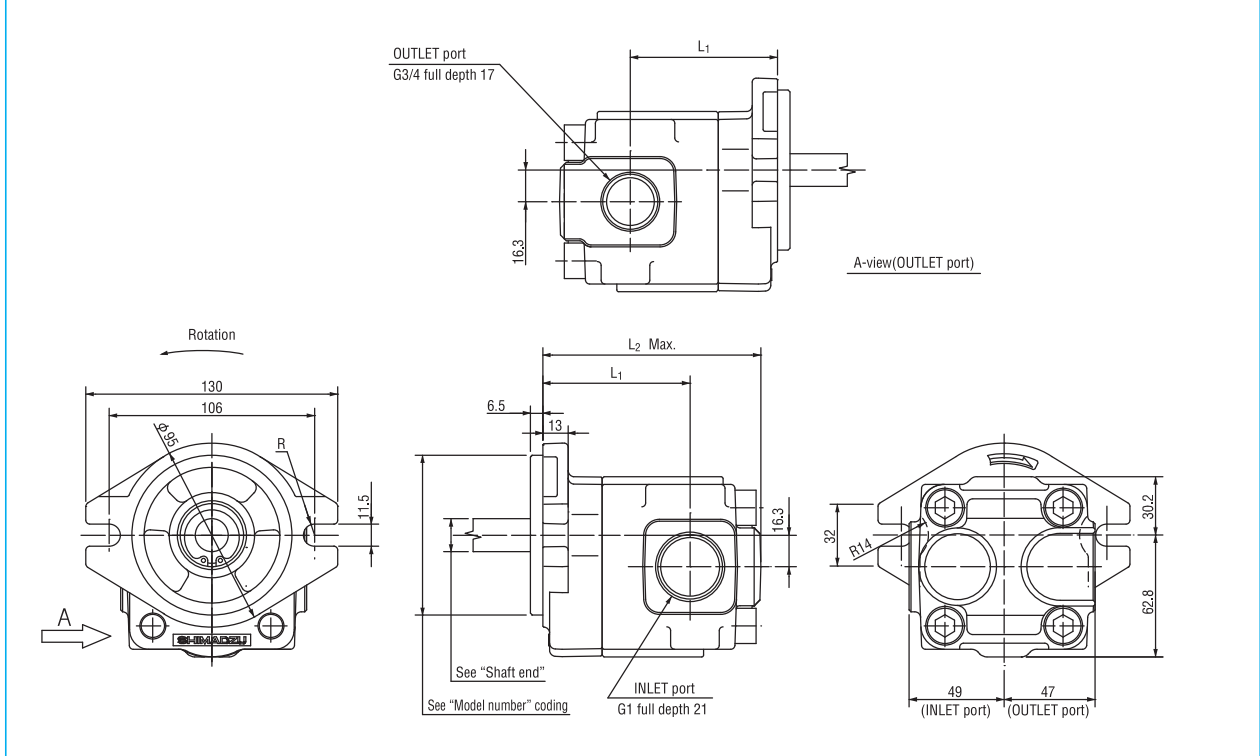

NOTE 1. Figure shown indicated counterclockwise rotation “L” viewing from shaft end. Clockwise rotation “R” is mirror image of this.

2. Unless otherwise specified, tolerance on dimension are ± 1.0 mm.

Size	L ₁	L ₂
10.5	58.0	96.5
12	60.5	99.0
15	64.0	102.5
17	66.5	105.0
19	70.0	108.5
21	72.5	111.0
23	75.0	113.5
24	76.0	114.5

● Shaft end

SAE Spline (Some dimensions are different form SAE standard.)	
SAE Spline 10 teeth	
	No. of teeth : 10
	D.P. : 16/32
	Pressure angle : 30°
	Over pin dia. : 20.263~ 20.193
	Pin dia. : φ3.048