

●形式表示例 Model number

AU **1.7** **D2075** **R** **XXX** **Q**

① ② ③ ④ ⑤ ⑥

① シリーズ名

① Series

② ポンプサイズ (cm³)
0.8, 1.7, 2.5, 3.5, 5, 7cm³

② Pump displacement (cm³)
0.8, 1.7, 2.5, 3.5, 5, 7cm³

③ モーター記号

③ Motor code

モーター記号	電圧	公称出力	種別	耐熱クラス	効率クラス
Y2040	AC200V	0.4 kW	三相誘導電動機	E	IE1
D2075		0.75kW		F	IE3
D2150		1.5 kW			
D2220		2.2 kW			

Motor code	Voltage	Nominal power	Classification	Insulation class	Efficiency class
Y2040	AC200V	0.4 kW	Three phase induction motor	E	IE1
D2075		0.75kW		F	IE3
D2150		1.5 kW			
D2220		2.2 kW			

共通仕様

- (1) 極数4極
- (2) 全閉外扇形
- (3) 屋内仕様

Common specification

- (1) Pole:4
- (2) Totally enclosed fan-cooled type
- (3) Indoor use

④ 回路記号 Circuit symbol

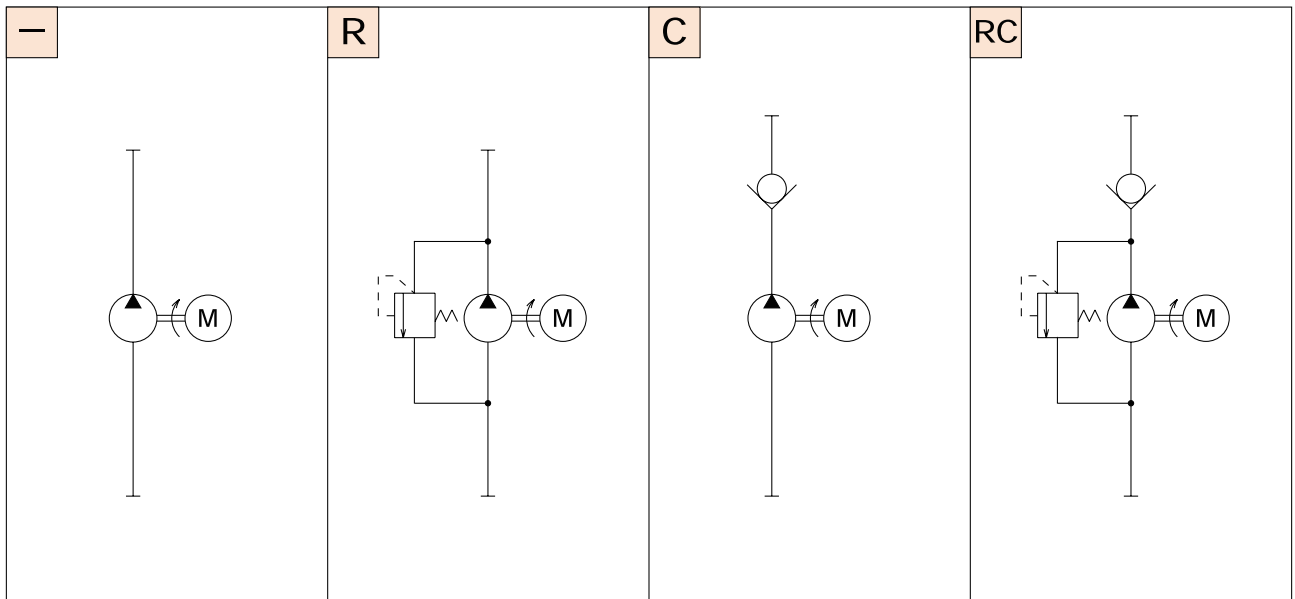

注) "R" "RC" はごくまれにリリーフ弁が作動するときに使用してください。頻繁に作動する場合は "-" を使用し、外部リリーフ弁を付けてください。

Note : Type "R" and "RC" are only available to the application in which the relief valve operates very rarely and in a short time. If frequent operation of the relief valve, use type "-" and put the relief valve externally.

⑤ コード番号

下3ケタを表示(当社にて採番)

⑤ Code number

In 3 figures given by our factory.

⑥ リリーフ圧記号

B: 2.9 (MPa) G: 7.8 (MPa) P: 12.7 (MPa) U: 17.2 (MPa)
 C: 3.9 (MPa) H: 8.8 (MPa) Q: 13.7 (MPa)
 D: 4.9 (MPa) J: 9.8 (MPa) R: 14.7 (MPa)
 E: 5.9 (MPa) L: 10.8 (MPa) S: 15.7 (MPa)
 F: 6.9 (MPa) M: 11.8 (MPa) T: 16.7 (MPa)

⑥ Relief pressure code

B: 2.9 (MPa) G: 7.8 (MPa) P: 12.7 (MPa) U: 17.2 (MPa)
 C: 3.9 (MPa) H: 8.8 (MPa) Q: 13.7 (MPa)
 D: 4.9 (MPa) J: 9.8 (MPa) R: 14.7 (MPa)
 E: 5.9 (MPa) L: 10.8 (MPa) S: 15.7 (MPa)
 F: 6.9 (MPa) M: 11.8 (MPa) T: 16.7 (MPa)

●モータとポンプの組合せ

For selection of motor, pump and its applicable pressure

(下記の圧力以下になるように組合せを選定してください。)

(Figure of pressure shown in chart below is maximum value in operation.)

パッケージ形式 Model number		AU0.8	AU1.7	AU2.5	AU3.5	AU5	AU7	
押しのけ容積 Displacement (cm ³)		0.77	1.66	2.43	3.46	4.99	7.04	
0.4kW	60Hz	圧力 Pressure (MPa)	10.3	5.9	3.3	—	—	—
		流量 Flow (ℓ/min)	1.1	2.8	4.2	—	—	—
	50Hz	圧力 Pressure (MPa)	13.1	7.4	4.3	—	—	—
		流量 Flow (ℓ/min)	0.9	2.2	3.4	—	—	—
0.75kW	60Hz	圧力 Pressure (MPa)	20.6	12.3	7.7	5.0	3.2	—
		流量 Flow (ℓ/min)	1.0	2.7	4.1	5.9	8.7	—
	50Hz	圧力 Pressure (MPa)	20.6	15.0	9.7	6.4	4.2	—
		流量 Flow (ℓ/min)	0.8	2.2	3.3	4.9	7.2	—
1.5kW	60Hz	圧力 Pressure (MPa)	20.6	20.6	17.4	11.9	8.0	5.2
		流量 Flow (ℓ/min)	1.0	2.6	4.0	5.8	8.6	12.3
	50Hz	圧力 Pressure (MPa)	20.6	20.6	20.6	14.6	10.0	6.6
		流量 Flow (ℓ/min)	0.8	2.1	3.2	4.8	7.1	10.2
2.2kW	60Hz	圧力 Pressure (MPa)	20.6	20.6	20.6	18.3	12.6	8.4
		流量 Flow (ℓ/min)	1.0	2.6	4.0	5.7	8.5	12.2
	50Hz	圧力 Pressure (MPa)	20.6	20.6	20.6	20.6	15.4	10.5
		流量 Flow (ℓ/min)	0.8	2.1	3.2	4.7	7.0	10.1

●性能曲線 Performance curves

ISO VG32 Hydraulic Fluid at 40°C

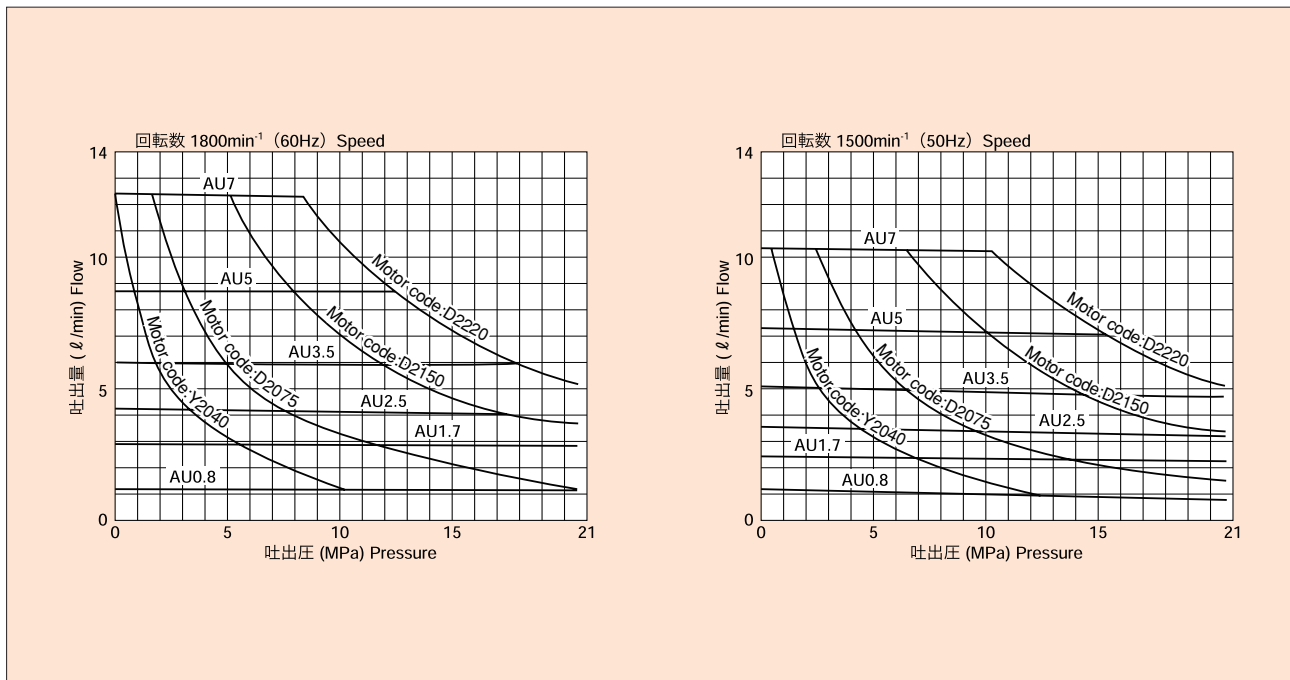

●外形図 Outline dimensions

質量はポンプサイズ「2.5」の場合を示しています。

Figures of mass correspond to 「2.5」of pump displacement.

AU□D2075

基幹形式 Model	L	吸込口 Inlet port		
		ねじ Thread	深さ Depth	適合Oリング O-Ring
AU0.8 AU1.7	77.5	G3/8 (JIS B 0202)	12 以上 Min	P14 (JIS B 2401)
AU2.5 AU3.5	83.5			
AU5	97.5			

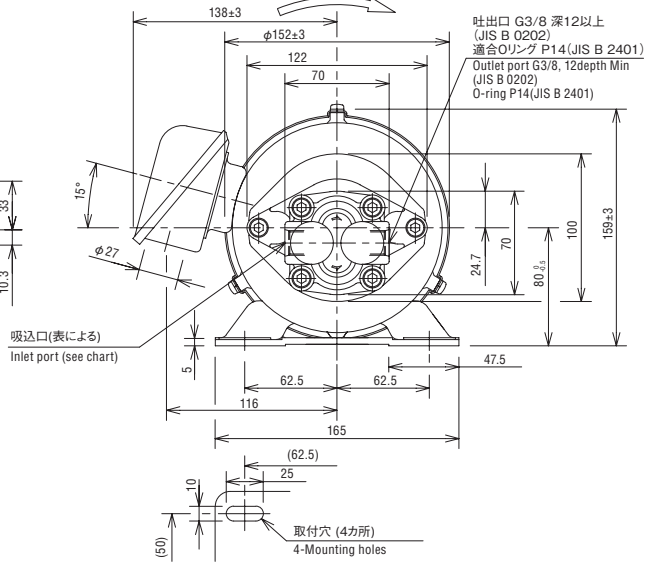
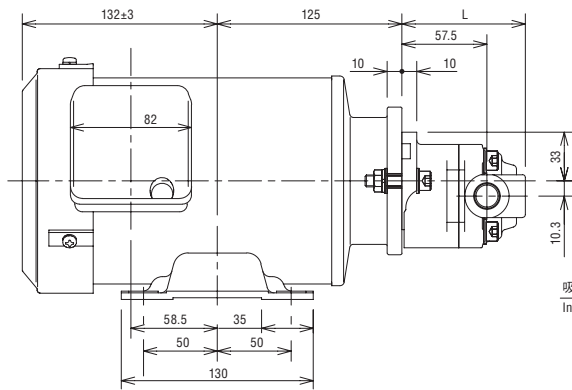
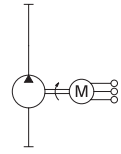

unit:mm

質量 Mass 16.9kg

AU□D2075RC

基幹形式 Model	L	吸込口 Inlet port		
		ねじ Thread	深さ Depth	適合Oリング O-Ring
AU0.8 AU1.7	77.5	G3/8 (JIS B 0202)	12 以上 Min	P14 (JIS B 2401)
AU2.5 AU3.5	83.5			
AU5	97.5			

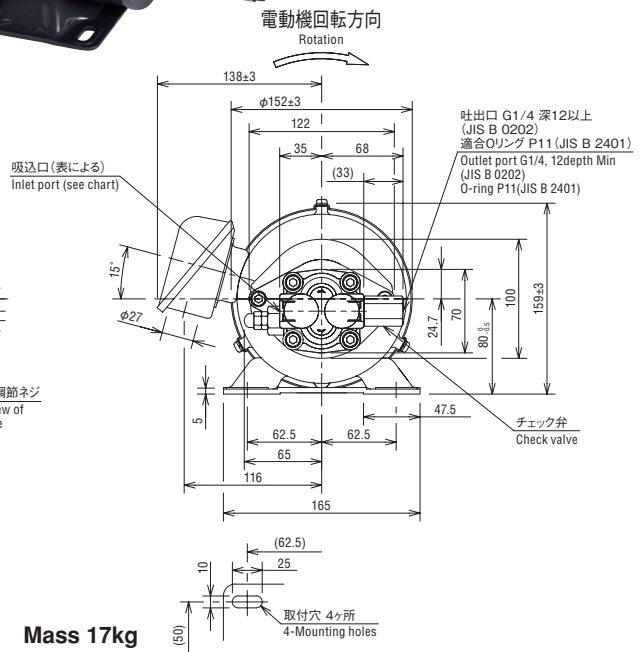
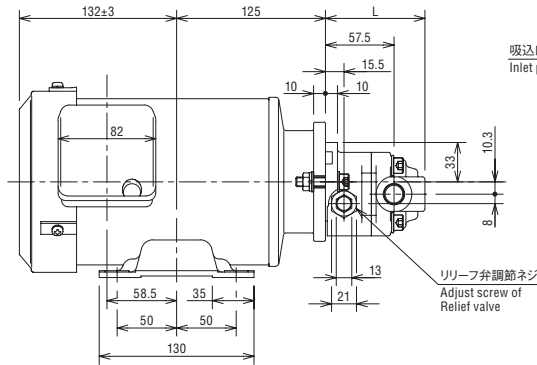
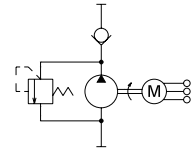

unit:mm

質量 Mass 17kg