

## To: Our Valued Customers

Shimadzu Industrial Systems Co., Ltd.

# Incident Reports and Urgent Safety Notice for Hydrogen-Operated Industrial Furnaces

---

Dear Valued Customers,

We are writing to notify you of the recent safety incidents involving the use of hydrogen gas in our industrial furnaces. We have compiled a summary of these incidents, their presumed causes, and precautionary measures requested to prevent recurrence.

Please be strongly advised that inadequate safety management can lead to catastrophic accidents, including severe instrument damage, fires, and personal injury. We strongly request that you reliably implement all necessary inspections and safety measures.

### Details

## 1. Incident Reports

### 1.1 Incident Involving Compressed Air Contamination

[Situation]

In a hydrogen-operated furnace, the chamber was evacuated and repressurized with nitrogen prior to introducing hydrogen for heat treatment. Upon starting the process, abnormal combustion occurred, causing damage to the internal carbon components.

[(Presumed) Cause]

The customer's compressed air piping and nitrogen piping were physically connected, and internal leakage occurred in a check valve and a valve installed at this connection point. Consequently, the compressed air bled into the nitrogen supply, and the oxygen concentration inside the furnace is presumed to have increased during repressurization.

[Request] (Safety Precautions)

- (1) Gas piping for nitrogen, compressed air, and hydrogen must be installed as independent lines and connected to their designated ports.**  
**—(Note) Incorrect connections or leaks can result in oxygen contamination or the formation of a flammable atmosphere, causing fire or explosion.**
- (2) Clearly label the gas type, flow direction, and operating pressure range on all gas piping, and perform periodic leak tests.**
- (3) Always perform a leak test (e.g., soap bubble test, leak detector, or pressure hold test) after gas replacement or piping modification.**
- (4) We recommend a purity of 99.99% or higher for the introduced gases.**
- (5) Please consult Shimadzu in advance if modifications to our instrument are required.**

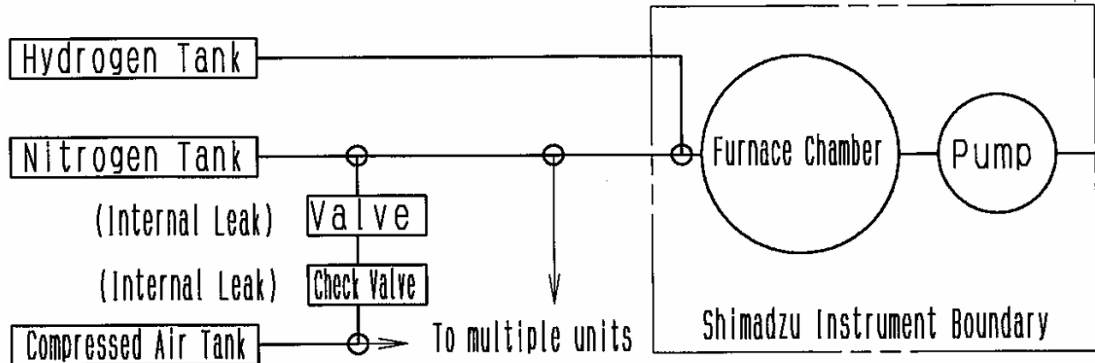

Figure 1. System Schematic at the Time of the Incident

## 1.2 Incident Potentially Linked to Instrument Relocation

[Situation]

During operation under reduced pressure in a hydrogen-operated industrial furnace, an alarm was triggered, causing the heat treatment cycle to abort. When nitrogen was subsequently introduced to purge the furnace, abnormal combustion occurred, causing damage to the internal carbon components.

[(Presumed) Cause]

An external leak was discovered at the connection point between the customer's nitrogen piping and our supply piping. When nitrogen was introduced while the system was under reduced pressure, the negative pressure generated inside the piping drew in ambient air, which is considered to be the cause. Additionally, the instrument had been relocated, reinstalled, and operated by the customer prior to this incident.

[Request] (Safety Precautions)

- (1) Please request Shimadzu to perform the relocation and reinstallation of the instrument.
- (2) After gas piping installation, always perform a leak test using methods such as a soap bubble test, a leak detector, or a pressure hold test.
- (3) Establish and execute a periodic leak inspection and maintenance plan.

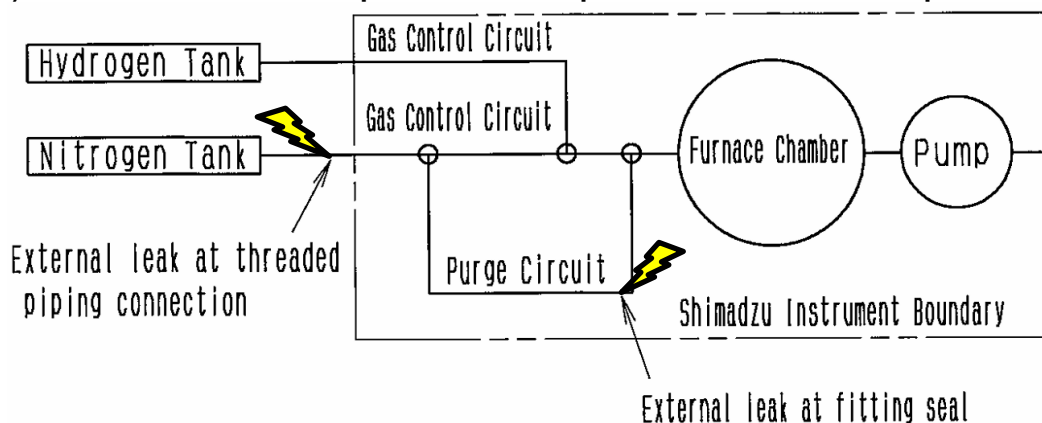

Figure 2. System Schematic at the Time of the Incident

## 2. Request for Instrument Inspection

These incidents show that insufficient safety management can result in critical hazards to both personnel and property. We urgently request that you conduct a comprehensive safety inspection of your systems.

**If it is difficult to perform these inspections at your facility, please contact Shimadzu. We will provide a separate quotation for inspection services and any necessary component replacements.**