

# Safety, Environmental, and Regulatory Information For Medical Device and Performance information

## Index (Product name)

- X-RAY TV SYSTEM SONIALVISION G4
- Digital Angiography System Trinias
- RADspeed Pro
- X-ray tube assembly 0.2/0.8P38C-85
- X-ray tube assembly 0.3/0.8P18DK-85
- X-ray tube assembly 0.6/1.2P13DK-85
- X-ray tube assembly 0.6/1.2P33DK-85
- X-ray tube assembly 0.6/1.2P18DE-85
- X-ray tube assembly 0.6/1.2P38DE-85
- X-ray tube assembly 1/2P13DK-85
- X-ray tube assembly 1/2P33D-85
- X-ray tube assembly 1/2P18DK-85
- X-ray tube assembly 1/2P38D-85
- X-ray tube assembly 0.3/0.8P323DK-85
- X-ray tube assembly 0.6/1.2P123DK-85
- X-ray tube assembly 0.6/1.2P323DK-85
- X-ray tube assembly 0.8P323DK-85
- X-ray tube assembly 0.2/0.8P39CK-85
- X-ray tube assembly 0.3/0.8P324DK-85
- X-ray tube assembly 0.6/1.2P324DK-85
- X-ray tube assembly 0.6/1.2P164DK-85
- X-ray tube assembly 0.6/1.2P364DK-85
- X-ray tube assembly 0.6/1.2P324DK-125
- X-ray tube assembly 0.6/1.2P364DK-125
- X-ray tube assembly 0.8P324DK-85
- X-ray tube assembly 0.4/0.7JG326D-265
- X-ray tube assembly 0.7/1.2JG326D-265
- X-RAY HIGH VOLTAGE GENERATOR UD150B-40
- X-RAY HIGH VOLTAGE GENERATOR UD150V-40
- X-RAY HIGH VOLTAGE GENERATOR UD150L-40
- X-RAY HIGH VOLTAGE GENERATOR UD150L-40F
- X-RAY HIGH VOLTAGE GENERATOR UD150L-40E
- X-ray radiography table BK-12HK
- X-ray radiography table BK-120MK
- X-Ray Radiography Table BK-200
- X-RAY RADIOGRAPHY STAND BR-120
- X-ray Radiography Stand BR-120T
- X-RAY RADIOGRAPHY STAND BR-120M
- X-RAY TUBE STAND FH-20HR
- X-RAY TUBE STAND FH-21HR
- Ceiling Type X-ray Tube Support CH-200M
- CEILING TYPE X-RAY TUBE SUPPORT CH-200
- COLLIMATOR TYPE R-300
- Collimator Type R-20J
- Radiography System RADspeed fit
- GENERAL RADIOGRAPHIC SYSTEM EZy-Rad Pro
- Mobile X-ray System MUX-10
- Mobile X-ray System MobileDaRt Evolution
- Mobile X-ray System MobileArt Evolution
- FDR Visionary Suite
- Mobile X-ray System FDR Go
- Mobile X-ray System Mobirex i9
- SURGICAL MOBILE C-ARM IMAGING SYSTEM OPESCOPE ACTENO
- REMOTE-CONTROLLED R/F SYSTEM FLEXAVISION
- X-RAY R/F SYSTEM FLUOROsPEED
- X-ray tube assembly 1.2U161CS-31
- X-ray tube assembly 0.7U161CS-36
- X-ray tube assembly 0.7U163CS-36
- X-ray tube assembly 0.7/1.3U163C-36
- X-ray tube assembly 0.6/1J327C-280
- X-ray tube assembly 0.6/1J317C-282
- X-ray tube assembly 0.6/1J317C-285
- X-ray tube assembly 0.6/1.2P326D-150
- X-ray tube assembly 0.6/1.2P366D-150

- English -

## Safety, Environmental, and Regulatory Information For Medical Device

### General

#### Introduction

This booklet contains the essential information about the safety instructions and precautions to ensure safe operation of the instrument. For details, please refer to the instruction manuals for the product.

Read this booklet thoroughly before using the product and operate the product in accordance with the instructions in the manuals.

#### IMPORTANT

- If the user or usage location changes, ensure that this booklet is always kept together with the product.
- If this booklet, manual or a product warning label is lost or damaged, immediately contact your Shimadzu representative to request a replacement.
- To ensure safe operation, read all safety instructions before using the product.
- To ensure safe operation, contact your Shimadzu representative if product installation, adjustment, re-installation (after the product is moved), or repair is required.

#### Notice

- Information in this booklet is subject to change without notice and does not represent a commitment on the part of the vendor.
- Any errors or omissions which may have occurred in this booklet despite the utmost care taken in its production will be corrected as soon as possible.
- All rights are reserved, including those to reproduce this booklet or parts thereof in any form without permission in writing from Shimadzu Corporation.
- The original version is approved in English.

© 2013 Shimadzu Corporation. All rights reserved.





#### IMPORTANT

#### “Operating Precautions for Safety in the Use of Electric Medical Equipment”





1. Only a technician who takes training for operating the equipment should operate the equipment,
2. When installing the equipment, pay attention to the following items:
  - (1) Do not install system near water faucet or similar equipment.
  - (2) Install it away from potential sources of problems such as abnormal pressure, temperature or humidity, drafts, direct sunlight, dust chlorine or sulfur gas.
  - (3) During transportation and operation of the equipment, avoid tilting, vibration and any impact.
  - (4) Keep the equipment away from the areas where chemicals or gases are stored.
  - (5) Use only the correct electrical power source with matching frequency, voltage and current (or wattage).
  - (6) Check the condition of the battery power source (power and polarity) before operating the equipment.
  - (7) Properly ground the equipment
3. Before operating the equipment, pay attention to the following items:
  - (1) Check the conditions of switch contacts, polarity, dial settings, and meters, and make sure the equipment performs correctly.
  - (2) Conform that the ground is connected properly.
  - (3) Check all wiring for proper and correct connections.
  - (4) Pay attention when using more than one unit at a time, because it may lead to an incorrect diagnosis and cause complications.
  - (5) Check the condition of the external electric circuit, which will be directly connected to a patient.
  - (6) Check the condition of the battery power source.
4. While operating the equipment, pay attention to the following items:
  - (1) Do not over-exceed time or the amount of equipment use needed for diagnosis or therapy.
  - (2) Observe the equipment and patient continuously for early detection of problems.
  - (3) When a problem is detected with the equipment, take proper action to stop the equipment without harming the patient.
  - (4) Do not let the equipment touch the patient.
5. After operating the equipment, pay attention to the following items:
  - (1) Turn off the switches and return the dial to their original before use in the prescribed order. Then, turn off the main power switch.
  - (2) Do not pull the power cable forcibly from the outlet.

- (3) When storing the equipment, pay attention to the following factors:
  - (i) Keep it away from the water.
  - (ii) Store it away from the potential causes of problems such as abnormal pressure, temperature or humidity, draft, direct sunlight, dust chlorine or sulfur gas.
  - (iii) Avoid tilting, vibration and any impact when storing.
  - (iv) Store the equipment away from areas where chemicals and gases are stored.
- (4) Clean all attachments, cables and contacts, and store them in one place.
- (5) Keep the equipment clean to avoid problems during the next use.
6. When the equipment is found to be out of order, do not try to repair it. Immediately call a certified repair technician for repair.
7. Do not modify and part of the equipment.
8. Preventive maintenance
  - (1) The equipment and its parts should be periodically checked.
  - (2) If the equipment has not been in operation for an extended period of time, test it prior to actual operation to make sure it works correctly and safety.
9. Operate properly according to the operating manual.

### **Indications Used in This Booklet**

Mark	Description
 <b>DANGER</b>	States a direct danger that may cause death or serious injury if it is not avoided.
 <b>WARNING</b>	States an indirect or potential danger that may cause death or serious injury if it is not avoided.
 <b>CAUTION</b>	States a danger that may cause slight or medium injury or may cause damage in equipment or fire if it is not avoided.
 <b>NOTE</b>	States information which helps to use the system correctly.

### **Warning Labels**

Symbol	Application	Symbol	Application
	Refer to the Instruction Manual when handling or operating any section marked with this symbol.		Indicates that some parts will reach high temperatures.
	Indicates that lethal voltage is present.		Indicates that the equipment emits ionizing radiation (X-rays).

### **Action for Environment (WEEE)**

**To all users of Shimadzu equipment in the European Union:**

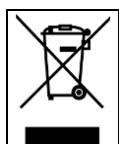

**WEEE Mark**

Equipment marked with this symbol indicates that it was sold on or after 13th August 2005, which means it should not be disposed of with general household waste. Note that our equipment is for industrial/professional use only.

**Contact Shimadzu service representative when the equipment has reached the end of its life. They will advise you regarding the equipment take-back.**

With your co-operation we are aiming to reduce contamination from waste electronic and electrical equipment and preserve natural resource through re-use and recycling.

Do not hesitate to ask Shimadzu service representative, if you require further information.

**- English -**

## ***Regulatory Information***

---

For Europe:

The product complies with the following requirements.

Medical Device Regulation, RoHS Directive



Manufacturer	Shimadzu Corporation
Address	1, Nishinokyo Kuwabara-cho, Nakagyo-ku, Kyoto 604-8511, Japan
Authorized Representative in EU	SHIMADZU EUROPA GmbH
Address	Albert-Hahn-Strasse 6-10, 47269 Duisburg, Germany

## X-RAY TV SYSTEM SONIALVISION G4

### Precautions in Usage

 **WARNING**

 **The responsibility for management of use and maintenance of medical equipment lies with the user.**  
This equipment is restricted to use by, or under supervision of, a diagnostic radiology technician or a person with a certificate indicating equal proficiency. Repair and inspection of the inside of the equipment is dangerous. Be sure to contact your Shimadzu service representative for repair and inspection.

Instructions

 **Never modify the equipment.**  
In general, modifications are strictly prohibited by the Regulatory requirements of the law of the country where the device is installed. Please contact your Shimadzu service representative if it is necessary to modify the equipment.

Prohibitions

 **Perform periodic inspection.**  
Preventive maintenance is required to maintain long-term safety and performance of the equipment. The "6 Maintenance" chapter in this manual gives detailed descriptions of daily and periodic maintenance and inspection that a user should perform.  
As for the maintenance and inspection that only specially trained experts can perform, utilize the maintenance agreement program offered by Shimadzu.

Instructions

 **Repair and maintenance of the inside of the equipment can only be performed by engineers assigned by Shimadzu.**  
Maintenance must be assigned to specially trained experts. Contact your Shimadzu service representative for repair and maintenance.

Instructions

 **In order to ensure safety when using the system, read the operation manual provided with each system component for details on usage and relevant precautions.**

Instructions

 **CAUTION**

 **If the operator has no experience in operating the equipment, be sure that he or she receives instruction on how to operate it from Shimadzu service personnel or someone who has adequate experience in using the equipment.**  
In order to operate the equipment safely, an explanation of the operation needs to be given. When installing the equipment, Shimadzu service personnel explain the operating procedure using this instruction manual. Follow their directions and operate the equipment correctly.

Instructions

 **Secure the means for the operator and the patient to communicate with each other.**  
If equipment usage is deemed to put the patient at risk due to his or her condition, refrain from conducting the study or treatment.

Instructions

### Be Sure to Read the Following to Prevent Explosion, Electric Shock, or Injury

 **DANGER**

 **Do NOT use any potentially flammable or explosive gas, such as disinfectant sprays, near the equipment.**  
Use of such gas may cause an explosion.

Prohibitions



Instructions

**Check the condition of the patient before conducting a study.**

If equipment usage is deemed to put the patient at risk due to the his or her condition, refrain from conducting the study or treatment.



Prohibitions

**Do NOT use the equipment in places where liquid may enter.**

The equipment is not designed to be waterproof. Invasion of any liquid should cause electric shock, system failure or malfunction.



Prohibitions

**Do NOT spill any liquid, such as contrast medium, saline, or disinfectant, onto the equipment.**

Should such liquid drip on equipment surfaces, wipe it off immediately. Any such liquid entering into system electronics may cause failure or malfunction.

Should liquid drip on the equipment or enter the covers, immediately turn off the power and contact your Shimadzu service representative.



Instructions

**If an abnormality occurs during operation, or if an unusual odor or smoke emitted during operation, stop using the equipment immediately and contact your Shimadzu service representative.**

Continued use may damage the equipment and cause injury.



Prohibitions

**Do NOT open the covers of the equipment.**

Otherwise, electric shock may result. When opening the covers for maintenance, contact your Shimadzu service representative.



Prohibitions

**Do NOT use in a location where metal fragments may enter the equipment.**

This can result in electric shocks.



Instructions

**Always be very careful when moving the table top to avoid contact with the patient or operator and to ensure that the patient or operator does not become caught between the equipment and any neighboring devices.**

Otherwise, it may cause injury.



Instructions

**Patients who have difficulty with physical activity must be assisted by a caregiver.**

When a caregiver assists a patient, the operator must ensure the safety of the caregiver as the patient to operate the equipment.



Prohibitions

**Do NOT perform any maintenance work on any part of the equipment during clinical use.**

The patient may be injured.

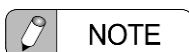



If the following happens, turn the power off and then restart the equipment.

- The X-ray diagnostic table does not function properly but an error message is not displayed, even after operating the table.
- X-rays are not irradiated but an error message is not displayed, even after performing fluoroscopy or radiography operations.
- The digital radiography unit and touch panel cannot be operated or do not respond even if operated.

The values displayed on this equipment may include a margin of error as stipulated in the applicable standards.

## Cautions on Environmental Conditions

 **WARNING**



Prohibitions

**Do NOT use the equipment in an oxygen-rich environment.**

Using the equipment in an oxygen-rich environment may cause fire, which may lead to fatal or serious injuries to the patient or damage to the equipment.



Prohibitions

**Do NOT connect the equipment other than the designated equipment to the system.**

 **CAUTION**



Instructions

**Be sure to use the equipment under the following environmental conditions:**

The installation of a dedicated air-conditioner is recommended if the building air-conditioner cannot maintain the necessary environmental conditions 24 hours a day.

- Examination room
 

Atmosphere:	No explosive gas, highly concentrated oxygen, nor corrosive gas in the atmosphere
Temperature:	10 to 30 °C
Relative humidity:	15 to 75 % (no condensation)
Atmospheric pressure:	800 to 1060 hPa
- Operation room
 

Atmosphere:	No explosive gas, highly concentrated oxygen, nor corrosive gas in the atmosphere
Temperature:	10 to 30 °C
Relative humidity:	20 to 70 % (no condensation)
Atmospheric pressure:	800 to 1060 hPa
Environment luminosity:	150 to 500 lx
Ambient noise level:	70 dB max.

There must be no sudden changes in temperature or humidity. This could cause condensation, which may lead to equipment malfunction.



Instructions

**Ground the equipment using ground wires.**

Be sure to carry out grounding according to the installation manual to reduce the danger of electric shock.



Instructions

**Before using the equipment, ensure correct operations of switches and meters as well as proper connections of high-voltage cables, cords, and ground wires.**



Prohibitions









**Do NOT disconnect cords, cables and other connections, unless it is required.**









Instructions

**Contact your Shimadzu service representative for installation and relocation of the equipment.**

**- English -****Cautions on Radiography**

 <b>WARNING</b>	
 Instructions	<p><b>Restrict all persons other than the patient from accessing the equipment in accordance with local regulations.</b></p> <p>To avoid unnecessary exposure, acceptable distances (maximum access values) to the equipment by any person other than the patient are defined for each region.</p>
 Instructions	<p><b>The equipment can be operated only by qualified personnel, such as radiology technicians or those with equivalent qualifications.</b></p>
 Prohibitions	<p><b>No person but the patient is allowed to stay in the examination room during X-ray irradiation.</b></p> <p>If the equipment is not used correctly, the operator, the patient, and other persons may receive a greater dose of radiation than necessary. If for some reason another person has to be in the examination room, that person must take adequate measures to protect themselves against radiation (protective apron, screen, etc.).</p> <p>During X-ray irradiation, the alarm sounds, and  lights up and is displayed on the acquisition monitor.</p>
 Instructions	<p><b>Perform X-ray irradiation carefully and according to the doctor's directions when using the equipment with expectant mothers, women who suspect they are pregnant, lactating women, or children.</b></p> <p>Particular ways of using the equipment may increase the scatter dose absorbed into the patient, which may cause a radiation hazard.</p>
 Instructions	<p><b>During X-ray irradiation, ensure that the X-rays irradiate the necessary region only.</b></p> <p>To avoid unnecessary exposure, narrow down the collimator and take protection measures, such as wearing a protective apron.</p>
 Prohibitions	<p><b>Do NOT place unnecessary objects in the area of X-ray exposure.</b></p> <p>Doing so might subject the patient to unnecessary exposure.</p>

 <b>CAUTION</b>	
 Instructions	<p><b>Be sure to carry out a warm-up (running-in operation of the X-ray tube unit) before taking an X-ray radiograph.</b></p>
 Instructions	<p><b>Perform the warm-up if an arc occurs.</b></p> <p>Suddenly using the X-ray tube unit near the nominal X-ray tube voltage (above 100 kV) after using the unit at a relatively low tube voltage (80 kV max.) for a prolonged period may result in arc. This arc occurs due to loss of the warm-up effect at high tube voltage after the X-ray tube unit is used at a relatively low tube voltage for a prolonged period.</p> <p>In this case, warm-up the X-ray tube unit by referring to the procedure described in the X-ray high voltage generator operation manual.</p>
 Prohibitions	<p><b>Do NOT perform unnecessary preparation for radiography.</b></p> <p>If radiography has not been performed for long with  (Ready for radiography) lit on the console, wire disconnection or withstand voltage failure may occur due to the evaporation of the X-ray tube filament.</p>
 Instructions	<p><b>In order to minimize the radiation dose on the patient, make the distance between the focus and the patient's body surface as long as possible (Minimum 45 cm).</b></p> <p>The shorter the distance becomes, the greater the amount of scatter dose absorbed into the patient, which may cause a radiation hazard.</p>

 CAUTION



**Pay extra attention when irradiating X-rays for a long time or repeatedly.**  
It may cause a radiation hazard.

Instructions



**Hold down the exposure start switch or hand switch until the exposure is complete.**  
If the switch is released partway through, X-ray irradiation is aborted at that point and an appropriate radiograph may not be taken.

Instructions

## System Operation

 WARNING



**Confirm that there is no apparatus within the operating range when moving the X-ray diagnostic table.**  
Ensure that no desk, chair, stretcher, foot switch, monitor suspension, etc. is placed within the operating range.  
The apparatus may be crushed by or collide with the equipment, causing damage.

Instructions

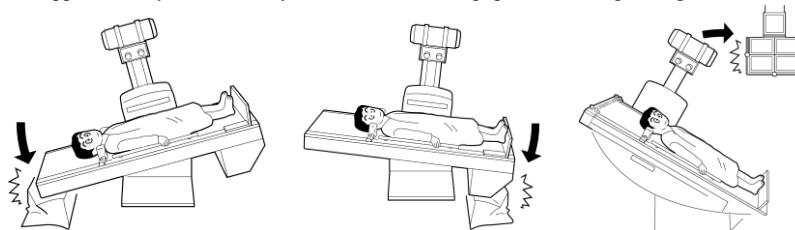

**Ensure that no one is under the X-ray diagnostic table.**  
The person may become caught under the table and injured.

Instructions



**Do NOT put your hand or fingers between the tabletop and the main frame when moving the tabletop.**  
Otherwise your hand could get caught and injured.

Prohibitions

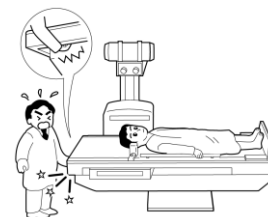



**Do NOT put your hand between the tabletop and the main frame when moving the imaging unit.**  
Otherwise your hand could get caught and injured.

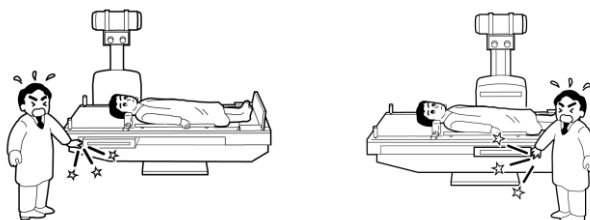

Prohibitions



**WARNING**

**Instructions**  **Ensure that the patient does not put his or her hand between the tabletop and the imaging unit when moving the imaging unit.**  
Otherwise his or her hand could get caught and injured.

**Instructions**  **Instruct the patient to hold the hand grips when he or she is placed on the tabletop.**  
Instruct the patient to hold the hand grips firmly. Insufficient holding could cause the patient to fall off the tabletop and be injured.

**Instructions**  **Ensure the safety of the patient when using squeeze compression.**  
Squeeze compression could fracture the patient's ribs if not performed correctly. After squeeze compression, press the  (squeeze compression) button to turn it off. If the imaging unit or tabletop is moved while the compression cone is operating, the compression cone may collide with the shoulder rests or foot rest and could be damaged.

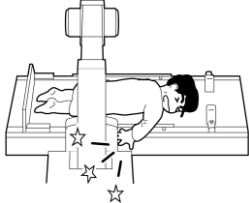
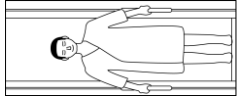
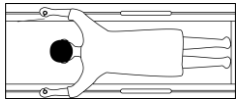





**CAUTION**

**Instructions**  **Before using the equipment, check the settings on the control device and ensure that the exposure conditions for fluoroscopy or radiography is correctly set.**

**Prohibitions**  **Do NOT place anything on the console.**  
The equipment may unintentionally be activated if anything hits the operation lever.

**Prohibitions**  **Do NOT place anything on the control cabinet.**  
The internal equipment may be damaged if anything falls into the control cabinet ventilation opening.

**Prohibitions**  **Do NOT allow a stretcher to collide against the front cover of the X-ray diagnostic table.**  
Doing so may damage the front cover.

**Instructions**  **After using the equipment, open the circuit breaker to which the power cord of the high-voltage generator is connected to ensure safety.**

**Instructions**  **It is recommended to keep backup X-ray equipment in case the equipment fails to operate due to a fault.**

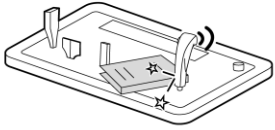

## Cautions on the LCD Monitor

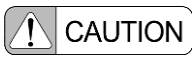

 **Do NOT leave rubber or vinyl products in contact with the LCD monitor for long periods.**  
This could cause decomposition, or peeling of the coating.

Prohibitions

 **Do NOT scratch or hit the LCD monitor surface with a hard material, such as a ballpoint pen.**  
Otherwise, the LCD monitor surface may be damaged.

Prohibitions

 **Do NOT push hard on the LCD monitor surface.**  
It may cause an uneven image, leading to the monitor's failure.

Prohibitions

## Accessories and Options



 **Do NOT place the foot switch or the foot controller under the X-ray diagnostic table.**  
The operator's foot may get caught under the X-ray diagnostic table and injured.

Prohibitions

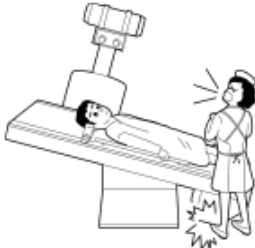



 **Do NOT place anything on the foot switch. Pay extra attention not to step on the foot switch accidentally.**  
Unintended X-rays may be radiated.

Prohibitions

 **Do NOT place the foot switch or the foot controller in the operating range of the X-ray diagnostic table when it is not used in order to prevent accidental operation.**  
The X-ray diagnostic table may unintentionally move or X-rays may unintentionally be radiated.

Prohibitions

 **WARNING**

  
 Instructions

**Hold the patient securely so that the patient does not fall from the table. Particularly when tilting the tabletop downward, confirm the patient's safety and operate carefully.**

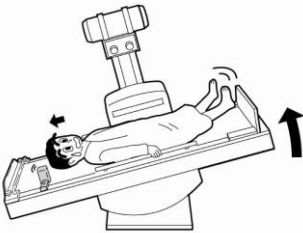

**Attach appropriate accessories according to the patient's body and body position to hold the patient.**

**Foot rest:** Use to keep a patient's foot position when tilting the tabletop.

**Shoulder rests:** Use to prevent a patient from slipping down to the head side when tilting the tabletop downward.

**Hand grips:** Use to hold and change the patient's position when the tabletop is moving laterally or tilted.

After attaching accessories, push and pull them in all directions to ensure that they are secured to the equipment firmly to hold the patient's load. Otherwise the patient may fall off and be injured when tilting the tabletop or changing body position.

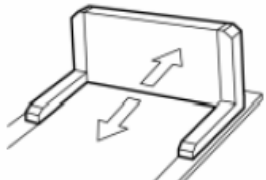
  
 Attaching the foot rest

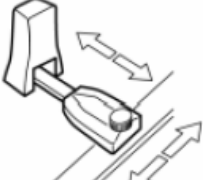
  
 Attaching a shoulder rest

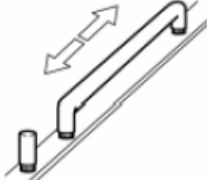
  
 Attaching a hand grip

  
 Prohibitions

**Do NOT support the patient's body weight only with the shoulder rests, hand grips or upper hand grip.**  
Tilting the tabletop could cause the patient to fall off the tabletop and be injured.

  
 Instructions

**Completely fasten the compression band to the tabletop.**  
If not fastened firmly, the compression band may come off or the lever may fall over, which could cause injury.

  
 Instructions

**Gradually tighten the compression band while checking the patient's condition.**  
Rapid tightening could cause bone fractures.

  
 Prohibitions

**Do NOT support the patient's body weight only with the compression band.**  
Tilting the tabletop could cause the patient to fall off the tabletop and be injured.

 **WARNING**

 **Be careful of the motion of the X-ray diagnostic table while operating the local console.**  
When moving or tilting the imaging unit in the vertical position, the X-ray tube unit may hit and injure the operator's head.

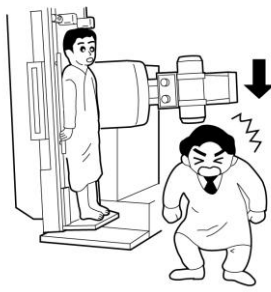



 **CAUTION**

 **Do NOT use the local console or monitor cart on a floor that is tilted more than 5°.**  
This could cause the local console or monitor cart to fall over.

 **Do NOT move the local console or monitor cart while their casters are locked.**  
This could cause the local console or monitor cart to fall over.

 **Move the local console or monitor cart by holding the handle, being careful about bumps and cables on the floor.**  
This could cause the local console or monitor cart to fall over.



 **Watch out for the cable of the local console or monitor cart.**  
If you catch the cable with your foot the local console or monitor cart could fall over.

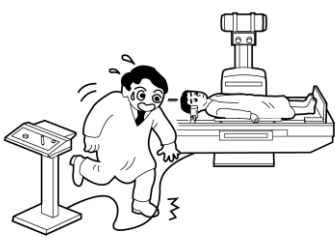

 **Do NOT subject the grid to any force from above while it is pulled out.**  
Doing so could damage it.

 **To mount or remove the X-ray grid, move the tabletop all the way back and lift the hand guard.**  
If you do it without moving the tabletop all the way back, you may get your fingers caught between the tabletop and the grid.  
If you do it without lifting the hand guard, your fingers may be injured by the hand guard.

- English -

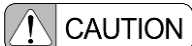



Instructions

**When holding the grid handle, take care not to allow your fingers to protrude from the grid.**  
Your fingers might get nipped between the unit and the grid.

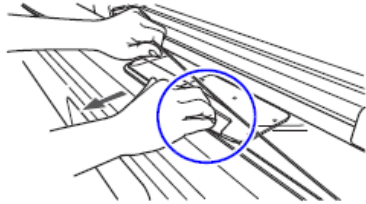

How to hold the handle –  
Good example



How to hold the handle –  
Bad example



Instructions

**Make sure not to allow anyone to control the unit while you are mounting or demounting the X-ray grid.**  
If someone moves the tabletop, you may get the finger caught between the tabletop and the grid.



Instructions

**When not connecting the rotary foot rest and the X-ray diagnostic table with a curl cord, be sure to attach the dust cap to the connection parts.**  
The equipment may be damaged if foreign matter enters it.

### Digital Radiography Unit





Prohibitions

**Do NOT install any other software on the computer.**  
The system may not run due to changes to the operating system or conflicting drivers. The warranty will be invalidated if any other software is installed.

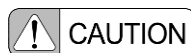

Instructions

**Observe the following precautions:**

- Do NOT attempt to alter any system software.  
Doing so could disrupt the functioning of the system and result in loss of images.
- Do NOT attempt to alter any system hardware components.  
Doing so could disrupt the functioning of the system and result in loss of images. Use of any hardware components not provided by Shimadzu is strictly prohibited. This includes peripherals (mouse, keyboard, monitor, etc.).
- Pay careful attention to other high frequency-generating equipment in the room. The PC cabinet should be as far as possible from any such device to prevent noise from affecting the image video signal.
- Do NOT disconnect the cables connected to this system.  
Otherwise the image may not be displayed, the data may be damaged and the system may fail to start up.
- A system hardware failure may delete images archived in the hard disk. Shimadzu is not responsible for the images in this case.
- Do NOT move any system component.  
If necessary, move it carefully to avoid damage.
- Do NOT connect the system to the Internet.  
Shimadzu accepts no responsibility for infection by computer viruses entering the system via an Internet connection and for leaks of hospital, patient and other information.  
Also, do NOT connect the system to a network on another PC that can be connected to the Internet.
- Do NOT apply any shocks to the system components.
- Do NOT place anything which may generate magnetic fields near the system components.
- Do NOT alter the system settings. Do NOT install any software to the system other than that provided by Shimadzu for this system.  
Otherwise, the system may fail to start up.

## Measurement Accuracy



Prohibitions

**Do NOT attempt to use the measurement function for purposes other than references for evaluation because precise image measurement is not possible.**

**- English -****Cautions on Data Loss**

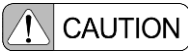

**CAUTION**



**Instructions**

**Either archive (backup) important images or raw data in an external file system such as optical disks, or print it on film.**

If for some reason individual data is lost or corrupted, Shimadzu may adjust the system to prevent a reoccurrence of data loss; however, Shimadzu does not guarantee that the lost data can be restored.

Remember that the data stored on the system disk may be lost or corrupted at any time. Data loss may occur due to a decrease in performance of components (age deterioration) as well as a fault or malfunction of the equipment.

Create a hard copy of the image data on film without delay or save it on external media (CD-R or DVD-R) recommended by Shimadzu for safekeeping the important image data. Note that, however, the data recorded on external media may also be lost, and check the recorded data at regular intervals.

**CD-R/DVD-R**

Use the following CD-R or DVD-R disks recommended by Shimadzu for writing or reading of data. If any other disk is used, proper operation is not guaranteed.

Recommended CD-R disks:  
Disks, CD-R P/N: 562-27681-10 (10 per set)

Recommended DVD-R disks:  
Disks, DVD-R P/N: 562-27680-10 (10 per set)

**Cautions on Network Connections**

This equipment connects to the network for the following purposes.

- Obtains patient information, study information, and previous study images from an external equipment.
- Sends study images, study results information, dose information, and maintenance information of equipment to an external equipment.

Connect with the IPv4 network supporting 1000 Base-T/100 Base-T. Use the UTP LAN cable higher than Enhanced Category 5 (Cat 5e).

**Intended Information Flow**

Destination	Typical information
Imager	Study image data
RIS server	Patient information, Study information, Study results information, Dose information
Storage server	Study image data
Remote maintenance server	Maintenance information of equipment

**Effects of Network Failure**

Destination	Effects of network failure
Imager	Unable to print study images.
RIS server	Unable to obtain patient information and study information. Unable to send study results information and dose information.
Storage server	Unable to send study images.
Remote maintenance server	Unable to send maintenance information of equipment.

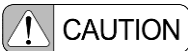

**CAUTION**



**Instructions**

**Shimadzu accepts no responsibility for any of the following items due to infection by malware (i.e. malicious software, including computer viruses and worms, which cause damage to the infected computer):**

- Loss, alteration, and leakage of data, including images, recorded on this equipment
- Accidents due to the malfunction of this equipment
- Infection of other equipment via this equipment and any damages incurred due to the infection
- Other issues including all events caused by malware infection

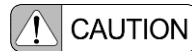

Instructions

**When using the networks described below, the customer must implement security measures to prevent infection by malware (i.e. malicious software, including computer viruses and worms, which causes damage to the infected computer).**

- Networks that lack security management
- Networks that may be subject to malware intrusion
- Networks that are connected to or have the ability to connect to the following devices
  - Devices that lack security management by the customer
  - Devices that can be used by persons unauthorized by the customer
  - Wireless communication devices

Examples of security management are as follows;

- NOT connecting to networks that lack security management
- NOT connecting to the internet
- Checking whether media (external storage media such as FDs, CDs and DVDs) are infected with malware before use.
- Avoiding actions that may result in malware infection
- NOT connecting to the network of another PC connectable to the internet.

Any viral infection or leakage of hospital information or patient information via internet connections is not covered under warranty.



Instructions

**It is strongly recommended that the user identify, analyze, evaluate, and control unacceptable risks resulting from a network connection:**

A connection of the equipment to a network might cause unacceptable risks that were not specified in advance for patients, operators or third parties.

Also, changing the network connection will invite new risks, which will also require additional analysis.

Changing the network connection includes the following:

- Changing the network configuration
- Adding on equipment to the network
- Removing equipment from the network
- Updating equipment connected to the network
- Upgrading equipment connected to the network

## Cautions on Cleaning and Disinfection



Instructions

**Be sure to turn the equipment power OFF before cleaning and disinfecting the equipment.**

Otherwise, a malfunction may occur in the equipment, or the equipment may operate in an unintended way.

Also, thoroughly ventilate the room before turning ON the power after disinfection work is complete.

- English -

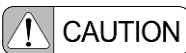

**Be sure to clean and disinfect the equipment periodically.**  
 Cleaning and disinfection is very important to ensure that the equipment can be used hygienically and safely. Strictly follow the methods prescribed.

**Be sure to clean the equipment frequently and after each patient use.**  
 While doing so, do NOT directly apply or spray any disinfectant, cleaner, or water onto the equipment. Wipe down all contact surfaces using a cloth moistened, not soaked, with an appropriate disinfectant or cleaner. Make sure the cloth is NOT too wet. If it is, liquid may enter into system electronics, causing failure or malfunction.

**Use disinfectants at a minimum.**  
 Repeated disinfection over a long time may lead to discoloring and cracking on the equipment surface, and deterioration of rubber and plastic. If any abnormality is found on the equipment after disinfection, stop using the equipment immediately. Contact your Shimadzu service representative for repair.

### Cautions on Emergency Stop

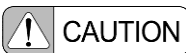

**Press the STOP button or power button to stop the equipment immediately in times of urgency.**  
 Press the STOP button (red button) to stop the X-ray diagnostic table. The STOP button is provided on the front control panel of the X-ray diagnostic table and the console.

Moreover, press the power OFF button  to stop the X-ray generator. The power OFF button is provided on the remote console.

### Cautions Relating to Cellular Telephones







**Do NOT bring any cellular telephones or related devices into the examination room with their power ON.**  
 Such devices can exceed the EMC standard limitations, and under some conditions this can impair the proper functioning of the equipment. In the worst case, this can cause serious injuries or clinical errors.

### Cautions on Electromagnetic Compatibility (EMC)





**This equipment needs special precautions regarding EMC.**  
 Install and use the equipment according to the EMC information provided in this operation manual.

**Make sure that electromagnetic compatibility is obtained.**  
 All peripheral devices must satisfy EMC standards regarding emission of electromagnetic energy and susceptibility to electromagnetic environment.  
 Devices that do not satisfy these standards may disturb the correct functioning of the equipment. In the worst case, this can cause serious injuries or clinical errors.

 <b>WARNING</b>	
	<p><b>Do NOT use this equipment adjacent to, or stacked with, other equipment.</b> If adjacent or stacked use is necessary, check to be sure that this equipment works properly in the environment.</p>
Prohibitions	
	<p><b>Do not use accessories, transducers, or cables other than those specified or supplied by the manufacturer of the equipment.</b> This could cause malfunction due to increased electromagnetic emissions or reduced electromagnetic immunity of the equipment.</p>
Prohibitions	
	<p><b>Do not place a portable RF communications equipment (including peripherals such as antenna cables and external antennas) within 30 cm of any part of the SONIALVISION G4.</b> Doing so may degrade performance of the equipment.</p>
Prohibitions	

### Cautions When Irradiating Consecutive Pulse -shaped X-Ray Fluxes

 <b>WARNING</b>	
	<p><b>Observe the following precautions when irradiating consecutive pulse X-rays:</b></p> <ul style="list-style-type: none"><li>• Conducting studies involving irradiating consecutive pulse X-rays onto the region where an implantable pacemaker or defibrillator is implanted may cause these devices to malfunction.</li><li>• Refer to the "Important General Cautions," "Interactions," or other relevant sections in the accompanying documentation of the implantable pacemaker or defibrillator and take the prescribed measures before irradiating the implanted region of these devices with consecutive pulse X-rays.</li></ul> <p>Fluoroscopy or radiography performed by irradiating consecutive pulse X-rays (such as serial radiography with a few second intervals, pulsed fluoroscopy, digital angiography, DSA, or cineradiography) can adversely affect the CMOS circuit in implantable pacemakers and defibrillators. Such affects may cause oversensing in these devices that can temporarily inhibit pacing pulse output and result in an inappropriate heart rate.</p>
Instructions	

## Digital Angiography System Trinias

### *Precautions in Usage*



**The responsibility for management of use and maintenance of medical equipment lies in a user.**

Use of this device is restricted to use by a diagnostic radiology technician or a person with a certificate indicating equal proficiency.

**Do not remodel the equipment.**

Repair and inspection of the inside of the equipment is dangerous. Make sure to contact our service agency for repair and inspection.

**Perform periodical maintenance.**

Maintenance is required in order to uphold the safety and performance of this equipment. For details on the maintenance inspection to be periodically carried out by the operator, please refer to the description contained in this operation manual.

**Repair and maintenance of equipment can only be performed by engineers to whom Shimadzu assigns.**

Maintenance must be assigned to specially trained experts. Contact the Shimadzu Service Representative for repair and maintenance.

**Do not connect the equipment other than the designed equipment to the system.**

**Considerations against exposure to X-rays**

Improper use of the X-ray equipment might cause the operator or patient to be accidentally exposed to X-ray radiation. During X-ray radiation, any person other than the subject patient should not stay in the irradiation room. If circumstances compel any non-subject person to stay in the room, enough protection should be provided for that person.

**Considerations for mechanical safety**

The operator should be very careful when moving the catheterization table and the C-arm support so that his (or her) or the patient's hand, limb, etc. does not get caught between the table and the C-arm support.

Never splash water to the equipment because you could get an electric shock. When cleaning the equipment, use cloth moistened with an antiseptic solution (Medical Alcohol) to wipe its surface.

**Emergency procedures**

To stop the equipment in an emergency, press the stop switch. This will turn off the power supply.

There is a stop switch (round red switch) which is located on the control console.

The operator should set the focal spot to skin distance as large as practicable to ensure the absorbed dose to the patient is as low as possible.

While performing rotational radiographing, C-arm rotates at high speed around the patient. Should C-arm collide with the patient or the tabletop, the patient may be injured or the equipment may be damaged.

Prior to radiographing, safety check must be performed. While performing rotational radiographing, always keep watching the patient and be ready to press stop switch .

Pay rigid attention so that any object is not placed upon the foot switch or the foot switch is not pressed by mistake. Otherwise, the X-ray may be generated or the table may be moved unexpectedly.

When operating the C-arm, confirm the safety in the operating range of the C-arm. Otherwise, the operator's foot may be caught between C-arm and the floor, or C-arm may collide with other equipment or the patient. It may cause a serious personnel injury.

**Accuracy of displayed values is not guaranteed.**

Displayed values measured by the measurement functions of this equipment are not absolute values but relative values based on the capability of the instruments used.

Measuring a vessel diameter from angiography causes several errors. Therefore, do not diagnose or treat based solely upon this analysis result.

Use the analysis result as a reference value.

Do not use the Injector which is not conformed to the standard of IEC60601-1.

Do not open the covers. This can result in electric shocks.



Do not use in a location where flammable or explosive gases may be generated. The equipment does not have a flameproof construction. Do not use the equipment in a location where flammable or explosive gases may be generated.

Do not use in a location where metal fragments may enter the equipment. This can result in electric shocks.

During X-ray irradiation, ensure that the X-rays irradiate the necessary region only. To avoid X-ray irradiation, narrow down the collimator and take protection measures, such as following items.

- Lower body protector for tabletop rail
- Lead acrylic protective shield
- Protective apron
- Protective glasses
- Protective gloves

**Turn off the power before starting work.**

Always turn off the equipment power before starting cleaning or disinfecting work. Failure to turn off the power can result in electric shock injuries or current leakage.

**Do not directly pour or spray disinfectant onto the equipment. Take due care when using a disinfectant spray.**

Disinfectant entering the equipment can result in electric shock injuries or short circuits. To disinfect the equipment, wipe the surface with a cloth dampened with disinfectant. Do not use disinfectant sprays that may be flammable or explosive. Vapor from these sprays may result in fire or breakdown.

**Thoroughly ventilate the room before turning on the power after disinfection work is complete.**

Flammable gases accumulated in the room may ignite, smoke, explode or cause electric shocks when the power is turned on.

**Do not bring cellular telephones or related devices into the examination room**

Do not bring mobile devices that emit electromagnetic waves (e.g. cellular telephones) into the examination room. Such devices can exceed the EMC electromagnetic wave standards, and under some conditions this can impair the proper functioning of the system. In the worst case, this can cause serious injuries or clinical errors.

**Check that the electromagnetic fields are compatible.**

All peripheral devices must satisfy the EMC standards regarding emission of electromagnetic waves and sensitivity to emitted electromagnetic waves. Devices that do not satisfy these standards may disturb the correct functioning of the system. In the worst case, this can cause serious injuries or clinical errors.

Prepare alternative system with fluoroscopy function, in case any trouble happens and fluoroscopy/radiography cannot be operated normally.

To prevent from generating the unintended X-ray, move the C-arm to the park position and push the X-ray off button of System Display except operating the equipment.

Do not allow operation of this apparatus by any person other than qualified personnel (physicians, radiotherapy engineers and clinical X-ray engineers) or under observation by them.

Do not place unnecessary objects in the area of X-ray exposure. Doing so might subject the patient to unnecessary exposure.

Pay attention to the risk of local skin dose levels that cause tissue reactions under the intended use in the case of repetitive or prolonged exposure.

**Do NOT perform any maintenance work on any part of the equipment during clinical use.**

It may cause injury to patient.



This system operates in the same frequency band as premises radio stations for identifying mobile devices in factory production lines (license required) and specified low-power radio stations (license not required) in addition to industrial devices (ex. microwave ovens), scientific instruments, and medical devices. Other equipment may interfere with the system even if such equipment complies with CISPR EMISSION requirements.

The use of this system may result in RF interference with the above mentioned equipment and radio stations. Make sure you understand and heed the following cautions when operating the system.

- Before using this system, make sure that no RFID premises radio stations and specified low-power radio stations or similar equipment are used in the immediate area.
- If this system causes damaging RF interference to affect an RFID premises radio station, stop using the system immediately and contact your Shimadzu service representative.
- If this system causes damaging RF interference to affect an RFID specified low-power radio station or amateur radio station, contact your Shimadzu service representative.
- This system may suffer interference from other equipment that emits radio waves (such as microwave ovens, Bluetooth devices, and digital cordless telephones). Use the system after moving such devices as far away as possible to prevent interference.

**When using the networks described below, the customer must implement security measures to prevent infection by malware**

**(i.e. malicious software, including computer viruses and worms, which causes damage to the infected computer).**

- Networks that lack security management
- Networks that may be subject to malware intrusion
- Networks that are connected to or have the ability to connect to the following devices
  - Devices that lack security management by the customer
  - Devices that can be used by persons unauthorized by the customer
  - Wireless communication devices

Examples of security management are as follows:

- NOT connecting to networks that lack security management
- NOT connecting to the internet
- Checking whether media (external storage media such as FDs, CDs and DVDs) are infected with malware before use.
- Avoiding actions that may result in malware infection
- NOT connecting to the network of another PC connectable to the internet.

Any viral infection or leakage of hospital information or patient information via internet connections is not covered under warranty.

**It is strongly recommended that the user identify, analyze, evaluate, and control unacceptable risks resulting from a network connection.**

**A connection of the equipment to a network might cause unacceptable risks that were not specified in advance for patients, operators or third parties.**

Also, changing the network connection will invite new risks, which will also require additional analysis.

Changing the network connection includes the following:

- Changing the network configuration
- Adding on equipment to the network
- Removing equipment from the network
- Updating equipment connected to the network
- Upgrading equipment connected to the network

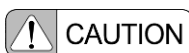

**Be sure to age the X-ray tube!**

It is important to run-in (age) the X-ray tube before commencing actual X-ray irradiation. Follow the aging procedure described in the section X-ray Tube Aging.

Suddenly reverting to the nominal maximum tube voltage range (above 100 kV) after using the X-ray equipment at a relatively low tube voltage (80 kV max.) for a prolonged period may result in arc. This arc occurs due to loss of the high-tube-voltage aging effect if the X-ray equipment is used at a relatively low tube voltage. Follow the X-ray Tube Aging procedure described in the operation manual before using the X-ray equipment at a high tube voltage after a prolonged period of use at a relatively low voltage.

Avoid unnecessary Ready-up. Failure to conduct radiographic operation in the Ready-up status (  lit) may result in a discontinuity or defective withstand voltage due to filament evaporation.

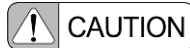

For operating in the control room, provide means for audio and visual communication between the operator and the patient.

**If the operator has no experience in operating the equipment, be sure that he or she receives instruction on how to operate it from our engineers or someone who has enough experience to use the equipment.**

In order to operate the equipment safely, an explanation of the operation needs to be lectured. When installing the equipment, our engineers explain the operating procedure. Follow their directions and operate the equipment correctly.

Consider the following cautions when using a network/data coupling.

- Connection to a network/data coupling that includes other equipment may result in previously unidentified risks to patients, operator or third parties. The administrator of this equipment should identify, analyze, evaluate and control these risks.
- Subsequent changes to the network/data coupling may introduce new risks and require additional analysis. Changes to the network/data coupling include the followings.
  - Changes in network/data coupling configuration
  - Connection of additional items to the network/data coupling
  - Disconnecting items from the network/data coupling
  - Update of equipment connected to the network/data coupling
  - Upgrade of equipment connected to the network/data coupling

Check regularly the available storage capacity on image processing equipment. Be sure to secure and archive important records.

Do not confuse the fluoroscopy and radiography. If the radiography mode is misused on purpose by the operator for real-time imaging, the image display delay may be longer than in the fluoroscopy.

**Do NOT directly apply or spray subbing alcohol or water onto the equipment.**

Wipe the surface of the equipment with a cloth moistened with rubbing alcohol.(intermediate level disinfectant) If rubbing alcohol gets inside the equipment, it can cause failure or accidents.

**Do NOT use the selected frequency channel (2.4 GHz band) for other wireless devices.**

Mutual interference between the system and other devices may result in decreased image data transfer speeds.

**Do NOT cover the wireless receiver of the Wireless Foot Switch with your hands.**

Covering the antenna may hinder the wireless communication properties (throughput and range) of the system.

If wireless foot switch cannot be used due to run out of battery, or does not work stably due to radio wave interference and so on, immediately stop using the wireless foot switch and use the wired foot switch.

In case that two foot-switch units are linked to one output unit, put both foot switch units in the examination room and turn on both during operation even if one of them is not used. If one foot-switch unit is turned off while the other is in use, the active foot switch may not work stably depending on the wireless communication conditions.

For California, USA Only

This product contains a battery that contains perchlorate material.

Perchlorate Material-special handling may apply.

See [www.dtsc.ca.gov/hazardouswaste/perchlorate](http://www.dtsc.ca.gov/hazardouswaste/perchlorate)

- English -

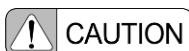

1. This equipment is connected to the network in order to achieve the following purpose.
  - Acquire patient information, study information and past study image from the external equipment.
  - Send study image, study record, dose information and system maintenance information to the external equipment.
2. Connect to the IPv4 network that supports 1000 Base-T/100 Base-T.
3. Use UTP cable with enhanced category 5 (Cat 5e) or higher for LAN cable.
4. Intended information flow

Destination	Typical Information
DICOM Printer	Study image data
MWM server PPS manager	Patient information, Study information Study record, Dose information
DICOM image server	Study image data
Remote maintenance server	System maintenance information

5. Hazardous conditions in case of network failure

Destination	Hazardous Situation
DICOM Printer	Cannot print study image.
MWM server PPS manager	Cannot acquire patient information and study information. Cannot send study record and dose information.
DICOM image server	Cannot send study image. Cannot acquire past study image.
Remote maintenance server	Cannot send system maintenance information.

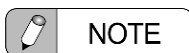

When any serious incident occurred in relation to the system, report that to your Shimadzu service representative and to the competent authority of the Member State in you are established.

“Serious incident” means any incident that directly or indirectly led, might have led or might lead to any of the following:

- (a) the death of a patient, user or other person,
- (b) the temporary or permanent serious deterioration of a patient's, user's or other person's state of health,
- (c) a serious public health threat.

## RADspeed Pro

### Precautions in Usage

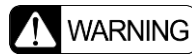

**The responsibility for management of use and maintenance of medical equipment lies with the user.**

This equipment is restricted to use by, or under supervision of, a diagnostic radiology technician or a person with a certificate indicating equal proficiency. Repair and inspection of the inside of the equipment is dangerous. Be sure to contact your Shimadzu service representative for repair and inspection.

**Never modify the equipment.**

In general, modifications are strictly prohibited by the Regulatory requirements of the law of the country where the device is installed. Please contact your Shimadzu service representative if it is necessary to modify the equipment.

**Perform periodic inspection.**

Preventive maintenance is required to maintain long-term safety and performance of the equipment.

The "7 Inspection and Maintenance" chapter in this manual gives detailed descriptions of daily and periodic maintenance and inspection that a user should perform.

As for the maintenance and inspection that only specially trained experts can perform, utilize the maintenance agreement program offered by your Shimadzu service representative.

**Repair and maintenance of the inside of the equipment can only be performed by your Shimadzu service representative.**

Maintenance must be assigned to specially trained experts. Contact your Shimadzu service representative for repair and maintenance.

**Connect this equipment only to Shimadzu certificated devices or devices that are proven to be safe and show no performance degradation in any combination including connecting system.**

**In order to ensure safety when using the system, read the operation manual provided with each system component for details on usage and relevant precautions.**

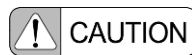

**If the operator has no experience in operating the equipment, be sure that he or she receives instruction on how to operate it from your Shimadzu service representative or someone who has adequate experience in using the equipment.**

In order to operate the equipment safely, an explanation of the operation needs to be given. When installing the equipment, your Shimadzu service representative explains the operating procedure using this operation manual.

Follow their directions and operate the equipment correctly.

**Secure the means for the operator and the patient to communicate with each other.**

If equipment usage is deemed to put the patient at risk due to his or her condition, refrain from conducting the study or treatment.

**Always identify the patient based on the patient information displayed by the equipment before performing exposure.**

(This applies to cases where the system is upgraded to a digital radiography system.)

### Be Sure to Read the Following to Prevent Explosion, Electric Shock, or Injury



**Do NOT use any potentially flammable or explosive gas, such as disinfectant sprays, near the equipment.**

Use of such gas may cause an explosion.



**Check the condition of the patient before conducting a study.**

If equipment usage is deemed to put the patient at risk due to the his or her condition, refrain from conducting the study or treatment.

**Do NOT use the equipment in places where liquid may enter.**

The equipment is not designed to be waterproof. Invasion of any liquid should cause electric shock, system failure or malfunction.

**Do NOT spill any liquid, such as contrast medium, saline, or disinfectant, onto the equipment.**

Should such liquid drip on equipment surfaces, wipe it off immediately. Any such liquid entering into system electronics may cause failure or malfunction.

Should liquid drip on the equipment or enter the covers, immediately turn off the power and contact your Shimadzu service representative.

**When there is any abnormality in operation, or unusual smell or smoke emission during operation, stop operation immediately and contact your Shimadzu service representative.**

Continued use may damage the equipment and cause injury.

**Do NOT open the covers of the equipment.**

Otherwise, electric shock may result. When opening the covers for maintenance, contact your Shimadzu service representative.

**Always be very careful when moving the equipment to avoid contact with the patient or operator and to ensure that the patient or operator does not become caught between the equipment and any neighboring devices.**

Otherwise, it may cause injury.

**Do NOT use in a location where metal fragments may enter the equipment.**

This can result in electric shocks.

**Do NOT perform any maintenance work of the equipment during study.**

The patient may be injured.

**(When combined with CH-200)**

**If the message "Alert: Wire. Stop unit and call service representative" is displayed on the operation touch panel, stop using the equipment and contact your Shimadzu service representative.**

- The equipment is suspended by two wire ropes. If either of these ropes break, radiography is disabled.
- A buzzer sounds continuously when the warning message is displayed on the operation touch panel. Any continued use of the equipment while this message is displayed may result in serious injury to the patient or operator.

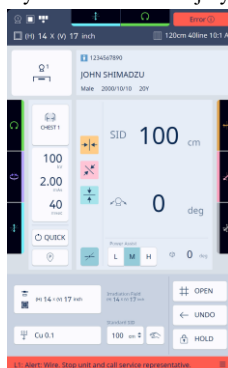

- When combined with the X-ray high-voltage generator D150B-40/V-40/L-40, press the hand switch to display the warning message on the touch panel of the X-ray high-voltage generator D150B-40/V-40/L-40.



(When combined with CH-200M)

**If a warning display and error code [E02] are displayed on the operation panel, stop using the device and immediately contact your Shimadzu service representative.**

- The equipment is suspended by two wire ropes. If either of these ropes break, radiography is disabled.
- A buzzer sounds continuously when the warning message is displayed as an error code on the operation panel. Any continued use of the equipment in this state may result in serious injury to the patient or operator.

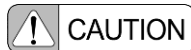
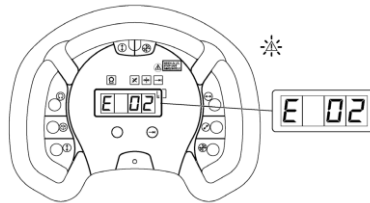

**Wait at least 10 seconds before turning the power on again after shutting it off.**

If you do not, devices may not function correctly.

**When using the system for long periods, take breaks of 10 to 15 minutes every hour to rest your eyes and hands for the sake of your health.**

**Always use the monitor that is a component of the system to read images.**

Other monitors may not be suited to X-ray image diagnosis.

**Perform equipment calibration by appropriately setting the exposure field, grid configuration, and the position of the equipment according to the directions described in the Operation Guide and DR-ID 900 Operation Manual.**

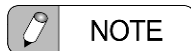

The values displayed by this equipment contain the prescribed margin of error appropriate for the relevant standard.

## Cautions on Environmental Conditions



**Check the condition of the patient before conducting a study.**

If equipment usage is deemed to put the patient at risk due to the his or her condition, refrain from conducting the study or treatment.

**Do NOT use the equipment in places where liquid may enter.**

The equipment is not designed to be waterproof. Invasion of any liquid should cause electric shock, system failure or malfunction.

**Do NOT spill any liquid, such as contrast medium, saline, or disinfectant, onto the equipment.**

Should such liquid drip on equipment surfaces, wipe it off immediately. Any such liquid entering into system electronics may cause failure or malfunction.

Should liquid drip on the equipment or enter the covers, immediately turn off the power and contact your Shimadzu service representative.

**When there is any abnormality in operation, or unusual smell or smoke emission during operation, stop operation immediately and contact your Shimadzu service representative.**

Continued use may damage the equipment and cause injury.

**Do NOT use the equipment in an oxygen-rich environment.**

The use in an oxygen-rich environment may cause fatal or serious injuries or damage to the equipment due to easy ignition.

- English -

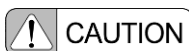

**Abide by the conditions for correct usage.**

Install a dedicated air conditioner to the examination room and run the air conditioner 24 hours to satisfy the specified environmental conditions.

Note also that there must be no sudden changes in temperature or humidity. This causes condensation, which can lead to trouble.

The calorific power of the power supply is not significant enough to affect the use environment of the equipment.

**The power box uses an AC power outlet that accepts three pin plugs for grounding purposes. Do NOT connect the power box to power strips, extension cords, or overloaded electrical circuits.**

**Please confirm input power specifications prescribed for each system configuration.**

This equipment is different in input power rating from X-ray high voltage generators.

**Do NOT let rubber or vinyl contacted with LCD monitor.**

It may cause the deterioration or the paint may come off.

## Cautions on Radiography



**Restrict all persons other than the patient from accessing the equipment in accordance with local regulations.**

To avoid unnecessary exposure, acceptable distances (maximum access values) to the equipment by any person other than the patient are defined for each region.

**The equipment can be operated only by qualified personnel, such as radiology technicians or those with equivalent qualifications.**

**No person but the patient is allowed to stay in the examination room during X-ray irradiation.**

If the equipment is not used correctly, the operator, the patient, and other persons may receive a greater dose of radiation than necessary. If for some reason another person has to be in the examination room, that person must take adequate measures to protect themselves against radiation (protective apron, screen, etc.).

\* During radiography, the radiography indicator illuminates and the buzzer sounds an audible warning.

**Perform X-ray irradiation carefully and according to the doctor's directions when using the equipment with expectant mothers, women who suspect they are pregnant, lactating women, or children.**

Particular ways of using the equipment may increase the scatter dose absorbed into the patient, which may cause a radiation hazard.

**Always check the X-ray exposure region using the collimator lamp.**

Irradiating a patient with X-rays outside the required region risks exposure of the patient to unnecessary radiation.

**During X-ray irradiation, ensure that the X-rays irradiate the necessary region only.**

To avoid unnecessary exposure, narrow down the collimator and take protection measures, such as wearing a protective apron.

**Before starting radiography, confirm the following points:**

- The appropriate radiography protocol has been selected. If you select a wrong radiography protocol for the region of interest or radiography method, the X-ray parameters will not be automatically selected correctly. Apart from that, images will not be processed properly which will prevent the system to deliver its intended performance.
- The appropriate technique, irradiation field and positioning direction have been selected or set.
- The appropriate X-ray parameters have been set. Do NOT expose X-rays if you cannot confirm the X-ray parameters on the operation panel. There is a danger that the patient will be exposed to a greater X-ray dosage than necessary. Apart from that, suitable images will not be obtained.

**Do NOT place any unnecessary object in the location within the X-ray exposure region.**

Doing so may result in unnecessary radiation exposure to the patient.

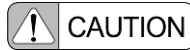

**Be sure to carry out a warm-up (running-in operation of the X-ray tube unit) before taking an X-ray radiograph.**

Follow the warm-up procedure described in the X-ray high voltage generator operation manual.

**Perform the warm-up if an arc occurs.**

Suddenly using the X-ray tube unit near the nominal X-ray tube voltage (above 100 kV) after using the unit at a relatively low tube voltage (80 kV max.) for a prolonged period may result in arc. This arc occurs due to loss of the warm-up effect at high tube voltage after the X-ray tube unit is used at a relatively low tube voltage for a prolonged period.

In this case, warm-up the X-ray tube unit by referring to the procedure described in the X-ray high voltage generator operation manual.

**Do NOT perform unnecessary standby operations.**

If standby status continues after the radiography preparation button is pressed, wire disconnection or withstand voltage failure may result owing to the evaporation of the X-ray tube filament.

**In order to minimize the radiation dose on the patient, make the distance between the focus and the patient's body surface as long as possible (Minimum 45 cm).**

The shorter the distance becomes, the greater the amount of scatter dose absorbed into the patient, which may cause a radiation hazard.

**Pay extra attention when irradiating X-rays for a long time or repeatedly.**

It may cause a radiation hazard.

**In exposure, press and hold down the "READY" switch and "X-RAY" switch until the set exposure time has elapsed.**

Releasing these switches during exposure will prematurely end X-ray irradiation. This may result in failure to acquire a satisfactory exposure image and risks exposing the patient to unnecessary radiation.

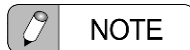

(When combined with DR-ID 900)

If the Virtual Grid software (option) is incorporated, observe the following precautions when performing radiography with Virtual Grid enabled.

- Set appropriate radiography conditions instead of using the AEC function. Use of the AEC function may result in insufficient exposures.
- Image contrast may become high if the additional filter is used. Refer to the DR-ID 900 operation manual and adjust the grid ratio of the Virtual Grid software.
- Image contrast may become high if an FPD is set in the tray of the X-ray radiography stand or the X-ray radiography table. Refer to the DR-ID 900 operation manual and adjust the grid ratio of the Virtual Grid software.

(When combined with digital radiography system)

AEC function should be OFF with grid-less acquisition that be intended to scatter correction\* .

Use of the AEC function may result in insufficient exposures.

\* Scatter correction: This function improves contrast decreased by scattered radiation.

## Cautions on Long View Radiography



**Always set the collimator to "Auto".**

When the collimator is set to "Manual", the equipment is unable to narrow down the exposure field to the region determined from the results of calculation. This risks exposing the patient to unnecessary radiation.

When using the RC-300, switch the manual operation key on the CH-200 LCD screen to the OFF state and set the collimator to automatic operation.

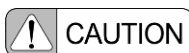
**- English -****Observe the following precautions when using the X-ray radiography stand.**

Failure to do so may result in injury.

- Do NOT allow the patient to become caught between the X-ray radiography stand and the floor when lowering the stand.
- Do NOT allow fingers to become caught in the gap between the Bucky and the X-ray radiography stand for long view radiography.

**Observe the following precautions when using the patient stand for long view radiography.**

Failure to do so may result in damage or accidents.

- Only use the patient stand for long view radiography. Do NOT use the patient stand in other types of radiography.
- Do NOT move the patient stand from the examination room.
- Do NOT push or tilt the patient stand on the floor.
- Do NOT use the patient stand on the floor having an inclination of more than 5°.
- Be sure to keep the patient stand on a flat floor. When keeping it in storage, lock the stoppers at the wheels.
- When moving the patient stand, be careful not to get your foot or an object caught between the floor and the patient stand.
- Do NOT move the patient stand while a patient is resting on it.
- Check that the wheel stoppers on the patient stand are locked.
- Before placing a patient, lock the patient stand to the X-ray radiography stand with the pin and lock its wheels. Do NOT allow the patient to get on while the patient stand is not locked.
- Do NOT allow the patient to come into contact with the backplate when the patient is positioned on the stand.
- Do NOT allow the patient to lean on the stand.
- The patient or operator must exercise caution when moving around the stand to avoid tripping over the setting base.
- Pull the step out completely when using it.
- Before moving the patient stand, push the step inward and keep it completely retracted in position.
- Do NOT hang on the hand grip for patient stand or apply a force greater than 30 kgf.
- Tighten the fastening screw at the hand grip for patient stand firmly.

**Cautions on the FPD****Do NOT touch plugs or connectors with wet hands.**

You could be seriously injured or killed by an electric shock.

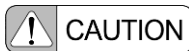

**When using the portable FPD, read the operation manual provided with digital radiography system for details on relevant precautions.**

**Disinfect the applied parts on the surface of the FPD, which the patient comes into contact with, with alcohol every time the patient changes.**

Using the FPD without disinfection could spread infectious diseases.

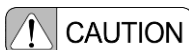
**Cautions on the Cabinet****Do NOT place anything on the control cabinet.**

The internal devices may be damaged if anything falls into the control cabinet ventilation openings.

## Cautions on the Monitor

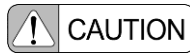

**Do NOT irradiate X-ray when DR-ID 900 monitor shows nothing.**

There is a danger that the patient will be exposed to a greater X-ray dosage than necessary.

**Do NOT touch or swallow the liquid crystal that may leak from the damaged panel.**

It could cause skin irritation. If it gets into the eye, flush the eye with water and call your doctor. If it adheres to skin or clothes, wash it off immediately with water. It contains a stimulating substance.

**Observe the following cautions when using the monitor.**

Failure to observe these cautions can result in fire, electric shock, equipment failure, and shortening of equipment life.

- Do NOT place any object on the monitor or its cables, or cover the monitor or cables with anything.
- Do NOT handle the monitor with wet hands.
- If smoke is emerging or there is a strange smell or noise, turn off the monitor's power switch immediately and pull the power plug out of the outlet.
- If the monitor is dropped or subjected to a strong impact, switch off the monitor's power switch immediately and pull the power plug out of the outlet.
- If any liquid or foreign matter gets inside the monitor, turn off the monitor's power switch immediately and pull the power plug out of the outlet.
- To prevent accidents due to lightning strikes, do NOT touch the power plug or cable after hearing thunder nearby.
- Do NOT use the monitor while it has dew condensation on it.
- Do NOT use the monitor while it is facing upward, or use it built into a site that cannot be ventilated, since this will adversely affect the cabinet and parts.
- Do NOT press against or catch anything against the LCD panel, or rub anything hard against it, such as a ballpoint pen.

**Make sure to use the supplied power cable.**

The use of a cable other than supplied could cause the display to fail.

**The display must be grounded.**

Failure to do so could cause electric shock.

When using a 2P plug, ground the display before plugging into a wall outlet. To remove the grounding cable, unplug the display first.

**Follow the instructions below in handling the power plug.**

It could cause fire or electric shock.

- Hold the plug when unplugging.
- Do NOT plug/unplug with wet hands.
- Do NOT overload wall outlets.
- Dust the plug periodically and keep it dust-free to avoid fire or electric shock.
- Keep the area around the power plug clear so that the plug can be pulled out immediately in an emergency.

**Before moving, fitting or removing the monitor, turn off the power to the devices connected to the monitor and to the monitor itself, and take the power plug out of the power outlet. Handle the monitor by gripping it firmly with both hands.**

**Do NOT install the monitor at locations subject to the following conditions.**

Failure to observe these cautions can result in fire, electric shock, equipment failure, heat generation, ignition or injuries.

- Poor ventilation, dust, high humidity, exposure to oil smoke or steam
- Instability
- Exposure to direct sunlight, proximity to heat-generating equipment
- Outdoors, in a ship, in a vehicle, etc.
- Strong magnetic fields, or vibration
- Exposure to corrosive gases
- Static electricity

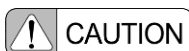
**- English -****Do NOT display a static image for too long.**

It could cause "ghosting," a phenomenon where the previous image displayed on the screen is seen for moments after the image has changed.

**Turn on a screensaver or enable the standby mode to avoid "burning in," the burning of an image onto the LCD panel after hours of the same image being displayed.****Do NOT set maximum luminance or closer to it when using the display in a dim room below 100 lx.**

It could cause eyestrain. We recommend the factory default. Setting it too low could make it hard to see the image.

**Do NOT leave rubber or vinyl products in contact with the LCD monitor for long periods.**

This could cause decomposition, or peeling of the coating.

**When cleaning the monitor, do NOT use solvents such as thinners, benzene, wax, alcohol or abrasive cleaners.**

Never use them on the surface of the LCD panel since they will damage it.

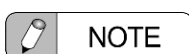

- Even when the monitor is handled correctly, it may be affected by the reception of radio and television signals depending on the prevailing radio wave conditions.

If this happens, observe the following points.

- Use the monitor at a sufficient distance from radios and televisions.
- Connect the monitor at a different power outlet than radios and televisions.

- With LCD panels, observe the following points.

When the panel is used in cold locations the images may leave a trail or may appear dark, but this is not a fault. When the temperature rises it will return to normal. Also, depending on the display conditions, tiny blotches or irregularities may become apparent, but this is not a fault either.

LCD panels utilize extremely high-definition technology and are manufactured with an effective pixel ratio of 99.999466 % or higher, but pixels that display incorrectly (missing, permanently on, etc.) can occur.

- If you plan to leave the unit unused for an extended period, disconnect the power cord from the wall socket after turning off the power switch for the safety and the power conservation.

**Cautions on Cleaning and Disinfection****Be sure to turn the equipment power OFF before cleaning and disinfecting the equipment.**

Otherwise, a malfunction may occur in the equipment, or the equipment may operate in an unintended way.

Also, thoroughly ventilate the room before turning ON the power after disinfection work is complete.

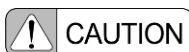
**Be sure to clean and disinfect the equipment periodically.**

Cleaning and disinfection is very important to ensure that the equipment can be used hygienically and safely. Strictly follow the methods prescribed.

**Be sure to clean the equipment frequently and after each patient use.**

While doing so, do NOT directly apply or spray any disinfectant, cleaner, or water onto the equipment. Wipe down all contact surfaces using a cloth moistened, not soaked, with an appropriate disinfectant or cleaner. Make sure the cloth is NOT too wet. If it is, liquid may enter into system electronics, causing failure or malfunction.

**Observe the following precautions when cleaning and disinfecting the touch panel:**

- Do NOT rub or hit the panel surface because it tends to scar easily.
- Wipe gently with moistened, not soaked, soft cloth to remove the dust from the panel surface.

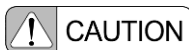

**Wipe the surface of the equipment with a cloth moistened with rubbing alcohol. (intermediate level disinfectant) If rubbing alcohol gets inside the equipment, it can cause failure or accidents. with the following disinfectants or cleaner.**

- Chlorine disinfectants
  - Sodium dichloroisocyanurate solution (1 % maximum)
  - Sodium hypochlorite solution (1 % maximum)
- Alcohol disinfectants
  - Commercially available isopropyl alcohol solution (Up to 99 wt% can be used)
- Rubbing alcohol
  - (76.9 - 81.4 vol% Ethanol, Isopropyl alcohol as an additive)
- Glass cleaner (Only onto the touch panel)

**Do NOT use the following disinfectants:**

If any of the following disinfectants are applied, the equipment performance and safety cannot be guaranteed.

- Disinfectants that corrode metals, plastics, rubber, or paint
- Disinfectants unsuitable for metals, plastics, rubber, or paint
- Spray-gas type disinfectants
- Volatile disinfectants
- Disinfectants that may enter the equipment

**Use disinfectants at a minimum.**

Repeated disinfection over a long time may lead to discoloring and cracking on the equipment surface, and deterioration of rubber and plastic. If any abnormality is found on the equipment after disinfection, stop using the equipment immediately. Contact your Shimadzu service representative for repair.

**Do NOT use an organic solvent.**

Organic solvents may change the surface color. If an organic solvent adheres to the surface, wipe it out immediately.

**When disinfecting unpainted metals, do NOT use chlorine-based disinfectants.**

Chlorine-based disinfectants may corrode the surface of the equipment. If chlorine-based disinfectants adhere to the surface, wipe them off immediately.

**When disinfecting resin parts such as acrylic tabletop and reticule of the collimator, do NOT use rubbing alcohol.**

Rubbing alcohol may lead to deformation or crack of resin parts such as acrylic tabletop and reticule of the collimator. Wipe it off immediately if it adheres to the resin parts.

**When cleaning resin parts such as acrylic tabletop and reticule of the collimator, use cloth lightly moistened, not soaked, with cold or warm water mixed with neutral detergent that does not include organic solvent.**

Rubbing alcohol, organic solvents or non-neutral detergents may lead to deformation or crack of resin parts such as acrylic tabletop and reticule of the collimator. Wipe them off immediately if they adhere to the resin parts.

On completing the work, check the following points before switching the power ON again.

- There must be no water or disinfectant adhering to the equipment.
- The tools used in cleaning and disinfecting work must be tidied away.



**When turning the power ON after cleaning, make sure the examination room is properly ventilated.**

Turning the power ON while any flammable gas remains in the examination room could lead to fire, smoke, explosion or electrocution.

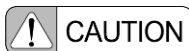
**- English -****Cautions on the System and Software****Observe the following precautions about the system software.**

- Do NOT attempt to alter any system software.  
Doing so could disrupt the functioning of the system and result in loss of images.
- Do NOT attempt to alter any system hardware components.  
Doing so could disrupt the functioning of the system and result in loss of images. Use of any hardware components not provided by Shimadzu is strictly prohibited. This includes peripherals (mouse, keyboard, monitor, etc.).
- Pay careful attention to other high frequency-generating equipment in the room.  
The DR-ID 900 console PC cabinet should be as far as possible from any such device to prevent noise from affecting the image video signal.
- Do NOT disconnect the cables connected to this system.  
Otherwise the image may not be displayed, the data may be damaged and the system may not be started up.
- Do NOT move any system component.  
If necessary, move it carefully to avoid damaging.
- Do NOT apply any shocks to the system components.
- Do NOT place anything which may generate magnetic fields near the system components.
- Do NOT alter the system setting.  
Do NOT install any software to the system other than that provided by Shimadzu for this system.  
Otherwise, the system may not be started up.

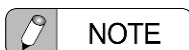

- Before performing an examination, check that the patient information - the patient name and patient ID that are displayed by the system – are correct.
- When a correct definite diagnosis is required, make the diagnosis based not on the images output from this system alone but on the results of multiple examinations.

Open Source Software Used in This Product This product uses software whose copyright is owned and distributed by a third party. These software are provided "AS IS" and without warranty of any kind, including warranties of merchantability or fitness for a particular purpose. Refer to the following URL for licenses of the open source software used in this product.

(Please do not inquire about the contents of the software source code.)

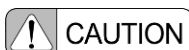
**Cautions on Data Loss****The important image data or original data should be archived (backup) in an external file system such as an optical magnet disc or printed on film.**

Trouble with, or misoperation of, the system hardware, or unexpected accidents, may cause loss of or damage to the image data or the original data stored on the equipment's magnetic disc.

- Shimadzu accepts no responsibility for loss or damaged image data or original data.
- Shimadzu accepts no responsibility whatsoever for incidental, consequential, or indirect damages (destruction to property, loss of opportunities, tangible and intangible damages such as lost profits, etc.) resulting from or arising out of using, not using, or inability to use the equipment.
- External file systems, such as media, could also be damaged. Create multiple backups to avoid data loss.

**Cautions on Network Connections**

1. This system is connected to a network in order to acquire information (specifically, patient information and information related to examinations) from external devices, and to provide data (specifically, examination images and other data) to external devices.
2. Connect the system to a 1000 Base-T, 100 Base-T, or 10 Base-T network compliant with the IEEE standards.
3. Use a UTP type LAN cable compliant with category 5 (CAT 5e) or higher.
4. If any of the following networks are used, the customer is responsible for implementing security measures in order to prevent malware infection (computer viruses, worms, or other malicious software that damages infected computers).
  - (1) Networks without security controls

- (2) Networks accessible to malware
- (3) Networks to which the following devices are or could be connected
  - (i) Devices for which security is not controlled by the customer
  - (ii) Devices that can be used by persons not authorized by the customer
  - (iii) Devices capable of wireless communication
5. The following are examples of security measures.
  - (1) Do NOT connect to networks without security controls.
  - (2) Do NOT connect to the Internet.
  - (3) Confirm that external storage media (such as CD and DVD media) is not infected with malware before using any media.
  - (4) Do NOT perform any actions that could infect equipment with malware.
  - (5) Do NOT connect to networks that include a separate computer that is able to connect to the Internet.

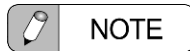

Shimadzu in no way warrants against malware infections or leakage of hospital or patient information due to an Internet connection.

6. Flow of Intended Information
  - (1) RIS server
    - (i) Flow of patient information and information related to examinations
  - (2) Storage server
    - (i) Flow of examination images and other data
  - (3) Print server
    - (i) Flow of examination images and other data, and information for printing
7. Risks When the IT Network Is Down
  - (1) RIS server
    - (i) Examinations cannot be performed.
    - (ii) Examinations cannot be completed.
  - (2) Storage server
    - (i) Examinations (interpretation of images) cannot be performed.
  - (3) Print server
    - (i) Hardcopies of examination images cannot be created.
8. Be aware of the following points when connecting to a network.
  - (1) The network connection for the system may cause unacceptable, unanticipated risks to patients, operators, or third parties.
  - (2) The system administrator must specify, analyse, and evaluate these risks, and specify countermeasures for these risks.
9. If the network connection is changed, new risks may be incurred and additional analysis will also be required. The following matters are included in changes to the network connection.
  - (1) Changes to the network structure
  - (2) Addition of equipment to the network
  - (3) Removal of equipment from the network
  - (4) Updates to equipment connected to the network
  - (5) Upgrades to equipment connected to the network

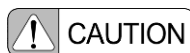

**Shimadzu accepts no responsibility for any of the following items due to infection by malware (i.e. malicious software, including computer viruses and worms, which cause damage to the infected computer):**

- Loss, alteration, and leakage of data, including images, recorded on this equipment
- Accidents due to the malfunction of this equipment
- Infection of other equipment via this equipment and any damages incurred due to the infection
- Other issues including all events caused by malware infection

- English -

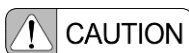

**When using the networks described below, the customer must implement security measures to prevent infection by malware (i.e. malicious software, including computer viruses and worms, which causes damage to the infected computer).**

- Networks that lack security management
- Networks that may be subject to malware intrusion
- Networks that are connected to or have the ability to connect to the following devices
  - Devices that lack security management by the customer
  - Devices that can be used by persons unauthorized by the customer
  - Wireless communication devices
- Examples of security management are as follows ;
- NOT connecting to networks that lack security management
- NOT connecting to the internet
- Checking whether media (such as CDs, DVDs, and external storage devices) are infected with malware before use.
- Avoiding actions that may result in malware infection
- NOT connecting to the network of another PC connectable to the internet.

Any viral infection or leakage of hospital information or patient information via internet connections is not covered under warranty.

It is strongly recommended that the user identify, analyze, evaluate, and control unacceptable risks resulting from a network connection.

A connection of the equipment to a network might cause unacceptable risks that were not specified in advance for patients, operators or third parties.

Also, changing the network connection will invite new risks, which will also require additional analysis.

Changing the network connection includes the following:

- Changing the network configuration
- Adding on equipment to the network
- Removing equipment from the network
- Updating equipment connected to the network
- Upgrading equipment connected to the network

### Cautions Relating to Cellular Telephones



**Do NOT bring any cellular telephones or related devices into the examination room with their power ON.**

Such devices can exceed the EMC standard limitations, and under some conditions this can impair the proper functioning of the equipment. In the worst case, this can cause serious injuries or clinical errors.

### Cautions on Electromagnetic Compatibility (EMC)



**This equipment needs special precautions regarding EMC.**

Install and use the equipment according to the EMC information provided in this operation manual.

**Make sure that electromagnetic compatibility is obtained.**

All peripheral devices must satisfy EMC standards regarding emission of electromagnetic energy and susceptibility to electromagnetic environment.

Devices that do not satisfy these standards may disturb the correct functioning of the equipment. In the worst case, this can cause serious injuries or clinical errors.

**Do NOT use this equipment adjacent to, or stacked with, other equipment.**

If adjacent or stacked use is necessary, check to be sure that this equipment works properly in the environment.



**Do not use accessories, transducers and cables other than those specified or provided by Shimadzu.**

The use of accessories, transducers and cables other than those specified or provided by Shimadzu could result in increased electromagnetic emissions or decreased electromagnetic immunity of this equipment and result in improper operation.

**Portable RF communications equipment (including peripherals such as antenna cables and external antennas) should be used no closer than 30 cm (12 inches) to any part of the RADspeed Pro, including cables specified by the manufacturer.**

Otherwise, degradation of the performance of this equipment could result.

**Portable RF communications equipment (including peripherals such as antenna cables and external antennas) using TETRA (TErrestrial Trunked RADIO) should not be used no closer than 50 cm to any part of the RADspeed Pro, including cables specified by the manufacturer.**

Otherwise, degradation of the performance of this equipment could result.

**Portable RF communications equipment (including peripherals such as antenna cables and external antennas) using Bluetooth, Wireless LAN (2.4 GHz), RFID, LTE (Band7) should not be used no closer than 45 cm to any part of the RADspeed Pro, including cables specified by the manufacturer.**

Otherwise, degradation of the performance of this equipment could result.

**Portable RF communications equipment (including peripherals such as antenna cables and external antennas) using GSM 180, CDMA 1900, GSM 1900, DECT, LTE Band 1,3,4,25, UMTS should not be used no closer than 45 cm to any part of the RADspeed Pro, including cables specified by the manufacturer.**

Otherwise, degradation of the performance of this equipment could result.

### Cautions on Wireless Communication



**This system operates in the same frequency band as premises radio stations for identifying mobile devices in factory production lines (license required) and specified low-power radio stations (license not required) in addition to industrial devices (ex. microwave ovens), scientific instruments, and medical devices. Other equipment may interfere with the system even if such equipment complies with CISPR EMISSION requirements.**

The use of this system may result in RF interference with the above mentioned equipment and radio stations. Make sure you understand and heed the following cautions when operating the system.

- Before using this system, make sure that no RFID premises radio stations and specified low-power radio stations or similar equipment are used in the immediate area.
- If this system causes damaging RF interference to affect an RFID premises radio station, stop using the system immediately and contact your Shimadzu service representative.
- If this system causes damaging RF interference to affect an RFID specified lowpower radio station or amateur radio station, contact your Shimadzu service representative.
- This system may suffer interference from other equipment that emits radio waves (such as microwave ovens, Bluetooth devices, and digital cordless telephones). Use the system after moving such devices as far away as possible to prevent interference.

### Cautions When Irradiating Consecutive Pulse X-Rays



**Observe the following precautions when irradiating consecutive pulse X-rays:**

- Conducting studies involving irradiating consecutive pulse X-rays onto the region where an implantable pacemaker or defibrillator is implanted may cause these devices to malfunction.
- Refer to the "Important General Cautions," "Interactions," or other relevant sections in the accompanying documentation of the implantable pacemaker or defibrillator and take the prescribed measures before irradiating the implanted region of these devices with consecutive pulse X-rays.

Fluoroscopy or radiography performed by irradiating consecutive pulse X-rays (such as serial radiography with a few second intervals, pulsed fluoroscopy, digital angiography, DSA, or cineradiography) can adversely affect the CMOS circuit in implantable pacemakers and defibrillators. Such affects may cause oversensing in these devices that can temporarily inhibit pacing pulse output and result in an inappropriate heart rate.

- English -

## Mobile X-ray System Mobirex i9

### Precautions for Use



**The responsibility for management of use and maintenance of medical equipment lies with the user.**

This system is restricted to use by, or under supervision of, a diagnostic radiology technician or a person with a certificate indicating equal proficiency.

Repair and inspection of the inside of the system is dangerous. Be sure to contact your service representative for repair and inspection.

**Never modify the equipment.**

In general, modifications are strictly prohibited by the Regulatory requirements of the law of the country where the device is installed. Please contact your service representative if it is necessary to modify the system.

**Perform periodic inspection.**

Preventive maintenance is required to maintain long-term safety and performance of the system.

The "5 Maintenance and Inspection" chapter in this manual gives detailed descriptions of daily and periodic maintenance and inspection that a user should perform.

As for the maintenance and inspection that only specially trained experts can perform, utilize the maintenance agreement program offered by Canon.

**Repair and maintenance of the inside of the system can only be performed by engineers assigned by Canon.**

Maintenance must be assigned to specially trained experts. Contact your service representative for repair and maintenance.

**Connect the system only to Canon certificated devices or devices that are proven to be safe and show no performance degradation in any combination including connecting system.**

**In order to ensure safety when using the system, read the operation manual provided with each system component for details on usage and relevant precautions.**

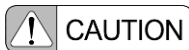

**If the operator has no experience in operating the system, be sure that he or she receives instruction on how to operate it from service personnel or someone who has adequate experience in using the system.**

In order to operate the system safely, an explanation of the operation needs to be given. When installing the system, service personnel explain the operating procedure using this operation manual. Follow their directions and operate the system correctly.

**Secure the means for the operator and the patient to communicate with each other.**

If system usage is deemed to put the patient at risk due to his or her condition, refrain from conducting the study or treatment.

### Be Sure to Read the Following to Prevent Explosion, Electric Shock, or Injury



**Do NOT use any potentially flammable or explosive gas, such as disinfectant sprays, near the equipment.**

Use of such gas may cause an explosion.

**When charging the battery, do NOT use any spark producing instrument, such as an electrocautery, near the system.**

Use of such gas may cause an explosion.

**Do NOT perform any maintenance work of the equipment during study.**

The patient may be injured.



**Check the condition of the patient before conducting a study.**

If system usage is deemed to put the patient at risk due to the his or her condition, refrain from conducting the study or treatment.

**Do NOT use the system in places where liquid may enter.**

The system is not designed to be waterproof.

Invasion of any liquid should cause electric shock, system failure or malfunction.

**Do NOT spill any liquid, such as contrast medium, saline, or disinfectant, onto the system.**

Should such liquid drip on the system surface, wipe it off immediately. Any such liquid entering into system electronics may cause failure or malfunction. Should liquid drip on the X-ray control panel or main monitor, or enter the covers, immediately turn off the power, and contact your service representative.

**If an abnormality occurs during operation, or if an unusual odor or smoke is emitted during operation, stop using the system immediately and contact your service representative.**

Continued use may damage the system and cause injury.

**Do NOT open the covers of the system.**

Otherwise, electric shock may result. When opening the covers for maintenance, contact your service representative.

**Do NOT use in a location where metal fragments may enter the system.**

This can result in electric shocks.

**Be alert to prevent collisions and pinching.**

The operator or patient may sustain injuries if their hands or feet get caught between the arm and the system itself. When moving the arm, grip the designated position and carefully move the arm.

**Charge the battery in a well-ventilated room. Do NOT cover the system while charging the battery.**

### Cautions on Environmental Conditions



**Connect the power supply cord plug to a 3-pin grounded socket. Do NOT connect the system to power strips, extension cords, or overloaded electrical circuits.**

**Do NOT use the system in an oxygen-rich environment.**

The use in an oxygen-rich environment may cause fatal or serious injuries or damage to the system due to easy ignition.

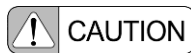

**Be sure to use the system under the specified environmental conditions:**

The installation of a dedicated air-conditioner in the examination room is recommended if the building air-conditioner cannot meet the necessary environmental conditions.

Note also that there must be no sudden change in temperature or humidity. This causes condensation, which can lead to system failure.

### Cautions on Radiography



**Restrict all persons other than the patient from accessing the system in accordance with local regulations.**

To avoid unnecessary exposure, acceptable distances (maximum access values) to the system by any person other than the patient are defined for each region.

**The system can be operated only by qualified personnel, such as radiology technicians or those with equivalent qualifications.**

- English -



**No person but the operator and patient are allowed to stay in the examination room during X-ray irradiation.**

If the system is not used correctly, the operator, the patient, and other persons may receive a greater dose of radiation than necessary.

The operator must control X-ray irradiation from a distance over 2 m from the focal spot and the X-ray beam and also must take adequate measures to protect themselves against radiation (protective apron, screen, etc. are compliant with IEC61331-3).

\*During radiography, the radiography indicator illuminates and the buzzer sounds an audible warning.

**Perform X-ray irradiation carefully and according to the doctor's directions when using the system with expectant mothers, women who suspect they are pregnant, lactating women, or children.**

Particular ways of using the system may increase the scatter dose absorbed into the patient, which may cause a radiation hazard.

**Always check the X-ray exposure region using the collimator lamp.**

Irradiating a patient with X-rays outside the required region risks exposure of the patient to unnecessary radiation.

**During X-ray irradiation, ensure that the X-rays irradiate the necessary region only.**

To avoid unnecessary exposure, narrow down the collimator and take protection measures, such as wearing a protective apron.

**Do NOT place any unnecessary object in the location within the X-ray exposure region.**

Doing so may result in unnecessary radiation exposure to the patient.

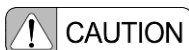

**Be sure to carry out a warm-up (running-in operation of the X-ray tube unit) before taking an X-ray radiograph. Before performing warm-up, be sure to fully close the collimator leaf.**

**If the code [d60] is displayed on the mAs display, stop using the system and immediately contact your service representative.**

**Perform the warm-up if an arc occurs.**

Suddenly using the X-ray tube unit near the nominal X-ray tube voltage (above 100 kV) after using the unit at a relatively low tube voltage (80 kV max.) for a prolonged period may result in arc. This arc occurs due to loss of the warm-up effect at high tube voltage after the X-ray tube unit is used at a relatively low tube voltage for a prolonged period.

**Do NOT perform unnecessary standby operations.**

If standby status continues after the radiography preparation button is pressed, wire disconnection or withstand voltage failure may occur due to the evaporation of the X-ray tube filament.

**In order to minimize the radiation dose on the patient, make the distance between the focus and the patient's body surface as long as possible (Minimum 45 cm).**

The shorter the distance becomes, the greater the amount of scatter dose absorbed into the patient, which may cause a radiation hazard.

**Pay extra attention when irradiating X-rays for a long time or repeatedly.**

It may cause a radiation hazard.

**Avoid prolonged contact with the X-ray tube unit directly after radiography.**

Prolonged contact may cause low temperature burn.

## Cautions Relating to the Laser Beam

The laser beam emitted from the laser marker (option) on the collimator is categorized as a class 1 laser product by the IEC 60825-1:2014, 3rd Edition (effective on 2014-05-15).



### **Never look directly into the laser beam.**

Doing so can cause injuries such as damage to the eyes.

The laser marker (option) can be used only under the supervision of a person with medical knowledge who understands the dangers associated with using a laser beam.

Only switch the laser marker ON when necessary. Avoid unnecessary irradiation.

Do NOT attempt any operation, adjustment or procedure that is not described in this manual. This could result in dangerous laser radiation.

### **Do not let any laser beam enter the patient's eyes.**

Prolonged exposure of the eyes of an anesthetized patient may lead to potentially dangerous exposure if the patient does not close the eyes.

## System Movement Cautions



**When moving the system in areas where there are other people or equipment such as patient rooms and operation rooms, pay attention to the wheels and the base area of the system so as not to bump into infusion stands or run over people's toes or any cables of other equipment.**

Bumping into infusion stands or running over people's toes or any cables of other equipment may cause serious injury.

Note that the obstruction detector cannot detect objects lower than the detector switch or objects that are not heavy enough to activate the detector switch.

**When moving the arm unit or system, the operator must pay close attention to ensure that the limbs of both operator and patient are not caught between the system and any peripheral units.**

Be especially careful when near a wall, changing the direction of the system or moving it backwards.

### **Avoid collisions and overturning.**

Collisions and overturning can not only damage the system, but can also cause serious injury.

Be careful of the following points when moving the system:

- Ensure that there are no obstructions around the system when moving it. When moving the system in the vicinity of people, equipment, or walls, move the system slowly so that it can be stopped at any time while confirming safety in the periphery of the system. Alert people in the periphery so that they do not inadvertently approach the system.
- When on a slope, in an entrance, or encountering obstacles, move the system as slowly as possible. Be especially careful when descending/ascending a steep slope.
- Do NOT move the system on a slope steeper than 7 degrees or over steps higher than 2 cm. When stopping the system, always park the system on a level place, avoiding slopes, since there is a danger of the system rolling down the slope and overturning.
- Moving the system along surfaces that cause strong vibrations, such as roads outdoors, over large steps and down steep slopes is dangerous. Avoid these if possible. Do NOT stop the system on a slope.
- When moving the system, look out for any obstacles in front of it.

**To move the system, firmly grip the grip bar with both hands and then move the system.**

Do NOT operate the grip bar using only one hand, or underhanded. Doing so can result in not only operation errors and system damage, but may also cause serious accidents leading to injury or death.

**Do NOT release the arm lock if the system is on a slope greater than 5 degrees.**

The system may tip over if the arm is rotated, extended/contracted, or moved up or down on a slope greater than 5 degrees.

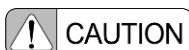

**Do NOT move the system on a wet floor. Otherwise:**

- Liquid may get into the system and cause it to fail.
- The system may slip on the floor and hit an object or person.
- The wheels may deteriorate, making the system unable to move.
- **The obstruction detector cancel function is disabled when the key switch is turned to the OFF  position.**
- **The obstruction detector cancel function is only a temporary measure. If the obstruction detector does not function normally, contact your service representative.**
- **While the obstruction detector cancel function is enabled, the detector will not emit any sound, even if activated. Because there is no auditory warning, be sure to pay careful attention to the area in the periphery of the system while moving.**
- **After moving to a safe location, disable the obstruction detector cancel function.**

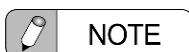

## Battery for Main Unit

To maximize battery life and performance for the main unit, use it in accordance with the following precautions.



### Precautions for Battery Charge

- To maximize battery life and performance, charge the battery after two or more LEDs on the battery indicator go off as far as possible.  
The repetition of charging the battery that has sufficient power remaining may significantly reduce battery life and overall performance.
- If all LEDs on the battery indicator are not illuminated, immediately charge the battery.
- The system starts charging automatically if the power plug remains connected to the outlet and no operation is conducted for a certain period of time.

To start charging immediately, turn the key switch to OFF  and connect the power plug to the outlet. If the key switch is set to ON , the system will not start charging until a certain time elapses.

- Charge the battery under the environmental conditions specified in "1.4 Environmental Conditions". Charging the battery out of the specified environmental conditions may significantly reduce battery life and overall performance.

### Precautions Except for Battery Usage (When DR System is Used)

- Battery consumption progresses if the mobile X-ray system is left for an extended period of time with the DR system running. By performing the setting on the DR system, the DR system can be automatically stopped to reduce battery consumption when a certain period of time elapses with the screensaver displayed.
- The DR system automatically stops when there are no more bars on the battery indicator in order to prevent over-discharge of the battery. However, if the power plug is connected to an outlet, the DR system will not automatically stop because battery consumption is reduced.
- Be sure to connect the power plug to the outlet when using the DR system for a long time.

If the key switch is ON , the DR system will take the power supply from the power plug. The power consumption of the battery can be saved.

### Precautions Except for Battery Usage (When Auto-Power OFF Function is Used)

- If the system is not in use for several days, turn the key switch OFF  regardless of the auto-power-off function being enabled.  
Even if the auto-power-off function shuts the system off, the battery will continue to consume a small amount of power during the shutdown of DR system. Therefore, if the system is left for several days with the autopower-off function enabled, the battery will be discharged completely and it may significantly reduce battery life and overall performance.
- If the DR system is running without connecting the power plug to an outlet, the battery will be completely discharged within a few hours from when the last bar on the battery indicator goes out; this may significantly reduce the battery life and performance.
- The auto-power off function does not turn off the DR system.

By performing the setting on the DR system, the DR system can be automatically stopped to reduce battery consumption when a certain period of time elapses with the screensaver displayed.

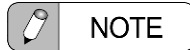

**Precautions for long-term storage**

Never leave the system unused for several months. If the system is not to be used for a long period of time, follow the instructions in "4.5 Storing the System for a Long Period".

**Cautions on Cleaning and Disinfection**



**Be sure to turn the system power OFF before cleaning and disinfecting the system.**

Otherwise, a malfunction may occur in the system, or the system may operate in an unintended way.  
Also, thoroughly ventilate the room before turning ON the power after disinfection work is complete.

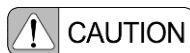

**Be sure to clean and disinfect the system periodically.**

Cleaning and disinfection is very important to ensure that the system can be used hygienically and safely. Strictly follow the methods prescribed.

**Be sure to clean the system frequently and after each patient use.**

While doing so, do NOT directly apply or spray any disinfectant, cleaner, or water onto the system. Wipe down all contact surfaces using a cloth moistened, not soaked, with an appropriate disinfectant or cleaner. Make sure the cloth is NOT too wet. If it is, liquid may enter into system electronics, causing failure or malfunction.

**Before using disinfectant agents, it is necessary to clean the surface of the equipment in advance.**

Please remove the dirt on the surface using a cloth without lint, or a soft toothbrush that does not damage the surface. If dirt is difficult to remove, please dilute dishwasher detergent and soap with lukewarm water, and use them.

Please make sure that the dishwasher detergent and soap used for cleaning is completely wiped off before disinfectant treatment.

**Film-developing or fixing solutions will cause discoloration.**

Wipe off immediately with a cloth.

**Never use paint thinners or other organic solvents.**

Organic solvents may change the surface color. If an organic solvent adheres to the surface, wipe it out immediately.

**Use the following disinfectant:**

- Chlorine disinfectants
  - Sodium dichloroisocyanurate solution (1 % maximum)
  - Sodium hypochlorite solution (1 % maximum)
- Alcohol disinfectants
  - Commercially available isopropyl alcohol solution (Up to 99 wt% can be used)
  - Rubbing alcohol (76.9 - 81.4 vol% Ethanol, Isopropyl alcohol as an additive).

**Do NOT use the following disinfectants:**

If any of the following disinfectants are applied, the system performance and safety cannot be guaranteed.

- Disinfectants that corrode metals, plastics, rubber, or paint
- Disinfectants unsuitable for metals, plastics, rubber, or paint
- Spray-gas type disinfectants
- Volatile disinfectants
- Disinfectants that may enter the system

**Use disinfectants at a minimum.**

Repeated disinfection over a long time may lead to discoloring and cracking on the system surface, and deterioration of rubber and plastic.

If any abnormality is found on the system after disinfection, stop using the system immediately. Contact your service representative for repair.

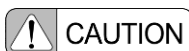
**- English -****When disinfecting unpainted metals, do NOT use chlorine-based disinfectants.**

Chlorine-based disinfectants may corrode the surface of the equipment. If chlorine-based disinfectants adhere to the surface, wipe them off immediately.

**When disinfecting resin parts such as reticule of the collimator and the main monitor, the dose area product meter (option), do NOT use rubbing alcohol.**

Rubbing alcohol may lead to deformation or crack of resin parts such as reticule of the collimator. Wipe it off immediately if it adheres to the resin parts.

**Pay attention to the following points when cleaning or disinfecting the main monitor.**

Do NOT rub or hit the panel surface because it tends to scar easily.

**Pay attention to the following points when cleaning or disinfecting the dose area product meter (option).**

- Make sure no moisture enters the dose area product meter (option) during cleaning.
- After cleaning, dry it thoroughly before use.

On completing the work, check the following points before switching the power ON again.

- There must be no water or disinfectant adhering to the system.
- The tools used in cleaning and disinfecting work must be tidied away.

**When turning the power ON after cleaning, make sure the examination room is properly ventilated.**

Turning the power ON while any flammable gas remains in the examination room could lead to fire, smoke, explosion or electrocution.

**Cautions Relating to Cellular Telephones****Do NOT bring any cellular telephones or related devices into the examination room with their power ON.**

Such devices can exceed the EMC standard limitations, and under some conditions this can impair the proper functioning of the system. In the worst case, this can cause serious injuries or clinical errors.

**Cautions on Electromagnetic Compatibility (EMC)****This system needs special precautions regarding EMC.**

Install and use the system according to the EMC information provided in this operation manual.

**Make sure that electromagnetic compatibility is obtained.**

All peripheral devices must satisfy EMC standards regarding emission of electromagnetic energy and susceptibility to electromagnetic environment.

Devices that do not satisfy these standards may disturb the correct functioning of the system. In the worst case, this can cause serious injuries or clinical errors.

**Do NOT use this system adjacent to, or stacked with, other equipment.**

If adjacent or stacked use is necessary, check to be sure that this system works properly in the environment.

**Portable RF communications equipment (including peripherals such as antenna cables and external antennas) should not be used no closer than 30 cm (12 inches) to any part of the Mobile X-ray System Mobirex i9, including cables specified by the manufacturer.**

Otherwise, degradation of the performance of this equipment could result.



Portable RF communications equipment (including peripherals such as antenna cables and external antennas) using FRS (Family Radio Service) or GMRS (General Mobile Radio Service) should not be used no closer than 3 m (10 feet) to any part of the Mobile X-ray System Mobirex i9, including cables specified by the manufacturer.

Otherwise, degradation of the performance of this equipment could result.

### Cautions on Wireless Communication Using the FPD



This system operates in the same frequency band as premises radio stations for identifying mobile devices in factory production lines (license required) and specified low-power radio stations (license not required) in addition to industrial devices (ex. microwave ovens), scientific instruments, and medical devices. Other equipment may interfere with the system even if such equipment complies with CISPR EMISSION requirements.

The use of this system may result in RF interference with the above mentioned equipment and radio stations. Make sure you understand and heed the following cautions when operating the system.

- Before using this system, make sure that no RFID premises radio stations and specified low-power radio stations or similar equipment are used in the immediate area.
- If this system causes damaging RF interference to affect an RFID premises radio station, stop using the system immediately and contact your service representative.
- If this system causes damaging RF interference to affect an RFID specified low-power radio station or amateur radio station, contact your service representative.
- This system may suffer interference from other equipment that emits radio waves (such as microwave ovens, Bluetooth devices, and digital cordless telephones). Use the system after moving such devices as far away as possible to prevent interference.

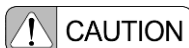

**Do NOT cover the wireless antenna of the FPD with your hands.**

Covering the antenna may hinder the wireless communication properties (throughput and range) of the system.

**Do NOT use the selected frequency channel (2.4 GHz/5 GHz band) for other wireless devices**

Mutual interference between the system and other devices may result in decreased image data transfer speeds.

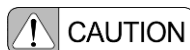
**- English -****Cautions on Built-in AEC Assistance**

The Built-in AEC Assistance (option) of the CXDI-Elite can be used to detect when the FPD pixel value has reached the reference pixel value during radiography. Stopping the X-rays in response to this detection allows for automatic X-ray exposure control.

Use this function while observing the following precautions.

- Even when using the Built-in AEC Assistance, set the appropriate radiography parameters (kV, mAs).  
The Built-in AEC Assistance is a supplementary function.  
If the appropriate radiography parameters are set, the X-rays will be stopped at the set parameters to obtain appropriate images and not result in excessive exposure, even when the timing for the Built-in AEC Assistance stopping the X-rays is delayed.
- Do NOT cover the back of the FPD with any radio wave shielding material.  
It may block the antenna, reducing signal strength, causing a communication delay between the FPD and the access point, and delaying the timing of the Built-in AEC Assistance stopping the X-rays.  
For example, there is a possibility of communication delay between the FPD and the access point if the FPD is stored in a metal tray or placed on the floor for radiography.
- Do NOT cover the access point with any material that shields radio waves.  
It may block the antenna, reducing signal strength, causing a communication delay between the FPD and the access point, and delaying the timing of the Built-in AEC Assistance stopping the X-rays.
- Do NOT use the frequency channel used by the FPD for other wireless devices.  
If there is radio interference from other wireless devices, a communication delay will occur between the FPD and the access point.  
This delays the timing of the Built-in AEC Assistance stopping the X-rays, and under some radiography parameters, the reproducibility may not conform to the IEC60601-2-54.  
When using the Built-in AEC Assistance in locations with radio interference, it is recommended to use a wired connection for radiography.

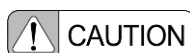
**Cautions Regarding Connection with an External Device**

**When using the system, only the following electrical devices can be connected to the system's LAN connector, USB connector, and DVI (Digital Visual Interface) connector.**

- Medical electrical devices which conform to IEC60601-1
- Non-medical electrical devices which conform to related IEC safety standards
- Non-medical electrical devices which have safety equal to devices which conform to IEC safety standards

**In addition, please note the following:**

1. When connecting medical electrical devices which conform to IEC60601-1  
Connect the system and a connected device with a common protective ground, or connect an additional protective ground of the connected device when that device is in a room not used for treatment and diagnosis (office and storage room, etc.).
2. When connecting other electrical devices
  - (1) Connect an additional protective ground of the connected device, or supply electrical power to the connected device from an isolated power source when the connected device is in the room used for treatment and diagnosis.
  - (2) Connect the system and a connected device with common protective ground, or connect an additional protective ground of the connected device when that device is in a room not used for treatment and diagnosis (office and storage room, etc.).

Table:

Necessary measures when connecting electrical device to this system

Connected Device	Location of Connected Device	
	Diagnosis and Treatment Room	Other
Medical electrical devices which conform to IEC60601-1	—	Common protective ground or additional protective ground or separation device
Other electrical devices	Additional protective ground or power supply from an isolated power source	

**Do NOT allow the connector to be exposed to water or other liquids.**

Exposure to liquid may cause failure or malfunction.

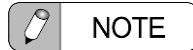

**NOTE**

Do NOT connect external monitors that are not configured for connection.  
Only external monitors that have been configured for connection in advance can be connected to the external monitor interface. Connecting an external monitor that has not been configured for connection will cause both the main unit monitor and external monitor to display incorrectly. If you wish to add a new external monitor, contact your service representative with the connection configuration.

## Cautions on Network Connections

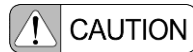

**CAUTION**

**The customer should identify, analyze, evaluate and control RISK by Network.**  
**The customer connection of this machine to a NETWORK that includes other equipment could result in previously unidentified RISKS to PATIENTS, OPERATORS or third parties;**  
**Subsequent changes to the NETWORK could introduce new RISKS and require additional analysis.**  
**Changes to the NETWORK include:**

- Changes in NETWORK/DATA COUPLING configuration
- Connection of additional items to the NETWORK
- Disconnecting items from the NETWORK
- Update of equipment connected to the NETWORK
- Upgrade of equipment connected to the NETWORK

**Shimadzu accepts no responsibility for any of the following items due to infection by malware (i.e. malicious software, including computer viruses and worms, which cause damage to the infected computer):**

- Loss, alteration, and leakage of data, including images, recorded on this system
- Accidents due to the malfunction of this system
- Infection of other equipment via this system and any damages incurred due to the infection
- Other issues including all events caused by malware infection

**When using the networks described below, the customer must implement security measures to prevent infection by malware (i.e. malicious software, including computer viruses and worms, which causes damage to the infected computer).**

- Networks that lack security management
- Networks that may be subject to malware intrusion
- Networks that are connected to or have the ability to connect to the following devices
  - Devices that lack security management by the customer
  - Devices that can be used by persons unauthorized by the customer
- Wireless communication devices
- Examples of security management are as follows ;
- NOT connecting to networks that lack security management
- NOT connecting to the internet
- Avoiding actions that may result in malware infection
- NOT connecting to the network of another PC connectable to the internet.

Any viral infection or leakage of hospital information or patient information via internet connections is not covered under warranty.

## Scope of Software License

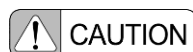

**CAUTION**

**Do NOT change any of the OS settings.**  
The system uses Windows 10 as its operating system (OS).  
If the OS settings are changed, the system operation is not guaranteed.

- English -

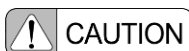

#### **1. Definition of licensed software**

The licensed software ("software") refers to all computer programs used by the system, in addition to all related documentation.

#### **2. Ownership of license**

The software used in this system is copyrighted by Shimadzu Corporation ("Shimadzu"), who possesses all rights, including sublicenses for those rights (for copyrights, etc.) held by third parties.

The system with the installed software is sold on the basis of Shimadzu licensing the software ownership to the customer.

Accordingly, when the customer uses the software, they must observe the items outlined below:

- (1) The customer shall only use the software for use with a single system.
- (2) The intellectual property rights for the software are not transferred to the customer.
- (3) The customer, or any third party, is prohibited from performing any of the following actions:
  - Duplicating the software.
  - Changing the software, in whole or part.
  - Transferring, loaning, or sublicensing the software.
  - Transferring the software outside Japan without the prior permission of the Japanese or U.S. government.

## **Data Security**

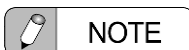

- If individual data stored in the system is either lost or destroyed, Canon may provide system maintenance to prevent future data loss. Canon does not guarantee the retrieval of any lost or damaged data.
- Data stored in the system is always subject to the risk of loss or damage. Loss of or damage to data may result from system failure or malfunction, and may also arise as a result of the deterioration of part performance due to age. To avoid data loss or damage, users are recommended to save all essential data to a hard media, such as film, or store it on an external file system. Data stored on external file systems are also subject to the risk of loss or damage. Regularly check the contents of data stored on external file systems.

## SURGICAL MOBILE C-ARM IMAGING SYSTEM OPESCOPE ACTENO (I.I. Type)

### *Precautions in Usage*

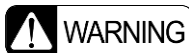

**The responsibility for management of use and maintenance of medical equipment lies with the user.**

This equipment is restricted to use by, or under supervision of, a diagnostic radiology technician or a person with a certificate indicating equal proficiency. Repair and inspection of the inside of the equipment is dangerous. Be sure to contact your Shimadzu service representative for repair and inspection.

**Never modify the equipment.**

In general, modifications are strictly prohibited by the Regulatory requirements of the law of the country where the device is installed. Please contact your Shimadzu service representative if it is necessary to modify the equipment.

**Perform periodic inspection.**

Preventive maintenance is required to maintain long-term safety and performance of the equipment.

The 6 "Maintenance and Inspections" chapter in this manual gives detailed descriptions of daily and periodic maintenance and inspection that a user should perform.

As for the maintenance and inspection that only specially trained experts can perform, utilize the maintenance agreement program offered by Shimadzu.

**Repair and maintenance of the inside of the equipment can only be performed by engineers assigned by Shimadzu.**

Maintenance must be assigned to specially trained experts. Contact your Shimadzu service representative for repair and maintenance.

**Prepare alternative system with fluoroscopy function, in case any trouble happens and fluoroscopy/radiography can not be operated normally.**

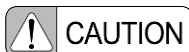

**If the operator has no experience in operating the equipment, be sure that he or she receives instruction on how to operate it from Shimadzu service personnel or someone who has adequate experience in using the equipment.**

In order to operate the equipment safely, an explanation of the operation needs to be given. When installing the equipment, Shimadzu service personnel explain the operating procedure using this instruction manual. Follow their directions and operate the equipment correctly.

### **Be Sure to Read the Following to Prevent Explosion, Electric Shock, or Injury**



**Do NOT use any potentially flammable or explosive gas, such as disinfectant sprays, near the equipment.**

Use of such gas may cause an explosion.



**Check the condition of the patient before conducting a study.**

If equipment usage is deemed to put the patient at risk due to the his or her condition, refrain from conducting the study or treatment.

**Do NOT use the equipment at places where the liquid may enter.**

**Do NOT spill liquids onto the surface or the inside of the equipment.**

Otherwise, electric shock may occur.

In case of liquid spillage to the equipment, immediately turn off the power, and contact your Shimadzu service representative.

- English -

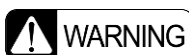

**If an abnormality occurs during operation, or if an unusual odor or smoke is emitted during operation, stop using the equipment immediately and contact your Shimadzu service representative.**

Continued use may damage the equipment and cause injury.

**Do NOT open the covers of the equipment.**

Otherwise, electric shock may result. When opening the covers for maintenance, contact your Shimadzu service representative.

**Always be very careful when moving the equipment to avoid contact with the patient or operator and to ensure that the patient or operator does not become caught between the equipment and any neighboring devices.**

Otherwise, it may cause injury.

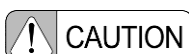

**When moving the C-arm, hold each of the handles to operate it.**

Otherwise, you may trap your fingers, causing injury.

**Do not operate the C-arm with your hand on the knob of the Grid removable kit.**

It is dangerous when the grid may come off unintentionally.

**When opening and closing the monitors, be careful not to trap your fingers.**

Otherwise, it may cause injury.

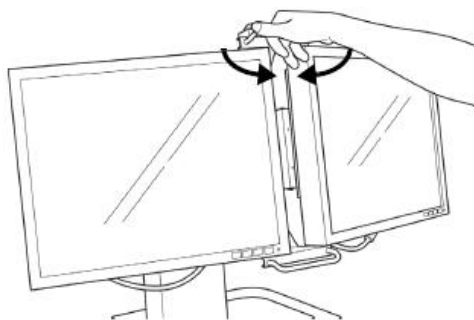

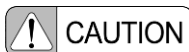

**Do NOT place peripheral devices or any other object within the range of motion of the equipment.**

If you place peripheral devices such as monitors within the range indicated below, the equipment could strike or contact them.

(Units: mm)

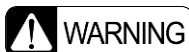
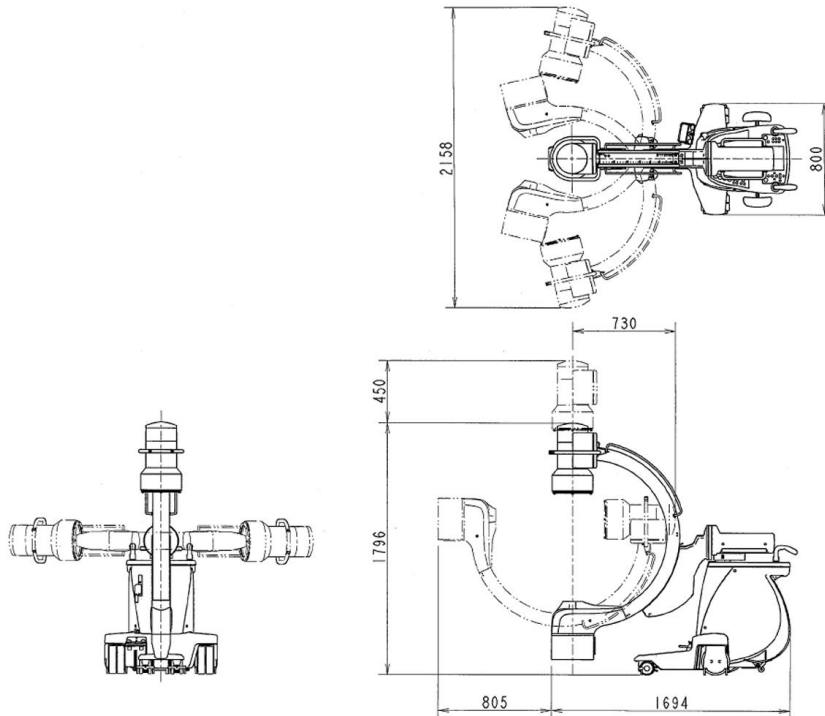

**Do Not perform any maintenance work for the equipment while conducting a study.**

Doing so may cause injury to the patient.

### Cautions on Environmental Conditions

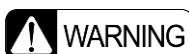

**Use the equipment in an environment that meets the stipulations stated here.**

Use the equipment only in a room or area that conforms to the laws (or regulations with legal force) that govern the electrical safety of this kind of equipment.

**Do NOT use the equipment in an oxygen-rich environment.**

The use in an oxygen-rich environment may cause fatal or serious injuries or damage to the equipment due to easy ignition.

**Be sure to connect the equipment only to a (commercial) power outlet with a ground terminal.**

**Do NOT connect the equipment to power stripes, extension cords, or overloaded electrical circuits.**

Doing so may cause the electric shock.

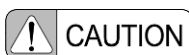

**Be sure to use the equipment under the following environmental conditions:**

The installation of a dedicated air-conditioner in the examination room is recommended if the building air-conditioner cannot meet the necessary environmental conditions.

- Atmosphere: No explosive or corrosive gases
- Ambient temperature: 10 °C to 35 °C
- Relative humidity: 30 % to 80 % (no condensation)
- Atmospheric pressure: 800 hPa to 1060 hPa (800 mbar to 1060 mbar)
- Environment luminosity: 150 lx to 500 lx
- Ambient noise level: Under 70 dB

Note also that there must be no sudden change in temperature or humidity.  
This causes condensation, which can lead to equipment failure.

**Provide the equipment with a suitable ground.**

The equipment needs a ground.  
An unsuitable ground could cause electric shocks.

## Cautions on Radiography



**Restrict all persons other than the patient from accessing the equipment in accordance with local regulations.**

To avoid unnecessary exposure, acceptable distances (maximum access values) to the equipment by any person other than the patient are defined for each region.



**The equipment must only be operated by qualified personnel, such as radiology technicians or those with equivalent qualifications.**

**Perform X-ray irradiation carefully and according to the doctor's directions when using the equipment with expectant mothers, women who suspect they are pregnant, lactating women, or children.**

Particular ways of using the equipment may increase the scatter dose absorbed into the patient, which may cause a radiation hazard.

**During X-ray irradiation, ensure that the X-rays irradiate the necessary region only.**

To avoid unnecessary exposure, narrow down the collimator and take protection measures, such as wearing a protective apron.

**Do NOT place any unnecessary object in the location within the X-ray exposure region.**

Doing so may result in unnecessary radiation exposure to the patient.

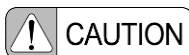

**Be sure to warm-up the equipment (running-in operation of the X-ray tube unit) before fluoroscopy or radiography.**

If the equipment is not used for a prolonged period, perform warm-up (running-in operation of the X-ray tube unit) periodically (approximately once a week).

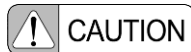

**CAUTION**

**Perform the warm-up if an arc occurs.**

Suddenly using the X-ray tube unit near the nominal X-ray tube voltage (above 100 kV) after using the unit at a relatively low tube voltage (80 kV max.) for a prolonged period may result in arc. This arc occurs due to loss of the warm-up effect at high tube voltage after the X-ray tube unit is used at a relatively low tube voltage for a prolonged period.

In this case, warm-up the X-ray tube unit by referring to the procedure described in the X-ray high voltage generator operation manual.

**Do NOT perform unnecessary standby operations.**

If standby status continues after the radiography preparation switch is pressed, wire disconnection or withstand voltage failure may occur due to the evaporation of the X-ray tube filament.

**In order to minimize the radiation dose on the patient, make the distance between the focus and the patient's body surface as long as possible (Minimum 45 cm).**

The shorter the distance becomes, the greater the amount of scatter dose absorbed into the patient, which may cause a radiation hazard.

**Pay extra attention when irradiating X-rays for a long time or repeatedly.**

It may cause a radiation hazard.

**Do NOT confuse the fluoroscopy and radiography.**

If the radiography mode is misused on purpose by the operator for real-time imaging, the image display delay may be longer than in the fluoroscopy.

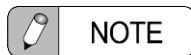

**NOTE**

Objects such as the operating table or surgical instruments in the X-ray exposure area may adversely affect the image quality or dose.

The radiation dose changes when changing tube voltage, dose setting, pulse rate, etc.

## Cautions Relating to the Laser Beam



**WARNING**

**Never look directly into the laser beam.**

Doing so can cause injuries such as damage to the eyes.

The laser pointer (option) can be used only under the supervision of a person with medical knowledge who understands the dangers associated with using a laser beam.

Only switch the laser pointer ON when necessary. Avoid unnecessary irradiation.

Do NOT attempt any operation, adjustment or procedure that is not described in this manual. This could result in dangerous laser radiation.

- Laser pointer (normal type) at monotank side and I.I. side

The laser beam emitted from the laser pointer (option) is categorized as a class 1 laser by the IEC 60825-1:2014, 3<sup>rd</sup> Edition (effective on 2014-05-15).

- Laser pointer (high emission type) at I.I. side

The laser beam emitted from the laser pointer (option) has a wavelength of 515 nm (nanometers) and an output of less than 3 mW and consequently is categorized as a class 3R laser by the IEC 60825-1:2014, 3<sup>rd</sup> Edition (effective on 2014-05-15).



**WARNING**

**Do not let any laser beam enter the patient's eyes.**

Prolonged exposure of the eyes of an anesthetized patient may lead to potentially dangerous exposure if the patient does not close the eyes.

This can lead to risks that exceed the risks associated with the class mentioned above.

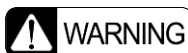
**- English -****Cautions on Moving the Equipment****Take care to avoid impacts and overturning of the equipment.**

The unit alone weighs more than 200 kg.

Impacts and overturning will not only damage the equipment, but could also cause serious injuries.

When moving the equipment, pay attention to the following points.

- When moving the C-arm between rooms, make sure the C-arm is at its home position.
- Check that the cable work has been done correctly.
- When traversing slopes and entrances, and negotiating obstacles, move the equipment as gently as possible. Take particular care on steep slopes.
- Always apply the brake after you stop moving the equipment.
- Do NOT move the equipment over any steps or bumps greater than 2 cm, or Do NOT use the equipment on a floor that is sloped more than 5 degrees.
- Always stop the equipment on a level surface and avoid sloped surfaces. Failure to do so may cause the equipment to roll down the slope or tip over.
- In places where moving the equipment generates strong vibrations, for example outdoor paths, avoid rapid progress, deep steps, and steep slopes. Do NOT stop moving on inclined routes.
- While wheeling the equipment, watch out for obstacles ahead.

**Measurement Accuracy**

**When used in combination with the DR option, values are displayed as "mm" and "deg" when the DR option measurement function is used.**

**Do NOT attempt to use the measurement function for purposes other than references for evaluation because precise image measurement is not possible.**

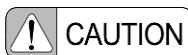
**Cautions on the System and Software****Observe the following precautions:**

- Do NOT attempt to alter any system software.  
Doing so could disrupt the functioning of the system and result in loss of images.
- Do NOT attempt to alter any system hardware components.  
Doing so could disrupt the functioning of the system and result in loss of images. Use of any hardware components not provided by Shimadzu is strictly prohibited. This includes peripherals (mouse, keyboard, monitor, etc.).
- Pay careful attention to other high frequency-generating equipment in the room. The monitor cart should be as far as possible from any such device to prevent noise from affecting the image video signal.
- Do NOT disconnect the cables connected to this system.  
Otherwise the image may not be displayed, the data may be damaged and the system may fail to start up.
- Do NOT move any system component.  
If necessary, move it carefully to avoid damage.
- Do NOT apply any shocks to the system components.
- Do NOT place anything which may generate magnetic fields near the system components.
- Do NOT alter the system setting. Do NOT install any software to the system other than that provided by Shimadzu for this system.  
Otherwise, the system may fail to start up.

 **NOTE**

- Before performing an exposure, always identify the patient based on the patient information displayed on the equipment.
- Do NOT delete the program conditions or move the saved location.  
 The program conditions set on the X-ray high voltage generator are linked with the DR console.  
 If you do delete them, a system malfunction may occur.

### Cautions on Data Loss

 **CAUTION**

**The important image data or original data should be archived (backup) in an external file system such as an optical magnet disc or printed on film.**

A system hardware failure, misoperation, or contingent accidents may cause loss of, or damage to the image data or the original data stored in the magnetic disc of the equipment.

- Shimadzu accepts no responsibility for loss or damaged image data or original data.
- Shimadzu accepts no responsibility whatsoever for incidental, consequential, or indirect damages (destruction to property, loss of opportunities, tangible and intangible damages such as lost profits, etc.) resulting from or arising out of using, not using, or inability to use the equipment.
- External file systems, such as media, could also be damaged.  
 Create multiple backups to avoid data loss.

**Do NOT disconnect the LAN cable when transferring of image data to the DICOM storage server.**

Doing so may cause loss of or damage to the image data or the original data stored on the magnetic disc of the equipment.

### Cautions on Network Connections

The equipment connects to the network to obtain patient information and study information from external devices and to output data such as study images to external devices. The equipment shall be connected to the network supporting 1000 Base-T/100 Base-T/10 Base-T based on the IEEE standard. The LAN cable shall be compatible with UTP that is rated for CAT 5e or higher.

Intended information flow

Connection destination	Typical information
Imager	Study image data
RIS server	Patient information, Study information, Study record information, and Dose information
Storage server	Study image data

 **CAUTION**

**The following hazardous situation may occur in the event of a network outage.**

- Imager: Study images cannot be printed.
- RIS server: Patient information and study information cannot be obtained and study record information and dose information cannot be sent.
- Storage server: Study images cannot be sent, and past study images cannot be obtained.

**Shimadzu accepts no responsibility for any of the following items due to infection by malware (i.e. malicious software, including computer viruses and worms, which cause damage to the infected computer):**

- Loss, alteration, and leakage of data, including images, recorded on this equipment
- Accidents due to the malfunction of this equipment
- Infection of other equipment via this equipment and any damages incurred due to the infection
- Other issues including all events caused by malware infection

- English -

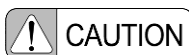

**When using the networks described below, the customer must implement security measures to prevent infection by malware (i.e. malicious software, including computer viruses and worms, which causes damage to the infected computer).**

- Networks that lack security management
- Networks that may be subject to malware intrusion
- Networks that are connected to or have the ability to connect to the following devices
  - (1) Devices that lack security management by the customer
  - (2) Devices that can be used by persons unauthorized by the customer
  - (3) Wireless communication devices

Examples of security management are as follows;

- NOT connecting to networks that lack security management
- NOT connecting to the internet
- Checking whether media (such as CDs, DVDs, and external storage devices) are infected with malware before use.
- Avoiding actions that may result in malware infection
- NOT connecting to the network of another PC connectable to the internet.

Any viral infection or leakage of hospital information or patient information via internet connections is not covered under warranty.

**The customer should identify, analyze, evaluate and control RISK by Network.**

The customer connection of this machine to a NETWORK that includes other equipment could result in previously unidentified RISKS to PATIENTS, OPERATORS or third parties;

Subsequent changes to the NETWORK could introduce new RISKS and require additional analysis.

Changes to the NETWORK include:

- Changes in NETWORK configuration
- Connection of additional items to the NETWORK
- Disconnecting items from the NETWORK
- Update of equipment connected to the NETWORK
- Upgrade of equipment connected to the NETWORK

## Cautions on Cleaning and Disinfection



**Be sure to turn the equipment power OFF before cleaning and disinfecting the equipment.**

Otherwise, a malfunction may occur in the equipment, or the equipment may operate in an unintended way.

Also, thoroughly ventilate the room before turning ON the power after disinfection work is complete.

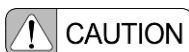

**Be sure to clean and disinfect the equipment.**

Cleaning and disinfection is very important to ensure that the equipment can be used hygienically and safely. Strictly follow the methods prescribed.

**Clean the equipment surface before using disinfectant.**

Clean the surface with a lint-free cloth or a soft toothbrush that does not scratch the surface. If it is difficult to remove dirt, please use dishwashing detergent or soap diluted with lukewarm water. Be sure to wipe off any dishwashing detergent or soap used for cleaning before disinfection.

**Do not spray disinfectant or water directly on the equipment.**

Wipe the surface of the equipment with a cloth soaked with disinfectant. If disinfectant gets inside the equipment, it can cause failure or accidents.

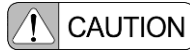

**The following disinfectants (intermediate level disinfectant) are available. However, depending on the object, there are restrictions on the disinfectant that can be used. Please wipe off the disinfectant after disinfection.**

(A) Chlorine disinfectants\*<sup>1</sup>

- Sodium dichloroisocyanurate solution (1% maximum)
- Sodium hypochlorite solution (1% maximum)

(B) Alcohol disinfectants\*<sup>2</sup>

- Commercially available isopropyl alcohol sodium (up to 99 wt% can be used)
- Rubbing alcohol (76.9 - 81.4 vol% Ethanol, isopropyl alcohol as an additive)

\*<sup>1</sup>: Do not use on unpainted metal parts. Using chlorine disinfectant may cause corrosion.

\*<sup>2</sup>: Do not use for plastic parts, especially the following acrylic parts:

Alcohol-based disinfectants may deteriorate.

- (i) Transparent plastic part of laser light transmitting part
- (ii) Touch panel
- (iii) Front plastic part of the X-ray I.I. unit

**Do NOT use the following disinfectants:**

The use of these disinfectants cannot guarantee the performance and safety of the equipment.

- Disinfectants that corrode metals, plastics, rubber, or paint
- Disinfectants unsuitable for metals, plastics, rubber, or paint
- Spray-gas type disinfectants
- Volatile disinfectants
- Disinfectants that may enter the equipment

**Do NOT use an organic solvent.**

Organic solvents may change the surface color. If an organic solvent adheres to the surface, wipe it off immediately.

**Use disinfectants at a minimum.**

Repeated disinfection over a long time may lead to discoloring and cracking on the equipment shape or plastic. For example, rubber and plastic may deteriorate. If any abnormality is found on the equipment after disinfection, stop using the equipment immediately. Contact your Shimadzu service representative for repair.

**Do NOT directly apply or spray disinfectant or water onto the equipment.**

Wipe the surface of the equipment with a cloth soaked with designated disinfectant.

If liquid gets inside the equipment, it can cause failure or accidents.

**Observe the following precautions when cleaning and disinfecting the touch panel:**

- Disconnect the main power cable before cleaning and disinfecting.
- Clean and disinfect the touch panel periodically. The applicable cleaners include, isopropyl alcohol (abrasive free), glass cleaner (non ammonia-based), water solution of neutral detergent.
- Handle the touch panel with care when cleaning and disinfecting. Do NOT rub or hit the panel surface because it tends to scar easily.
- Wipe gently with moistened soft cloth to remove the dust from the panel surface.

**Before a study or operation, remove the dust from the X-ray I.I. unit, C-arm, X-ray tube assembly, and the periphery.**

## Cautions Relating to Cellular Telephones



**Do NOT bring any cellular telephones or related devices into the examination room with their power ON.**

Such devices can exceed the EMC standard limitations, and under some conditions this can impair the proper functioning of the equipment. In the worst case, this can cause serious injuries or clinical errors.

- English -

## Cautions on Electromagnetic Compatibility (EMC)



**This equipment needs special precautions regarding EMC.**

Install and use the equipment according to the EMC information provided in this instruction manual.

**Make sure that electromagnetic compatibility is obtained.**

All peripheral devices must satisfy EMC standards regarding emission of electromagnetic energy and susceptibility to electromagnetic environment.

Devices that do not satisfy these standards may disturb the correct functioning of the equipment. In the worst case, this can cause serious injuries or clinical errors.

**Do NOT use this equipment adjacent to, or stacked with, other equipment.**

If adjacent or stacked use is necessary, check to be sure that this equipment works properly in the environment.

**Portable RF communications equipment (including peripherals such as antenna cables and external antennas) should not be used no closer than 30 cm (12 inches) to any part of the Surgical Mobile C-arm Imaging System OPESCOPE ACTENO, including cables specified by the manufacturer.**

Otherwise, degradation of the performance of this equipment could result.

## Cautions When Irradiating Consecutive Pulse X-rays



**Observe the following precautions when irradiating consecutive pulse X-rays:**

- Conducting studies involving irradiating consecutive pulse X-rays onto the region where an implantable pacemaker or defibrillator is implanted may cause these devices to malfunction.
- Refer to the "Important General Cautions," "Interactions," or other relevant sections in the accompanying documentation of the implantable pacemaker or defibrillator and take the prescribed measures before irradiating the implanted region of these devices with consecutive pulse X-rays.

Fluoroscopy or radiography performed by irradiating consecutive pulse X-rays (such as serial radiography with a few second intervals, pulsed fluoroscopy, digital angiography, DSA, or cineradiography) can adversely affect the CMOS circuit in implantable pacemakers and defibrillators. Such affects may cause oversensing in these devices that can temporarily inhibit pacing pulse output and result in an inappropriate heart rate.

## SURGICAL MOBILE C-ARM IMAGING SYSTEM OPESCOPE ACTENO (FD Type)

### *Precautions for Use*



**The responsibility for management of use and maintenance of medical equipment lies with the user.**

This equipment is restricted to use by, or under supervision of, a diagnostic radiology technician or a person with a certificate indicating equal proficiency. Repair and inspection of the inside of the equipment is dangerous. Be sure to contact your Shimadzu service representative for repair and inspection.

**Never modify the equipment.**

In general, modifications are strictly prohibited by the Regulatory requirements of the law of the country where the device is installed. Please contact your Shimadzu service representative if it is necessary to modify the equipment.

**Perform periodic inspection.**

Preventive maintenance is required to maintain long-term safety and performance of the equipment.

The 6 "Maintenance and Inspections" chapter in this manual gives detailed descriptions of daily and periodic maintenance and inspection that a user should perform.

As for the maintenance and inspection that only specially trained experts can perform, utilize the maintenance agreement program offered by Shimadzu.

**Repair and maintenance of the inside of the equipment can only be performed by engineers assigned by Shimadzu.**

Maintenance must be assigned to specially trained experts. Contact your Shimadzu service representative for repair and maintenance.

**Prepare another OPESCOPE ACTENO or alternative fluoroscopic system with specifications greater than or equal to the OPESCOPE ACTENO, in case any trouble happens and fluoroscopy/radiography cannot be operated normally.**

**Do not use this equipment alone for diagnosis.**

Make a diagnosis based on not only the output image of the equipment but also multiple test results.

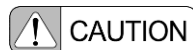

**If the operator has no experience in operating the equipment, be sure that he or she receives instruction on how to operate it from Shimadzu service personnel or someone who has adequate experience in using the equipment.**

given. When installing the equipment, Shimadzu service personnel explain the operating procedure using this instruction manual. Follow their directions and operate the equipment correctly.

### **Be Sure to Read the Following to Prevent Explosion, Electric Shock, or Injury**



**Do NOT use any potentially flammable or explosive gas, such as disinfectant sprays, near the equipment.**

Use of such gas may cause an explosion.



**Check the condition of the patient before conducting a study.**

If equipment usage is deemed to put the patient at risk due to the his or her condition, refrain from conducting the study or treatment.

- English -



**Do NOT use the equipment at places where the liquid may enter.**

**Do NOT spill liquids onto the surface or the inside of the equipment.**

Otherwise, electric shock may occur.

In case of liquid spillage to the equipment, immediately turn off the power, and contact your Shimadzu service representative.

**If an abnormality occurs during operation, or if an unusual odor or smoke is emitted during operation, stop using the equipment immediately and contact your Shimadzu service representative.**

Continued use may damage the equipment and cause injury.

**Do NOT open the covers of the equipment.**

Otherwise, electric shock may result. When opening the covers for maintenance, contact your Shimadzu service representative.

**Always be very careful when moving the equipment to avoid contact with the patient or operator and to ensure that the patient or operator does not become caught between the equipment and any neighboring devices.**

Otherwise, it may cause injury.

**When performing CPR, immediately move this equipment away so it does not obstruct CPR.**

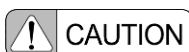

**When moving the C-arm, hold each of the handles to operate it.**

Otherwise, you may trap your fingers, causing injury.

**When opening and closing the monitors, be careful not to trap your fingers.**

Otherwise, it may cause injury.

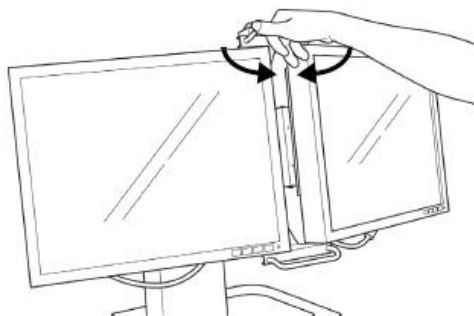

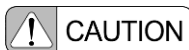

**Do NOT place peripheral devices or any other object within the range of motion of the equipment.**

If you place peripheral devices such as monitors within the range indicated below, the equipment could strike or contact them.

(Units: mm)

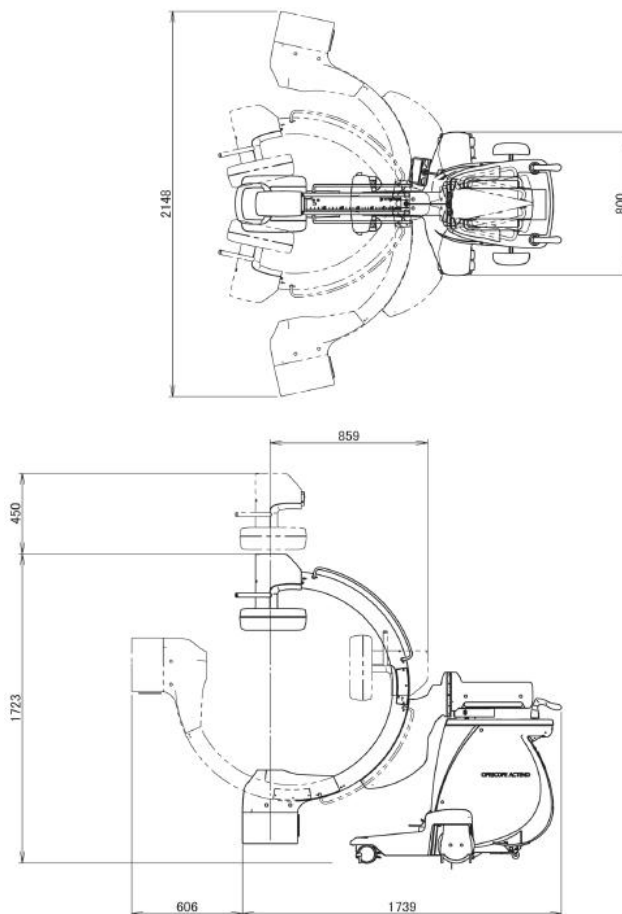

**Do Not perform any maintenance work for the equipment while conducting a study.**

Doing so may cause injury to the patient.

### Cautions on Environmental Conditions



**Use the equipment in an environment that meets the stipulations stated here.**

Use the equipment only in a room or area that conforms to the laws (or regulations with legal force) that govern the electrical safety of this kind of equipment.

**Do NOT use the equipment in an oxygen-rich environment.**

The use in an oxygen-rich environment may cause fatal or serious injuries or damage to the equipment due to easy ignition.

**Be sure to connect the equipment only to a (commercial) power outlet with a ground terminal.**

**Do NOT connect the equipment to power stripes, extension cords, or overloaded electrical circuits.**

Doing so may cause the electric shock.

- English -

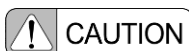

**Be sure to use the equipment under the following environmental conditions:**

The installation of a dedicated air-conditioner in the examination room is recommended if the building air-conditioner cannot meet the necessary environmental conditions.

- Atmosphere: No explosive or corrosive gases
- Ambient temperature: 10 °C to 35 °C
- Relative humidity: 30 % to 80 % (no condensation)
- Atmospheric pressure: 800 hPa to 1060 hPa (800 mbar to 1060 mbar)
- Environment luminosity: 150 lx to 500 lx
- Ambient noise level: Under 70 dB

Note also that there must be no sudden change in temperature or humidity.

This causes condensation, which can lead to equipment failure.

**Provide the equipment with a suitable ground.**

The equipment needs a ground.

An unsuitable ground could cause electric shocks.

## Cautions on Radiography



**Restrict all persons other than the patient from accessing the equipment in accordance with local regulations.**

To avoid unnecessary exposure, acceptable distances (maximum access values) to the equipment by any person other than the patient are defined for each region.



**The equipment must only be operated by qualified personnel, such as radiology technicians or those with equivalent qualifications.**

**Perform X-ray irradiation carefully and according to the doctor's directions when using the equipment with expectant mothers, women who suspect they are pregnant, lactating women, or children.**

Particular ways of using the equipment may increase the scatter dose absorbed into the patient, which may cause a radiation hazard.

**During X-ray irradiation, ensure that the X-rays irradiate the necessary region only.**

To avoid unnecessary exposure, narrow down the collimator and take protection measures, such as wearing a protective apron.

**Do NOT place any unnecessary object in the location within the X-ray exposure region.**

Doing so may result in unnecessary radiation exposure to the patient.

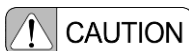

**Be sure to warm-up the equipment (running-in operation of the X-ray tube unit) before fluoroscopy or radiography.**

If the equipment is not used for a prolonged period, perform warm-up (running-in operation of the X-ray tube unit) periodically (approximately once a week).

**Perform the warm-up if an arc occurs.**

Suddenly using the X-ray tube unit near the nominal X-ray tube voltage (above 100 kV) after using the unit at a relatively low tube voltage (80 kV max.) for a prolonged period may result in arc. This arc occurs due to loss of the warm-up effect at high tube voltage after the X-ray tube unit is used at a relatively low tube voltage for a prolonged period.

In this case, warm-up the X-ray tube unit by referring to the procedure described in the X-ray high voltage generator operation manual.

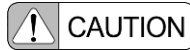

**Do NOT perform unnecessary standby operations.**

If standby status continues after the radiography preparation switch is pressed, wire disconnection or withstand voltage failure may occur due to the evaporation of the X-ray tube filament.

**In order to minimize the radiation dose on the patient, make the distance between the focus and the patient's body surface as long as possible (Minimum 45 cm).**

The shorter the distance becomes, the greater the amount of scatter dose absorbed into the patient, which may cause a radiation hazard.

**Do NOT confuse the fluoroscopy and radiography.**

If the radiography mode is misused on purpose by the operator for real-time imaging, the image display delay may be longer than in the fluoroscopy.

**Pay extra attention when irradiating X-rays for a long time or repeatedly.**

It may cause a radiation hazard.

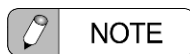

Objects such as the operating table or surgical instruments in the X-ray exposure area may adversely affect the image quality or dose.

The radiation dose changes when changing tube voltage, dose settings, pulse rate, etc.

### Cautions Relating to the Laser Beam

The laser beam emitted from the laser pointer (option) on the X-ray tube assembly and FPD sides is categorized as a class 1 laser by the IEC 60825-1:2014, 3<sup>rd</sup> Edition (effective on 2014-05-15).



**Never look directly into the laser beam.**

Doing so can cause injuries such as damage to the eyes.

The laser pointer (option) can be used only under the supervision of a person with medical knowledge who understands the dangers associated with using a laser beam.

Only switch the laser pointer ON when necessary. Avoid unnecessary irradiation.

Do NOT attempt any operation, adjustment or procedure that is not described in this manual. This could result in dangerous laser radiation.

**Do not let any laser beam enter the patient's eyes.**

Prolonged exposure of the eyes of an anesthetized patient may lead to potentially dangerous exposure if the patient does not close the eyes.

**- English -****Cautions on Moving the Equipment****Take care to avoid impacts and overturning of the equipment.**

The unit alone weighs more than 200 kg.

Impacts and overturning will not only damage the equipment, but could also cause serious injuries.

When moving the equipment, pay attention to the following points.

- When moving the C-arm between rooms, make sure the C-arm is at its home position.
- Check that the cable work has been done correctly.
- When traversing slopes and entrances, and negotiating obstacles, move the equipment as gently as possible. Take particular care on steep slopes.
- Always apply the brake after you stop moving the equipment.
- Do NOT move the equipment over any steps or bumps greater than 2 cm, or Do NOT use the equipment on a floor that is sloped more than 5 degrees.
- Always stop the equipment on a level surface and avoid sloped surfaces. Failure to do so may cause the equipment to roll down the slope or tip over.
- In places where moving the equipment generates strong vibrations, for example outdoor paths, avoid rapid progress, deep steps, and steep slopes. Do NOT stop moving on inclined routes.
- While wheeling the equipment, watch out for obstacles ahead.

**Measurement Accuracy**

Values are displayed as "mm" and "deg" when the DR measurement function is used.

**Do NOT attempt to use the measurement function for purposes other than references for evaluation because precise image measurement is not possible.**

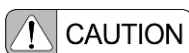
**Cautions on the System and Software****Observe the following precautions:**

- Do NOT attempt to alter any system software.  
Doing so could disrupt the functioning of the system and result in loss of images.
- Do NOT attempt to alter any system hardware components.  
Doing so could disrupt the functioning of the system and result in loss of images. Use of any hardware components not provided by Shimadzu is strictly prohibited. This includes peripherals (mouse, keyboard, monitor, etc.).
- Pay careful attention to other high frequency-generating equipment in the room. The monitor cart should be as far as possible from any such device to prevent noise from affecting the image video signal.
- Do NOT disconnect the cables connected to this system.  
Otherwise the image may not be displayed, the data may be damaged and the system may fail to start up.
- Do NOT move any system component.  
If necessary, move it carefully to avoid damage.
- Do NOT apply any shocks to the system components.
- Do NOT place anything which may generate magnetic fields near the system components.
- Do NOT alter the system setting.  
Do NOT install any software to the system other than that provided by Shimadzu for this system. Otherwise, the system may fail to start up.
- Do NOT allow anyone to touch the equipment except those who have received permission from the equipment manager.  
Personal information is stored in this equipment. Do not let unauthorized persons touch the equipment during use or storage.

 NOTE

- Before performing an exposure, always identify the patient based on the patient information displayed on the equipment.
- Do NOT delete the program conditions or move the saved location.  
 The program conditions set on the X-ray high voltage generator are linked with the DR console.  
 If you do delete them, a system malfunction may occur.

### Cautions on Data Loss

 CAUTION

**The important image data or original data should be archived (backup) in an external file system such as an optical magnet disc.**

A system hardware failure, misoperation, or contingent accidents may cause loss of, or damage to the image data or the original data stored in the magnetic disc of the equipment.

- Shimadzu accepts no responsibility for loss or damaged image data or original data.
- Shimadzu accepts no responsibility whatsoever for incidental, consequential, or indirect damages (destruction to property, loss of opportunities, tangible and intangible damages such as lost profits, etc.) resulting from or arising out of using, not using, or inability to use the equipment.
- External file systems, such as media, could also be damaged.  
 Create multiple backups to avoid data loss.

**Do not disconnect the wired or wireless LAN while the equipment is communicating.**

Data in communication or data in the equipment may be abnormal or damaged.

### Cautions on Network Connections

The equipment connects to the network to obtain patient information and study information from external devices and to output data such as study images to external devices. The equipment shall be connected to the network supporting 1000 Base-T/100 Base-T/10 Base-T based on the IEEE standard. The LAN cable shall be compatible with UTP that is rated for CAT 5e or higher.

You can also use a wireless LAN unit to wirelessly connect the device to the network. When using the wireless LAN unit, keep it away from the channels used by other devices. If the operating frequency overlaps with that of another device, the communication quality may be degraded. Even if the wireless connection is fully connected, communication might fail due to the environmental influence. In this case, try communicating again. If retrying fails, check the network status.

Intended information flow

Connection destination	Typical information
Imager	Study image data
RIS server	Patient information, Study information, Study record information, and Dose information
Storage server	Study image data

 CAUTION

**The wireless LAN unit uses radio waves to exchange information. Failure to implement appropriate security measures may result in the interception of communication data by a malicious third party or unauthorized access.**

When using the wireless LAN unit, it is the customer's responsibility to implement security measures. If you communicate over a network that is not under security control, information leakage might occur due to network eavesdropping or falsification of communication data, or due to source or destination address spoofing. Do not communicate over an unsecured network.

**The following hazardous situation may occur in the event of a network outage.**

- Imager: Study images cannot be printed.
- RIS server: Patient information and study information cannot be obtained and study record information and dose information cannot be sent.
- Storage server: Study images cannot be sent, and past study images cannot be obtained.

- English -

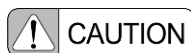

**Shimadzu accepts no responsibility for any of the following items due to infection by malware (i.e. malicious software, including computer viruses and worms, which cause damage to the infected computer):**

- Loss, alteration, and leakage of data, including images, recorded on this equipment
- Accidents due to the malfunction of this equipment
- Infection of other equipment via this equipment and any damages incurred due to the infection
- Other issues including all events caused by malware infection

**When using the networks described below, the customer must implement security measures to prevent infection by malware (i.e. malicious software, including computer viruses and worms, which causes damage to the infected computer).**

- Networks that lack security management
- Networks that may be subject to malware intrusion
- Networks that are connected to or have the ability to connect to the following devices
  - (1) Devices that lack security management by the customer
  - (2) Devices that can be used by persons unauthorized by the customer
  - (3) Wireless communication devices

Examples of security management are as follows;

- NOT connecting to networks that lack security management
- NOT connecting to the internet
- Checking whether media (such as CDs, DVDs, and external storage devices) are infected with malware before use.
- Avoiding actions that may result in malware infection
- NOT connecting to the network of another PC connectable to the internet.

If security measures are not implemented, any virus infection, or leakage or falsification of hospital and patient information is not covered under warranty.

**The customer should identify, analyze, evaluate and control RISK by Network.**

The customer connection of this machine to a NETWORK that includes other equipment could result in previously unidentified RISKS to PATIENTS, OPERATORS or third parties;

Subsequent changes to the NETWORK could introduce new RISKS and require additional analysis.

Changes to the NETWORK include:

- Changes in NETWORK configuration
- Connection of additional items to the NETWORK
- Disconnecting items from the NETWORK
- Update of equipment connected to the NETWORK
- Upgrade of equipment connected to the NETWORK

## Cautions on Cleaning and Disinfection



**Be sure to turn the equipment power OFF before cleaning and disinfecting the equipment.**

Otherwise, a malfunction may occur in the equipment, or the equipment may operate in an unintended way.

Also, thoroughly ventilate the room before turning ON the power after disinfection work is complete. If flammable gases remain in the room and the system is turned on, fire, smoke, explosion or electric shock may occur.

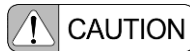

**Be sure to clean and disinfect the equipment.**

Cleaning and disinfection is very important to ensure that the equipment can be used hygienically and safely. Strictly follow the methods prescribed.

**Clean the equipment surface before using disinfectant.**

Clean the surface with a lint-free cloth or a soft toothbrush that does not scratch the surface. If it is difficult to remove dirt, please use dishwashing detergent or soap diluted with lukewarm water. Be sure to wipe off any dishwashing detergent or soap used for cleaning before disinfection.

**Do not spray disinfectant or water directly on the equipment.**

Wipe the surface of the equipment with a cloth soaked with disinfectant. If disinfectant gets inside the equipment, it can cause failure or accidents.

**The following disinfectants (intermediate level disinfectant) are available. However, depending on the object, there are restrictions on the disinfectant that can be used. Please wipe off the disinfectant after disinfection.**

(A) Chlorine disinfectants\*<sup>1</sup>

- Sodium dichloroisocyanurate solution (1% maximum)
- Sodium hypochlorite solution (1% maximum)

(B) Alcohol disinfectants\*<sup>2</sup>

- Commercially available isopropyl alcohol sodium (up to 99 wt% can be used)
- Rubbing alcohol (76.9 - 81.4 vol% Ethanol, isopropyl alcohol as an additive)

\*<sup>1</sup>: Do not use on unpainted metal parts. Using chlorine disinfectant may cause corrosion.

\*<sup>2</sup>: Do not use for plastic parts, especially the following acrylic parts:

Alcohol-based disinfectants may deteriorate.

- (i) Transparent plastic part of laser light transmitting part
- (ii) Touch panel
- (iii) Front plastic part of the X-ray I.I. unit

**Do NOT use the following disinfectants:**

The use of these disinfectants cannot guarantee the performance and safety of the equipment.

- Disinfectants that corrode metals, plastics, rubber, or paint
- Disinfectants unsuitable for metals, plastics, rubber, or paint
- Spray-gas type disinfectants
- Volatile disinfectants
- Disinfectants that may enter the equipment

**Do NOT use an organic solvent.**

Organic solvents may change the surface color. If an organic solvent adheres to the surface, wipe it off immediately.

**Use disinfectants at a minimum.**

Repeated disinfection over a long time may lead to discoloring and cracking on the equipment shape or resin. For example, rubber and plastic may deteriorate. If any abnormality is found on the equipment after disinfection, stop using the equipment immediately. Contact your Shimadzu service representative for repair.

**Observe the following precautions when cleaning and disinfecting the touch panel:**

- Disconnect the main power cable before cleaning and disinfecting.
- Clean and disinfect the touch panel periodically. The applicable cleaners include, isopropyl alcohol (abrasive free), glass cleaner (non ammonia-based), water solution of neutral detergent.
- Handle the touch panel with care when cleaning and disinfecting. Do NOT rub or hit the panel surface because it tends to scar easily.
- Wipe gently with moistened soft cloth to remove the dust from the panel surface.

**Before a study or operation, remove the dust from the X-ray I.I. unit, C-arm, X-ray tube assembly, and the periphery.**

- English -

### Cautions Relating to Cellular Telephones



**Do NOT bring any cellular telephones or related devices into the examination room with their power ON.**

Such devices can exceed the EMC standard limitations, and under some conditions this can impair the proper functioning of the equipment. In the worst case, this can cause serious injuries or clinical errors.

### Cautions on Electromagnetic Compatibility (EMC)



**This equipment needs special precautions regarding EMC.**

Install and use the equipment according to the EMC information provided in this instruction manual.

**Make sure that electromagnetic compatibility is obtained.**

All peripheral devices must satisfy EMC standards regarding emission of electromagnetic energy and susceptibility to electromagnetic environment.

Devices that do not satisfy these standards may disturb the correct functioning of the equipment. In the worst case, this can cause serious injuries or clinical errors.

**Do NOT use this equipment adjacent to, or stacked with, other equipment.**

If adjacent or stacked use is necessary, check to be sure that this equipment works properly in the environment.

**such as antenna cables and external antennas) should not be used no closer than 30 cm (12 inches) to any part of the Surgical Mobile C-arm Imaging System OPESCOPE ACTENO FD type, including cables specified by the manufacturer.**

Otherwise, degradation of the performance of this equipment could result.

### Cautions When Irradiating Consecutive Pulse X-rays



**Observe the following precautions when irradiating consecutive pulse X-rays:**

- Conducting studies involving irradiating consecutive pulse X-rays onto the region where an implantable pacemaker or defibrillator is implanted may cause these devices to malfunction.
- Refer to the "Important General Cautions," "Interactions," or other relevant sections in the digitized accompanying documentation of the implantable pacemaker or defibrillator and take the prescribed measures before irradiating the implanted region of these devices with consecutive pulse X-rays.

Fluoroscopy or radiography performed by irradiating consecutive pulse X-rays (such as serial radiography with a few second intervals, pulsed fluoroscopy, digital angiography, DSA, or cineradiography) can adversely affect the CMOS circuit in implantable pacemakers and defibrillators. Such affects may cause oversensing in these devices that can temporarily inhibit pacing pulse output and result in an inappropriate heart rate.

## X-RAY R/F SYSTEM FLUOROspeed

### Precautions for Use

 **WARNING**

 **The responsibility for management of use and maintenance of medical equipment lies with the user.**  
This equipment is restricted to use by, or under supervision of, a diagnostic radiology technician or a person with a certificate indicating equal proficiency. Repair and inspection of the inside of the equipment is dangerous. Be sure to contact your Shimadzu service representative for repair and inspection.

Instructions

 **Never modify the equipment.**  
requirements of the law of the country where the device is installed. Please contact your Shimadzu service representative if it is necessary to modify the equipment.

Prohibitions

 **Perform periodic inspection.**  
Preventive maintenance is required to maintain long-term safety and performance of the equipment. The "6 Maintenance" chapter in this manual gives detailed descriptions of daily and periodic maintenance and inspection that a user should perform.  
As for the maintenance and inspection that only specially trained experts can perform, utilize the maintenance agreement program offered by Shimadzu.

Instructions

 **Repair and maintenance of the inside of the equipment can only be performed by engineers assigned by Shimadzu.**  
Maintenance must be assigned to specially trained experts. Contact your Shimadzu service representative for repair and maintenance.

Instructions

 **In order to ensure safety when using the system, read the operation manual provided with each system component for details on usage and relevant precautions.**

Instructions

 **CAUTION**

 **If the operator has no experience in operating the equipment, be sure that he or she receives instruction on how to operate it from Shimadzu service personnel or someone who has adequate experience in using the equipment.**  
In order to operate the equipment safely, an explanation of the operation needs to be given. When installing the equipment, Shimadzu service personnel explain the operating procedure using this instruction manual. Follow their directions and operate the equipment correctly.

Instructions

 **Secure the means for the operator and the patient to communicate with each other.**  
If equipment usage is deemed to put the patient at risk due to his or her condition, refrain from conducting the study or treatment.

Instructions









### Be Sure to Read the Following to Prevent Explosion, Electric Shock, or Injury

 **DANGER**

 **Do NOT use any potentially flammable or explosive gas, such as disinfectant sprays, near the equipment.**  
Use of such gas may cause an explosion.

Prohibitions

 **WARNING**

	<p><b>Check the condition of the patient before conducting a study.</b> If equipment usage is deemed to put the patient at risk due to the his or her condition, refrain from conducting the study or treatment.</p>
Instructions	
	<p><b>Do NOT use the equipment in places where liquid may enter.</b> The equipment is not designed to be waterproof. Invasion of any liquid should cause electric shock, system failure or malfunction.</p>
Prohibitions	
	<p><b>Do NOT spill any liquid, such as contrast medium, saline, or disinfectant, onto the equipment.</b> Should such liquid drip on equipment surface, wipe it off immediately. Any such liquid entering into system electronics may cause failure or malfunction. Should liquid drip on the operation panel or enter the covers, immediately turn off the power, and contact your Shimadzu service representative.</p>
Prohibitions	
	<p><b>If an abnormality occurs during operation, or if an unusual odor or smoke is emitted during operation, stop using the equipment immediately and contact your Shimadzu service representative.</b> Continued use may damage the equipment and cause injury.</p>
Instructions	
	<p><b>Do NOT open the covers of the equipment.</b> Otherwise, electric shock may result. When opening the covers for maintenance, contact your Shimadzu service representative.</p>
Prohibitions	
	<p><b>Do NOT use in a location where metal fragments may enter the equipment.</b> This may result in electric shock.</p>
Prohibitions	
	<p><b>Always be very careful when moving the table top to avoid contact with the patient or operator and to ensure that the patient or operator does not become caught between the equipment and any neighboring devices.</b> Otherwise, it may cause injury.</p>
Instructions	
	<p><b>Patients who have difficulty with physical activity must be escorted by a caregiver.</b> When a caregiver assists a patient, the operator must ensure the safety of the caregiver as the patient to operate the equipment.</p>
Instructions	
	<p><b>Do NOT perform any maintenance work on any part of the equipment during clinical use.</b> It may cause injury.</p>
Prohibitions	

 **NOTE**

If the following happens, turn the power off and then restart the equipment.

- The X-ray diagnostic table does not function properly but an error message is not displayed, even after operating the table.
- X-rays are not irradiated but an error message is not displayed, even after performing fluoroscopy or radiography operations.
- The digital radiography unit and touch unit cannot be operated or do not respond even if operated.

The values displayed on this equipment may include a margin of error as stipulated in the applicable standards.

## Cautions on Environmental Conditions

 **WARNING**

 **Do NOT use the equipment in an oxygen-rich environment.**  
Using the equipment in an oxygen-rich environment may cause fire, which may lead to fatal or serious injuries to the patient or damage to the equipment.

Prohibitions

 **Do NOT connect the equipment other than the designated equipment to the system.**

Prohibitions

 **CAUTION**

 **Be sure to use the equipment under the following environmental conditions:**  
The installation of a dedicated air-conditioner is recommended if the building air-conditioner cannot maintain the necessary environmental conditions 24 hours a day.

Instructions

Atmosphere:	No explosive gas, highly concentrated oxygen, nor corrosive gas in the atmosphere
Temperature:	10 to 30 °C
Relative humidity:	20 to 70 % (no condensation)
Atmospheric pressure:	800 to 1060 hPa
Environment luminosity:	150 to 500 lx
Ambient noise level:	70 dB max.

There must be no sudden changes in temperature or humidity. This could cause condensation, which may lead to equipment malfunction.

 **Ground the equipment using ground wires.**  
Be sure to carry out grounding according to the installation manual to reduce the danger of electric shock.

Instructions

 **Before using the equipment, ensure correct operations of switches and meters as well as proper connections of high-voltage cables, cords, and ground wires.**

Instructions

 **Do NOT disconnect cords, cables and other connections, unless it is required.**

Prohibitions







 **Contact your Shimadzu service representative for installation and relocation of the equipment.**

Instructions





- English -

## Cautions on Radiography

 **WARNING**

 Instructions	<p><b>Restrict all persons other than the patient from accessing the equipment in accordance with local regulations.</b></p> <p>To avoid unnecessary exposure, acceptable distances (maximum access values) to the equipment by any person other than the patient are defined for each region.</p>
 Instructions	<p><b>The equipment can be operated only by qualified personnel, such as radiology technicians or those with equivalent qualifications.</b></p>
 Prohibitions	<p><b>No person but the patient is allowed to stay in the examination room during X-ray irradiation.</b></p> <p>If the equipment is not used correctly, the operator, the patient, and other persons may receive a greater dose of radiation than necessary. If for some reason another person has to be in the examination room, that person must take adequate measures to protect themselves against radiation (protective apron, screen, etc.).</p>
 Instructions	<p style="text-align: center;">During X-ray irradiation, the alarm sounds, and  lights up and is displayed on the acquisition monitor.</p> <p><b>Perform X-ray irradiation carefully and according to the doctor's directions when using the equipment with expectant mothers, women who suspect they are pregnant, lactating women, or children.</b></p> <p>Particular ways of using the equipment may increase the scatter dose absorbed into the patient, which may cause a radiation hazard.</p>
 Instructions	<p><b>During X-ray irradiation, ensure that the X-rays irradiate the necessary region only.</b></p> <p>To avoid unnecessary exposure, narrow down the collimator and take protection measures, such as wearing a protective apron.</p>
 Prohibitions	<p><b>Do NOT place unnecessary objects in the area of X-ray exposure.</b></p> <p>Doing so might subject the patient to unnecessary exposure.</p>

 **CAUTION**

 Instructions	<p><b>Be sure to warm-up the equipment (running-in operation of the X-ray tube unit) before taking an X-ray radiograph.</b></p>
 Instructions	<p><b>Perform the warm-up if an arc occurs.</b></p> <p>Suddenly using the X-ray tube unit near the nominal X-ray tube voltage (above 100 kV) after using the unit at a relatively low tube voltage (80 kV max.) for a prolonged period may result in arc. This arc occurs due to loss of the warm-up effect at high tube voltage after the X-ray tube unit is used at a relatively low tube voltage for a prolonged period.</p>
 Prohibitions	<p><b>Do NOT perform unnecessary preparation for radiography.</b></p> <p>If radiography has not been performed for long with  (Ready for radiography) lit on the panel, wire disconnection or withstand voltage failure may occur due to the evaporation of the X-ray tube filament.</p>
 Instructions	<p><b>In order to minimize the radiation dose on the patient, make the distance between the focus and the patient's body surface as long as possible (Minimum 45 cm).</b></p> <p>The shorter the distance becomes, the greater the amount of scatter dose absorbed into the patient, which may cause a radiation hazard.</p>

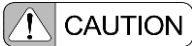

**CAUTION**



**Pay extra attention when irradiating X-rays for a long time or repeatedly.**  
 It may cause a radiation hazard.



**Hold down the exposure start switch or hand switch until the exposure is complete.**  
 If the switch is released partway through, X-ray irradiation is aborted at that point and an appropriate radiograph may not be taken.

Instructions

Instructions

### Cautions Relating to the Laser Beam

The laser beam emitted from the laser pointer (option) on the deck unit of the X-ray diagnostic table is categorized as a class 1 laser by the IEC 60825-1:2014, 3<sup>rd</sup> Edition (effective on 2014-05-15). Class 1 laser products are safe during use, including long-term direct intrabeam viewing.

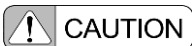

**CAUTION**



**Avoid look directly into the laser beam in low ambient light.**  
 Intrabeam viewing of class 1 laser products which emit visible radiant energy may produce dazzling effects.

Instructions

### System Operation



**WARNING**



**Confirm that there is no apparatus within the operating range when moving the X-ray diagnostic table.**  
 Ensure that no desk, chair, stretcher, foot switch, monitor suspension, etc. is placed within the operating range. The apparatus may be crushed by or collide with the equipment, causing damage.



Instructions



**Ensure that no one is under the X-ray diagnostic table.**  
 The person may become caught under the table and injured.

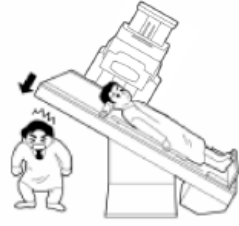

Instructions



**Do NOT put your hand or fingers between the tabletop and the main frame when moving the tabletop.**  
 Otherwise your hand could get caught and injured.

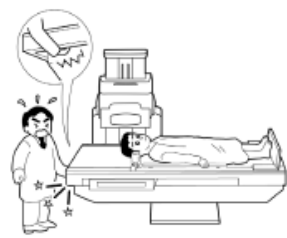



Prohibitions

**⚠ WARNING**

  
Prohibitions

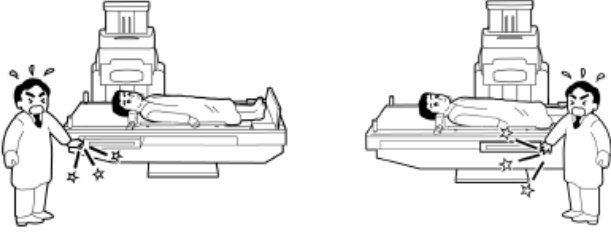
**When operating the tray unit, do NOT place your hand near the tray unit.**  
Otherwise your hand could get caught and injured.



  
Instructions

**Ensure that the patient does not put his or her hand between the tabletop and the imaging unit when moving the imaging unit.**  
Otherwise his or her hand could get caught and injured.



  
Instructions

**Instruct the patient to hold the hand grips when he or she is placed on the tabletop.**  
Instruct the patient to hold the hand grips firmly. Insufficient holding could cause the patient to fall off the tabletop and be injured.

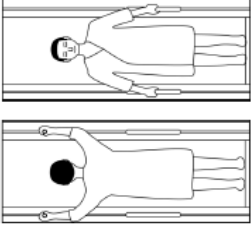

**⚠ CAUTION**

  
Instructions

**Before using the equipment, check the settings on the control device and ensure that the exposure conditions for fluoroscopy or radiography is correctly set.**

  
Prohibitions

**Do NOT place anything on the control cabinet.**  
The internal equipment may be damaged if anything falls into the control cabinet ventilation opening.

  
Prohibitions

**Do NOT allow a stretcher to collide against the front cover of the X-ray diagnostic table.**  
Doing so may damage the front cover.

  
Instructions

**After using the equipment, open the circuit breaker to which the power cord of the high-voltage generator is connected to ensure safety.**

  
Instructions

**It is recommended to keep backup X-ray equipment in case the equipment fails to operate due to a fault.**

## Cautions on the LCD Monitor

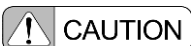
 **CAUTION**

  
Prohibitions

**Do NOT leave rubber or vinyl products in contact with the LCD monitor for long periods.**  
This could cause decomposition, or peeling of the coating.

  
Prohibitions

**Do NOT scratch or hit the LCD monitor surface with a hard material, such as a ballpoint pen.**  
Otherwise, the LCD monitor surface may be damaged.

  
Prohibitions

**Do NOT push hard on the LCD monitor surface.**  
It may cause an uneven image, leading to the monitor's failure.

## Options and Other Parts

 **WARNING**

  

  
Prohibitions

**Do NOT place the foot switch or the foot controller under the X-ray diagnostic table.**  
The operator's foot may get caught under the X-ray diagnostic table and injured.



  
Prohibitions

**Do NOT place anything on the foot switch. Pay extra attention not to step on the foot switch accidentally.**  
Unintended X-rays may be radiated.

  
Prohibitions

**Do NOT place the foot switch in the operating range of the X-ray diagnostic table when it is not used in order to prevent accidental operation.**  
The X-ray diagnostic table may unintentionally move or X-rays may unintentionally be radiated.

  
Prohibitions

**Do NOT place the foot switch or the foot controller in the operating range of the X-ray diagnostic table when it is not used in order to prevent accidental operation.**  
The X-ray diagnostic table may unintentionally move or X-rays may unintentionally be radiated.

 **WARNING**

Instructions

Hold the patient securely so that the patient does not fall from the table. Particularly when tilting the tabletop downward, confirm the patient's safety and operate carefully.



Attach appropriate parts according to the patient's body and body position to hold the patient.

- Foot rest:** Use to keep a patient's foot position when tilting the tabletop.
- Shoulder rests:** Use to prevent a patient from slipping down to the head side when tilting the tabletop downward.
- Hand grips:** Use to hold and change the patient's position when the tabletop is moving laterally or tilted.

After attaching parts, push and pull them in all directions to ensure that they are secured to the equipment firmly to hold the patient's load. Otherwise the patient may fall off and be injured when tilting the tabletop or changing body position.

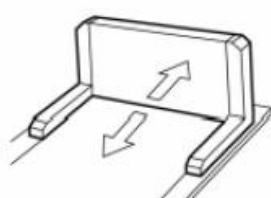

Attaching the foot rest



Attaching a shoulder rest

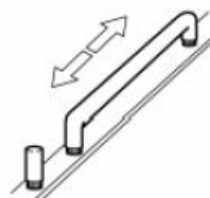

Attaching a hand grip



Prohibitions

**Do NOT support the patient's body weight only with the shoulder rests, hand grips or upper hand grip.**  
Tilting the tabletop could cause the patient to fall off the tabletop and be injured.



Instructions

**Completely fasten the compression band to the tabletop.**

If not fastened firmly, the compression band may come off or the lever may fall over, which could cause injury.



Instructions

**Gradually tighten the compression band while checking the patient's condition.**

Rapid tightening could cause bone fractures.



Prohibitions

**Do NOT support the patient's body weight only with the compression band.**

Tilting the tabletop could cause the patient to fall off the tabletop and be injured.



Instructions

**Take care when operating the imaging unit when the leg support is mounted, as the leg support is close to the column and the deck unit of the X-ray diagnostic table.**

The leg support may touch the column of the X-ray diagnostic table, which may injure the patient or damage the unit.



Prohibitions

**Be sure to use in a horizontal level when mounting the leg support to the unit.**

Do not mount the leg support in the vertical position or the Trendelenburg position, and do not tilt when mounting the leg support.

 CAUTION



**Do NOT use the monitor cart on a floor that is tilted more than 5°.**  
This could cause the monitor cart to fall over.

Prohibitions



**Do NOT move the monitor cart while its casters are locked.**  
This could cause the monitor cart to fall over.

Prohibitions



**Move the monitor cart by holding the handle, being careful about bumps and cables on the floor.**  
This could cause the monitor cart to fall over.

Instructions



**Watch out for the cable of the monitor cart.**  
If you catch the cable with your foot the monitor cart could fall over.

Instructions



**Do NOT apply force to the anti-scatter grid from above while it is pulled out.**  
Doing so could damage it.

Prohibitions



**To mount or remove the anti-scatter grid, move the tabletop all the way back and lift the hand guard.**  
If you do it without moving the tabletop all the way back, you may get your fingers caught between the tabletop and the grid.  
If you do it without lifting the hand guard, your fingers may be injured by the hand guard.

Instructions



**When holding the grid handle, take care not to allow your fingers to protrude from the grid.**  
Your fingers might get nipped between the unit and the grid.

Instructions

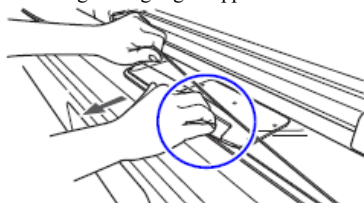

How to hold the handle –  
Good example



How to hold the handle –  
Bad example



**Make sure not to allow anyone to control the unit while you are mounting or demounting the anti-scatter grid.**  
If someone moves the tabletop, you may get the finger caught between the tabletop and the grid.

Instructions

## Digital Radiography Unit

 **WARNING**

  
Prohibitions

**Do NOT install any other software on the computer.**

The system may not run due to changes to the operating system or conflicting drivers. The warranty will be invalidated if any other software is installed.

 **CAUTION**

  
Instructions

**Observe the following precautions:**

- Do NOT attempt to alter any system software.  
It may cause the system to malfunction, resulting in loss of image.
- Do NOT attempt to alter any system hardware components.  
It may cause the system to malfunction, resulting in loss of image. Use of any hardware components (including mouse, keyboard, monitor, etc.) not provided by Shimadzu is strictly prohibited.
- Pay careful attention to other high frequency-generating equipment in the room. The PC cabinet should be as far as possible from any such device to prevent noise from affecting the image video signal.
- Do NOT disconnect the cables connected to this system.  
Otherwise the image may not be displayed, the data may be damaged and the system may fail to start up.
- Do NOT move any system component.  
If necessary, move it carefully to avoid damage.
- Do NOT apply any shocks to the system components.
- Do NOT place anything which may generate magnetic fields near the system components.
- Do NOT alter the system settings. Do NOT install any software to the system other than that provided by Shimadzu for this system.  
Otherwise, the system may fail to start up.

## Measurement Accuracy

 **WARNING**

  
Prohibitions

**Do NOT attempt to use the measurement function for purposes other than references for evaluation because precise image measurement is not possible.**

- English -

**Cautions on Data Loss**



**CAUTION**



**Instructions**

**Either archive (backup) important images or raw data in an external file system such as optical disks, or print it on film.**

If for some reason individual data is lost or corrupted, Shimadzu may adjust the system to prevent a reoccurrence of data loss; however, Shimadzu does not guarantee that the lost data can be restored.

Remember that the data stored on the system disk may be lost or corrupted at any time. Data loss may occur due to a decrease in performance of components (age deterioration) as well as a fault or malfunction of the equipment.

Create a hard copy of the image data on film without delay or save it on external media (CD-R or DVD-R) recommended by Shimadzu for safekeeping the important image data. Note that, however, the data recorded on external media may also be lost, and check the recorded data at regular intervals.

**CD-R/DVD-R**

Use the following CD-R or DVD-R disks recommended by Shimadzu for writing or reading of data. If any other disk is used, proper operation is not guaranteed.

Recommended CD-R disks:  
Disks, CD-R P/N: 562-27681-10 (10 per set)

Recommended DVD-R disks:  
Disks, DVD-R P/N: 562-27680-10 (10 per set)

**Cautions on Network Connections**

This equipment connects to the network for the following purposes.

- Obtains patient information, study information, and previous study images from an external equipment.
- Sends study images, study results information, dose information, and maintenance information of equipment to an external equipment.

Connect with the IPv4 network supporting 1000 Base-T/100 Base-T. Use the UTP LAN cable higher than Enhanced Category 5 (Cat 5e).

Intended Information Flow:

Destination	Typical information
Imager	Study image data
RIS server	Patient information, Study information, Study results information, Dose information
Storage server	Study image data
Remote maintenance server	Maintenance information of equipment

Risks of network failure:

Destination	Risks of network failure
Imager	Unable to print study images.
RIS server	Unable to obtain patient information and study information. Unable to send study results information and dose information.
Storage server	Unable to send study images.
Remote maintenance server	Unable to send maintenance information of equipment.



**CAUTION**



**Instructions**

**Shimadzu accepts no responsibility for any of the following items due to infection by malware (i.e. malicious software, including computer viruses and worms, which cause damage to the infected computer):**

- Loss, alteration, and leakage of data, including images, recorded on this equipment
- Accidents due to the malfunction of this equipment
- Infection of other equipment via this equipment and any damages incurred due to the infection
- Other issues including all events caused by malware infection

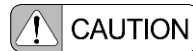

Instructions

**When using the networks described below, the customer must implement security measures to prevent infection by malware (i.e. malicious software, including computer viruses and worms, which causes damage to the infected computer).**

- Networks that lack security management
- Networks that may be subject to malware intrusion
- Networks that are connected to or have the ability to connect to the following devices
  - Devices that lack security management by the customer
  - Devices that can be used by persons unauthorized by the customer
  - Wireless communication devices

Examples of security management are as follows;

- NOT connecting to networks that lack security management
- NOT connecting to the internet
- Checking whether media (external storage media such as FDs, CDs and DVDs) are infected with malware before use.
- Avoiding actions that may result in malware infection
- NOT connecting to the network of another PC connectable to the internet.

Any viral infection or leakage of hospital information or patient information via internet connections is not covered under warranty.



Instructions

**It is strongly recommended that the user identify, analyze, evaluate, and control unacceptable risks resulting from a network connection.**

A connection of the equipment to a network might cause unacceptable risks that were not specified in advance for patients, operators or third parties.

Also, changing the network connection will invite new risks, which will also require additional analysis.

Changing the network connection includes the following:

- Changing the network configuration
- Adding on equipment to the network
- Removing equipment from the network
- Updating equipment connected to the network
- Upgrading equipment connected to the network

## Cautions on Cleaning and Disinfection



Instructions

**Be sure to turn the equipment power OFF before cleaning and disinfecting the equipment.**

Otherwise, a malfunction may occur in the equipment, or the equipment may operate in an unintended way.

Also, thoroughly ventilate the room before turning ON the power after disinfection work is complete.

- English -

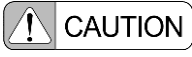

 **Be sure to clean and disinfect the equipment.**  
Cleaning and disinfection is very important to ensure that the equipment can be used hygienically and safely. Strictly follow the methods prescribed.

**Instructions**

 **Be sure to clean the equipment frequently and after each patient use.**  
While doing so, do NOT directly apply or spray any disinfectant, cleaner, or water onto the equipment. Wipe down all contact surfaces using a cloth moistened with an appropriate disinfectant or cleaner. Make sure the cloth is NOT too wet. If it is, liquid may enter into system electronics, causing failure or malfunction.

**Prohibitions**

 **Use disinfectants at a minimum.**  
Repeated disinfection over a long time may lead to discoloring and cracking on the equipment surface, and deterioration of rubber and plastic. If any abnormality is found on the equipment after disinfection, stop using the equipment immediately. Contact your Shimadzu service representative for repair.

**Instructions**

### Cautions on Emergency Stop

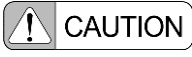



 **Press the STOP button to stop the equipment immediately in times of urgency.**  
Press the STOP button (red button) to stop the X-ray diagnostic table. The STOP button is provided on the front control panel of the X-ray diagnostic table and the panel.

**Instructions**

Moreover, press the power OFF button  to stop the X-ray generator. The power OFF button is provided on the hand switch holder.

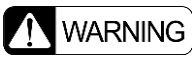
### Cautions Relating to Cellular Telephones



 **Do NOT bring any cellular telephones or related devices into the examination room with their power ON.**  
Such devices can exceed the EMC standard limitations, and under some conditions this can impair the proper functioning of the equipment. In the worst case, this can cause serious injuries or clinical errors.

**Prohibitions**

### Cautions on Electromagnetic Compatibility (EMC)



 **This equipment needs special precautions regarding EMC.**  
Install and use the equipment according to the EMC information provided in this instruction manual.

**Instructions**

 **Make sure that electromagnetic compatibility is obtained.**  
All peripheral devices must satisfy EMC standards regarding emission of electromagnetic energy and susceptibility to electromagnetic environment.  
Devices that do not satisfy these standards may disturb the correct functioning of the equipment. In the worst case, this can cause serious injuries or clinical errors.

**Instructions**

 **WARNING**

  
Prohibitions

**Do NOT use this equipment adjacent to, or stacked with, other equipment.**  
If adjacent or stacked use is necessary, check to be sure that this equipment works properly in the environment.

  
Prohibitions

**Do not use transducers, cables or other parts other than those specified or provided by Shimadzu.**  
The use of transducers, cables or other parts other than those specified or provided by Shimadzu could result in increased electromagnetic emissions or decreased electromagnetic immunity of this equipment and result in improper operation.

  
Prohibitions

**Portable RF communications equipment (including peripherals such as antenna cables and external antennas) should be used no closer than 30 cm (12 inches) to any part of the FLUOROspeed.**  
Otherwise, degradation of the performance of this equipment could result.

  
Prohibitions

**Portable RF communications equipment (including peripherals such as antenna cables and external antennas) using GSM 180, CDMA 1900, GSM 1900, DECT, LTE Band 1,3,4,25, UMTS should not be used no closer than 45 cm to any part of the FLUOROspeed, including cables specified by the manufacturer.**  
Otherwise, degradation of the performance of this equipment could result.

  
Prohibitions

**Portable RF communications equipment (including peripherals such as antenna cables and external antennas) using TETRA (TERrestrial Trunked RADio) should not be used no closer than 50 cm to any part of the FLUOROspeed, including cables specified by the manufacturer.**  
Otherwise, degradation of the performance of this equipment could result.

  
Prohibitions

**Portable RF communications equipment (including peripherals such as antenna cables and external antennas) using Bluetooth, Wireless LAN (2.4 GHz), RFID, LTE (Band7) should not be used no closer than 45 cm to any part of the FLUOROspeed, including cables specified by the manufacturer.**  
Otherwise, degradation of the performance of this equipment could result.

### Cautions When Irradiating Consecutive Pulse-shaped X-Ray Fluxes

 **WARNING**

  
Instructions

**Observe the following precautions when irradiating consecutive pulse X-rays:**

- Conducting studies involving irradiating consecutive pulse X-rays onto the region where an implantable pacemaker or defibrillator is implanted may cause these devices to malfunction.
- Refer to the "Important General Cautions," "Interactions," or other relevant sections in the accompanying documentation of the implantable pacemaker or defibrillator and take the prescribed measures before irradiating the implanted region of these devices with consecutive pulse X-rays.

Fluoroscopy or radiography performed by irradiating consecutive pulse X-rays (such as serial radiography with a few second intervals, pulsed fluoroscopy, digital angiography, DSA, or cineradiography) can adversely affect the CMOS circuit in implantable pacemakers and defibrillators. Such affects may cause oversensing in these devices that can temporarily inhibit pacing pulse output and result in an inappropriate heart rate.

- English -

## Performance Information For Medical Device

Refer to <https://www.shimadzu.com/med/> other than below.

Product name	Performance indicator	Rated value
X-ray tube assembly 0.2/0.8P38C-85	Nominal X-ray tube Voltage	Max. 125 kV
	Nominal focal spot value	0.2 / 0.8 mm
	Permanent filtration	1.0 mm Al/75 kV
X-ray tube assembly 0.3/0.8P18DK-85	Nominal X-ray tube Voltage	Max. 150 kV
	Nominal focal spot value	0.3 / 0.8 mm
	Permanent filtration	1.0 mm Al/75 kV
X-ray tube assembly 0.6/1.2P13DK-85	Nominal X-ray tube Voltage	Max. 150 kV
	Nominal focal spot value	0.6 / 1.2 mm
	Permanent filtration	1.0 mm Al/75 kV
X-ray tube assembly 0.6/1.2P33DK-85	Nominal X-ray tube Voltage	Max. 150 kV
	Nominal focal spot value	0.6 / 1.2 mm
	Permanent filtration	1.0 mm Al/75 kV
X-ray tube assembly 0.6/1.2P18DE-85	Nominal X-ray tube Voltage	Max. 150 kV
	Nominal focal spot value	0.6 / 1.2 mm
	Permanent filtration	1.0 mm Al/75 kV
X-ray tube assembly 0.6/1.2P38DE-85	Nominal X-ray tube Voltage	Max. 150 kV
	Nominal focal spot value	0.6 / 1.2 mm
	Permanent filtration	1.0 mm Al/75 kV
X-ray tube assembly 1/2P13DK-85	Nominal X-ray tube Voltage	Max. 150 kV
	Nominal focal spot value	1 / 2 mm
	Permanent filtration	1.0 mm Al/75 kV
X-ray tube assembly 1/2P33D-85	Nominal X-ray tube Voltage	Max. 150 kV
	Nominal focal spot value	1 / 2 mm
	Permanent filtration	1.0 mm Al/75 kV
X-ray tube assembly 1/2P18DK-85	Nominal X-ray tube Voltage	Max. 150 kV
	Nominal focal spot value	1 / 2 mm
	Permanent filtration	1.0 mm Al/75 kV
X-ray tube assembly 1/2P38D-85	Nominal X-ray tube Voltage	Max. 150 kV
	Nominal focal spot value	1 / 2 mm
	Permanent filtration	1.0 mm Al/75 kV
X-ray tube assembly 0.3/0.8P323DK-85	Nominal X-ray tube Voltage	Max. 150 kV
	Nominal focal spot value	0.3 / 0.8 mm
	Permanent filtration	1.0 mm Al/75 kV
X-ray tube assembly 0.6/1.2P123DK-85	Nominal X-ray tube Voltage	Max. 150 kV
	Nominal focal spot value	0.6 / 1.2 mm
	Permanent filtration	1.0 mm Al/75 kV
X-ray tube assembly 0.6/1.2P323DK-85	Nominal X-ray tube Voltage	Max. 150 kV
	Nominal focal spot value	0.6 / 1.2 mm
	Permanent filtration	1.0 mm Al/75 kV
X-ray tube assembly 0.8P323DK-85	Nominal X-ray tube Voltage	Max. 150 kV
	Nominal focal spot value	0.8 mm
	Permanent filtration	1.0 mm Al/75 kV
X-ray tube assembly 0.2/0.8P39CK-85	Nominal X-ray tube Voltage	Max. 125 kV
	Nominal focal spot value	0.2 / 0.8 mm
	Permanent filtration	1.0 mm Al/75 kV
X-ray tube assembly 0.3/0.8P324DK-85	Nominal X-ray tube Voltage	Max. 150 kV
	Nominal focal spot value	0.3 / 0.8 mm
	Permanent filtration	1.0 mm Al/75 kV
X-ray tube assembly 0.6/1.2P324DK-85	Nominal X-ray tube Voltage	Max. 150 kV
	Nominal focal spot value	0.6 / 1.2 mm
	Permanent filtration	1.0 mm Al/75 kV

Product name	Performance indicator	Rated value
X-ray tube assembly 0.6/1.2P164DK-85	Nominal X-ray tube Voltage	Max. 150 kV
	Nominal focal spot value	0.6 / 1.2 mm
	Permanent filtration	1.0 mm Al/75 kV
X-ray tube assembly 0.6/1.2P364DK-85	Nominal X-ray tube Voltage	Max. 150 kV
	Nominal focal spot value	0.6 / 1.2 mm
	Permanent filtration	1.0 mm Al/75 kV
X-ray tube assembly 0.6/1.2P324DK-125	Nominal X-ray tube Voltage	Max. 150 kV
	Nominal focal spot value	0.6 / 1.2 mm
	Permanent filtration	1.0 mm Al/75 kV
X-ray tube assembly 0.6/1.2P364DK-125	Nominal X-ray tube Voltage	Max. 150 kV
	Nominal focal spot value	0.6 / 1.2 mm
	Permanent filtration	1.0 mm Al/75 kV
X-ray tube assembly 0.8P324DK-85	Nominal X-ray tube Voltage	Max. 150 kV
	Nominal focal spot value	0.8 mm
	Permanent filtration	1.0 mm Al/75 kV
X-ray tube assembly 0.4/0.7JG326D-265	Nominal X-ray tube Voltage	Max. 150 kV
	Nominal focal spot value	0.4 / 0.7 mm
	Permanent filtration	1.1 mm Al/75kV
X-ray tube assembly 0.7/1.2JG326D-265	Nominal X-ray tube Voltage	Max. 150 kV
	Nominal focal spot value	0.7 / 1.2 mm
	Permanent filtration	1.1 mm Al/75kV
X-ray tube assembly 1.2U161CS-31	Nominal X-ray tube Voltage	Max. 125 kV
	Nominal focal spot value	1.2 mm
	Permanent filtration	1.9 mm Al/75kV
X-ray tube assembly 0.7U161CS-36	Nominal X-ray tube Voltage	Max. 125 kV
	Nominal focal spot value	0.7 mm
	Permanent filtration	2.0 mm Al/75kV
X-ray tube assembly 0.7U163CS-36	Nominal X-ray tube Voltage	Max. 125 kV
	Nominal focal spot value	0.7 mm
	Permanent filtration	2.0 mm Al/75kV
X-ray tube assembly 0.7/1.3U163C-36	Nominal X-ray tube Voltage	Max. 133 kV
	Nominal focal spot value	0.7 / 1.3 mm
	Permanent filtration	2.0 mm Al/75kV
X-ray tube assembly 0.6/1J327C-280	Nominal X-ray tube Voltage	Max. 125 kV
	Nominal focal spot value	0.6 / 1 mm
	Permanent filtration	1.5 mm Al/75kV
X-ray tube assembly 0.6/1J317C-282	Nominal X-ray tube Voltage	Max. 125 kV
	Nominal focal spot value	0.6 / 1 mm
	Permanent filtration	1.5 mm Al/75kV
X-ray tube assembly 0.6/1.2P326D-150	Nominal X-ray tube Voltage	Max. 150 kV
	Nominal focal spot value	0.6 / 1.2mm
	Permanent filtration	1.0 mm Al/75kV
X-ray tube assembly 0.6/1.2P366D-150	Nominal X-ray tube Voltage	Max. 150 kV
	Nominal focal spot value	0.6 / 1.2mm
	Permanent filtration	1.0 mm Al/75kV

- English -

## Revision History

Revision	Date	Description
-	2019-12-11	Newly published
A	2023-04	Product identifications and product performance were added.
B	2025-03-19	Added products to product identifications and product performance. Modifying Regulatory Information.
C	2025-04-14	Modified "Safety, Environmental, and Regulatory Information For Medical Device" <ul style="list-style-type: none"> <li>- Modified "General"</li> <li>- Added "Digital Angiography System Trinias"</li> <li>- Added "RADspeed Pro"</li> </ul>
D	2026-05-20	Added "X-RAY TV SYSTEM SONIALVISION G4" Added "X-RAY R/F SYSTEM FLUOROSpeed"
E	2026-06-01	Updated Index. Added "Mobile X-ray System Mobirex i9" Added "SURGICAL MOBILE C-ARM IMAGING SYSTEM OPESCOPE ACTENO (I.I. Type)" Added "SURGICAL MOBILE C-ARM IMAGING SYSTEM OPESCOPE ACTENO (FD Type)"

# 文書承認履歴

文書の承認履歴を以下に記述します。

文書番号: M516-C007E

文書名称: Safety, Environmental, and Regulatory Information For Medical Device

区分	ID	氏名	日時
作成	000046	山下 登	2026/06/04 08:53:34
検討1	501018	佐久間 淳	2026/06/04 09:03:49
承認1	001471	小林 慎一	2026/06/04 09:13:50

## 制定・改訂理由

制定・改訂理由:

Mobirex i9、ACTENO (I.I. Type)、ACTENO (FD Type)の内容を反映しました

制定・改訂理由詳細: